

# Introduction to Power Electronics

Valery Vodovozov

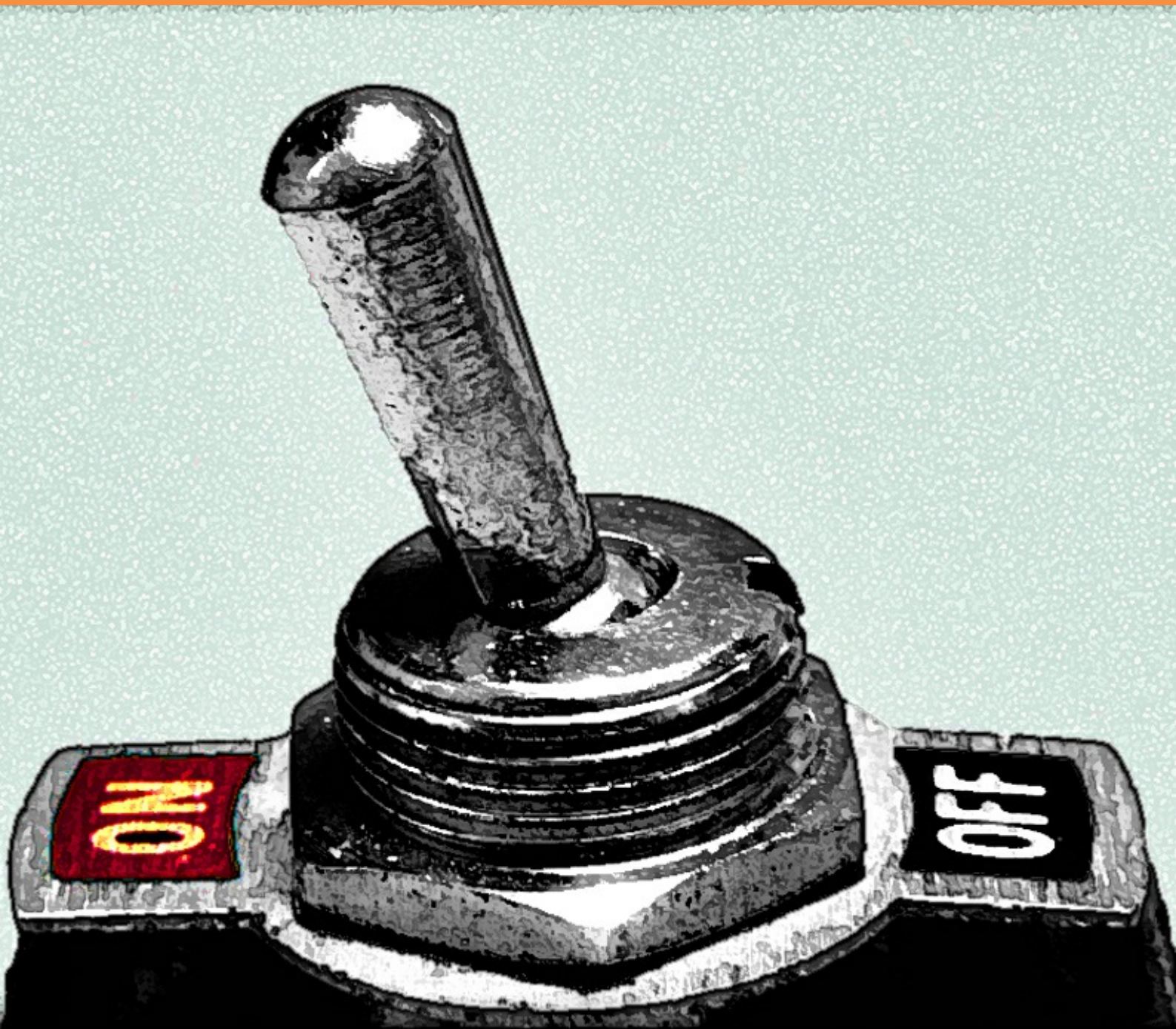

VALERY VODOVOZOV

---

# INTRODUCTION TO POWER ELECTRONICS

Introduction to Power Electronics

1<sup>st</sup> edition

© 2019 Valery Vodovozov & [bookboon.com](http://bookboon.com)

ISBN 978-87-7681-625-4

# CONTENTS

	<b>Preface</b>	<b>6</b>
	<b>Designations</b>	<b>7</b>
	<b>Introduction</b>	<b>9</b>
<b>1</b>	<b>Power Electronic Converters</b>	<b>17</b>
1.1	AC/DC Converters – Rectifiers	18
1.2	DC/AC Converters – Inverters	31
1.3	AC/AC Converters – Changers	48
1.4	DC/DC Converters – Choppers	61



www.sylvania.com

We do not reinvent  
the wheel we reinvent  
light.

Fascinating lighting offers an infinite spectrum of possibilities: Innovative technologies and new markets provide both opportunities and challenges. An environment in which your expertise is in high demand. Enjoy the supportive working atmosphere within our global group and benefit from international career paths. Implement sustainable ideas in close cooperation with other specialists and contribute to influencing our future. Come and join us in reinventing light every day.

Light is OSRAM

**OSRAM  
SYLVANIA** 

<b>2</b>	<b>Power Electronic Controls</b>	<b>78</b>
2.1	Phase Modulation	79
2.2	Block Modulation	91
2.3	Pulse-Width Modulation	104
2.4	Space Vector Modulation	114
	<b>Index</b>	<b>120</b>

# PREFACE

Power Electronics is the technology associated with efficient conversion, control and conditioning of electric power from its available input into the desired electrical output form. The field of the book is concerned of electrical power processing using electronic devices the key component of which is a switching power converter.

Power electronics has found an important place in modern technology being a core of power and energy control. Almost all the new electrical and electromechanical equipment contain power circuits. The power levels encountered in this field range from less than one watt in supplies for the battery-operated portable equipment to tens, hundreds, or thousands of watts in power units of office equipment, kilowatts to megawatts in variable-speed motor drives, approaching megawatts in the rectifiers and inverters that interface the local transmission lines with the high power systems.

The goal of this work is to introduce students and working engineers involved in power and energy conversion to the basics of this discipline. The emphasis is on the day-to-day electronic products. The course covers the features and functions of rectifiers, inverters, ac and dc converters. It provides a wealth of technical information and contributes to learning the design of circuits and equipment based on electronic components.

The book is recommended as the introductory manual to power electronics. It can be used as a textbook for undergraduate students in electrical or systems engineering, or as a reference book for graduate students and engineers who are interested and involved in operation, project management, design, and analysis of power electronic equipment. The background of the course is “Introduction to Electronic Engineering”.

It is obvious that a wide coverage, such as presented in this book, may lead to any kind of imperfections. Thus, your commentary and criticisms are appreciated: [valery.vodovozov@ttu.ee](mailto:valery.vodovozov@ttu.ee).

*Author*



# DESIGNATIONS

## Symbols

<b>C</b>	capacitor	$q$	duty cycle
<b>L</b>	inductor, choke	$R$	resistance
<b>M</b>	motor	$T$	period, time constant
<b>R</b>	resistor	$t$	time
<b>VD</b>	diode	$U$	voltage
<b>VS</b>	thyristor	$\alpha$	firing angle
<b>VT</b>	transistor	$\beta$	angle in advance
$C$	capacitance	$\gamma$	overlap angle
$\cos \varphi$	power factor	$\delta$	error
$f$	frequency	$\eta$	efficiency
$I$	current	$\theta$	electrical angle
$k$	factor, coefficient	$\pi$	circle ratio (3,14159)
$L$	inductance	$\varphi$	angle
$L1,2,3$	three-phase frame	$\omega$	angular frequency
$P$	power		

## Abbreviations

A	Ampere	M	Mega = $10^6$ (prefix)
ac	alternating current	m	milli = $10^{-3}$ (prefix)
BJT	bipolar junction transistor	MCT	MOS-controlled thyristor
CSI	current source inverter	MOS	metal-oxide semiconductor
dc	direct current	n	nano = $10^{-9}$ (prefix)
EMC	electromagnetic compatibility	p	pico = $10^{-12}$ (prefix)
EMF	electromotive force	PWM	pulse-width modulation
F	Farad	rms	root mean square
FET	field-effect transistor	s	second
G	Giga = $10^9$ (prefix)	SCR	silicon controlled rectifier
GTO	gate turn-off thyristor	SVM	space vector modulation
H	Henry	V	Volt
Hz	Hertz	VDC	dc Volt
IGBT	insulated gate bipolar transistor	VSI	voltage source inverter
JFET	junction FET	W	Watt
k	kilo = $10^3$ (prefix)	ZCS	zero-current switch

ZVS	zero-voltage switch
$\mu$	micro = $10^{-6}$ (prefix)
$\Omega$	Ohm



# INTRODUCTION

*Power electronics* makes up a large part of engineering and has close connections with many areas of physics, chemistry, and mechanics. It establishes a rapidly expanding field in electrical engineering and a scope of its technology covers a wide spectrum. Power applications with electronic converters do a lot of difficult work for us. Optimists envision power electronics doing more and more things for the population. Electronic appliances contribute to a healthier and more comfortable live the world over. Thanks to advances in science and related technology, many people no longer have to spend much time working for the bare necessities of life. Whatever it is that we really want to do, power electronics helps us to do it better.

**Historical background.** In terms of world history, power electronics is a young science. The earliest studied in the field of power electronics date back to the end of the 19<sup>th</sup> century. In 1882, French physicist J. Jasmin discovered a phenomenon of semiconductance and proposed this effect to be used for ac rectifying. In 1892, German researcher L. Arons invented the first mercury arc vacuum valve. P.C. Hewitt developed the first arc valve in 1901 in USA and a year later, he patented the mercury rectifier. In 1906, J.A. Fleming invented the first vacuum diode, American electrician G.W. Pickard proposed the silicon valve, and L. Forest patented the vacuum tube. The development of electronic amplifiers started with this invention and in 1907, a vacuum triode was built by L. Forest. Later, based on the same principles different kinds of electronic devices were worked out. A key to the technology was the invention of the feedback amplifier by H.S. Black in 1927. In 1921, F.W. Meyer from Germany first formulated the main principles and trends of power electronics.

In the first half of the 20<sup>th</sup> century, electronic equipment was mainly based on vacuum tubes, such as gas-discharge valves, thyratrons, mercury arc rectifiers, and ignitrons. Until the end of the 1920<sup>th</sup>, vacuum diodes (kenotrones) were the main electronic devices. In the 1930<sup>th</sup>, they were replaced by mercury equipment. The majority of valves were arranged as coaxial closed cylinders round the cathode. Valves that were more complex contained several gridded electrodes between the cathode and anode. The vacuum tube had a set of disadvantages. First, it had an internal power heater. Second, its life was limited by a few thousand hours before its filament burns out. Third, it was bulky. Fourth, it gave off heat that raised the internal temperature of the electronics equipment. Because of vacuum tube technology, the first electronic devices were very expensive and dissipated a great deal of power.

The first electronics revolution began in 1948 with the invention of the transistor by American scientists J. Bardeen, W.H. Brattain, and W.B. Shockley from “Bell Labs”. Later they were awarded a Nobel Prize for this invention. Most of today’s advanced electronic

technologies are traceable to that invention. From 1952, “General Electric” manufactured the first germanium diodes. In 1954, G. Teal at “Texas Instruments” produced a silicon transistor, which gained wide commercial acceptance because of the increased temperature performance and reliability. During the mid 1950<sup>th</sup> through to the early 1960<sup>th</sup>, electronic circuit designs began to migrate from vacuum tubes to transistors, thereby opening up many new possibilities in research and development projects.

Before the 1960<sup>th</sup>, semiconductor engineering was regarded as part of low-current and low-voltage electronic engineering. The currents used in solid-state devices were below one ampere and voltages only a few tens of volts. The period of power semiconductors began in 1956, when the silicon-based thyristors were invented by a research team led by J. Moll from “General Electric”. Development of a commercial thyristor ran the second electronics revolution. Based on these inventions, several generations of power semiconductor devices and conversion techniques have been worked out.

The time of 1956–1975 can be considered as the era of the first generation power devices. During the years of second-generation power devices from 1975 till 1990, the metal-oxide semiconductor field-effect transistors, bipolar *nnp* and *pnp* transistors, junction transistors, and gate turn-off thyristors were developed. Later the microprocessors, specified integral circuits, and power integral circuits were produced. In the 1990<sup>th</sup>, the insulated gate bipolar transistor was established as the power switch of the third generation. A new trend in electronics brought intelligent power devices and modules.

Today, power electronics is a rapidly expanding field in electrical engineering and a scope of the technology covers a wide spectrum of electronic *converters*. Different kinds of power supplies are used everywhere in normal daily routines both at home, office and industry. This is due to the progress in electronic components and equipment development that has been achieved in the last few decades. Electronic and electrical apparatus are everywhere, and all these devices need electrical power to work. Most of electronic supplies are switching semiconductor converters thanks to the efficiency, size, capability to operate at various current and voltage levels, control features and price compared to the linear power supply.

**Power electronic system.** Any technical system is an assembly of components that are connected together to form a functioning machine or an operational procedure. A *power electronic system* assembles next general building blocks:

- AC/DC converters – rectifiers that transform ac to dc with adjustment of voltage and current
- DC/AC converters – inverters that produce ac of controllable magnitude and frequency, particularly with galvanic isolation via a transformer

- AC/AC converters – ac frequency, phase, magnitude, and power converters, both without an with an intermediary dc link
- DC/DC converters – linear regulators and switching choppers

In turn, each block consists of the primary electronic elements that are: resistors, capacitors, transformers, inductors (choke coils), frames, etc., and basic classes of semiconductor devices:

- diodes, including Zener, optoelectronic and Schottky diodes, and diacs
- thyristors, particularly silicon-controlled rectifiers (SCR), triacs, gate turn-off (GTO), and MOS-controlled thyristors (MCT)
- transistors, such as bipolar junction (BJT), field-effect (FET), and insulated gate bipolar (IGBT) transistors

Diodes, thyristors and transistors are the essential components of the power electronic applications. Today, the single wafer diodes are able to block more than 9 kV over a wide temperature range. At the same time, thyristors withstand more than 10 kV. These devices conduct up to 5 kA. The levels of 6 kV and 0,6 kA are approachable by power transistors. A comparative diagram of power ratings and switching speeds of the controlled semiconductor electronic devices is given in Fig. 1.



Discover the truth at [www.deloitte.ca/careers](http://www.deloitte.ca/careers)

**Deloitte.**

© Deloitte & Touche LLP and affiliated entities.

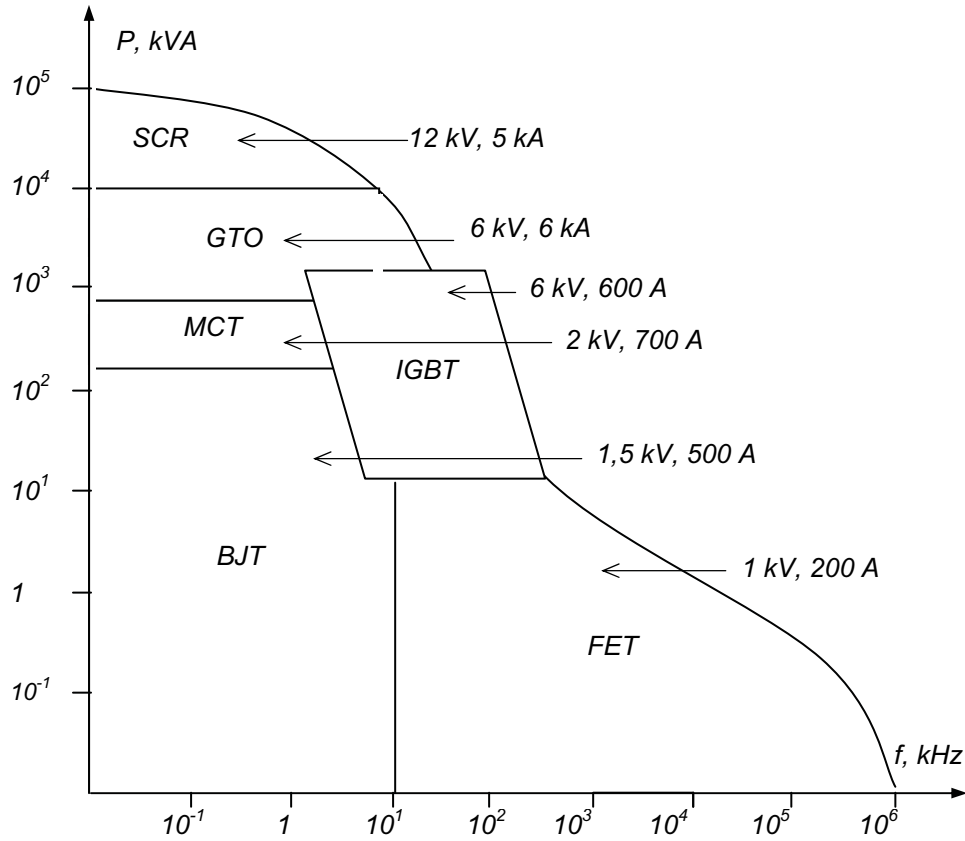

Fig.1

**Power diodes.** *Diodes* (Fig. 2, a) are the main building blocks of rectifiers, rectifier sections of ac and dc converters, their freewheeling paths, and multiple control electronic units. That is why a diode is the most commonly used electronic device in the modern power electronic systems.

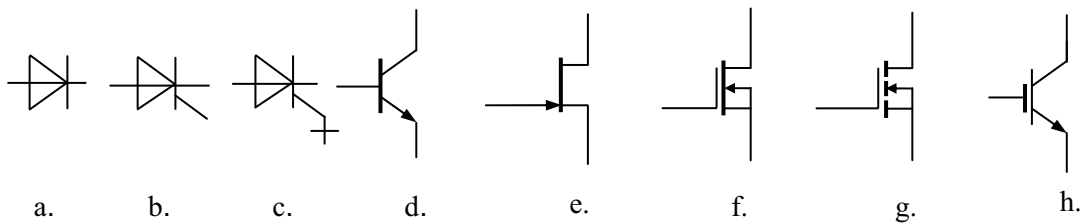

Fig.2

The rectifier diode has a smaller voltage drop in the forward-bias state as compared to the operating voltages and very small leakage current in the reverse-bias state. The forward bias characteristic of the power diode is approximately linear, which means that the voltage drop is proportional to the ohmic resistance and current. The maximum current in the forward bias depends on the *pn* junction area. Today, the rated currents of power diodes approach kiloamperes.

At turn on, the diode can be considered as an ideal switch because it opens rapidly compared to transients in the circuit. In most of circuits, the leakage current does not have a significant effect on the circuit and thus the diode can be considered as a switch.

In the case of reverse-biased voltage, only a small leakage current flows through the diode. This current is independent of the reverse voltage until the breakdown voltage is reached. After that, the diode voltage remains essentially constant while the current increases dramatically. Only the resistance of the external circuit limits the maximum value of the current. Simultaneous large current and large voltage in the breakdown operation leads to excessive power dissipation that could quickly destroy the diode. Therefore, the breakdown operation of the diode must be avoided.

A bi-directional diode that can be triggered into conduction by reaching a specific voltage value is called a *diac*.

**Power thyristors.** Rectifier *thyristors* (Fig. 2, *b*) known as silicon-controlled rectifiers (SCR) are commonly used in adjustable rectifier circuits, especially in high power units up to 100 MVA. Their frequency capabilities are not high, being lower than 10 kHz.

If positive voltage is applied without gate current, the thyristor constitutes the state of forward blocking. A low-power pulse of gate current switches the thyristor to the on state. The output characteristic of a conducting thyristor in the forward bias is very similar to the same curve of the diode with a small leakage current. Thus, the thyristor assumes very low resistance in the forward direction. Once turned on, the thyristor remains in this state after the end of the gate pulse while its current is higher than the holding level. If the current drops below the holding value, the device switches back to the non-conducting region. Switching off by gate pulse is impossible. Therefore, using the same arguments as for diodes, the thyristor can be represented by the idealized switch.

When a thyristor is supplying by ac, the moment of a thyristor opening should be adjusted by shifting the control pulse relative to the starting point of the positive alternation of anode voltage. This delay is called the *firing angle*  $\alpha$ .

The output characteristic of SCR in the reverse bias is very similar to the same curve of the diode with a small leakage current. With negative voltage between anode and cathode, this corresponds to the reverse blocking state. If the maximum reverse voltage exceeds the permissible value, the leakage current rises rapidly, as with diodes, leading to breakdown and thermal destruction of the thyristor.

A *triac* (bi-directional thyristor) is identified as a three-electrode semiconductor device that switches conduction on and off during each alternation. It is the equivalent of the two reverse-parallel-connected thyristors with the common gate.

Besides the rectifier thyristors, the *gate turn-off thyristors* (GTO) are produced (Fig. 2, c). These devices have two adjustable operations: they can be turned on or off by the current gate pulses. The GTO thyristor turns on similarly to the SCR thyristors, i.e. after the current pulse will be applied to the gate electrode. To turn it off, a powerful negative current control pulse must be applied to the gate electrode.

A switching frequency range of a GTO thyristor is a few hundred hertz to tens kilohertz. Their on-state voltage (2–3 V) is higher than that of SCR. Because of their capability of handling large voltages (up to 5 kV) and large currents (up to a few kiloamperes at 10 MVA), the GTO thyristors are more convenient to use than the SCR thyristors in applications where high price and high power are allowed.

The *MOS-controlled thyristor* (MCT) has many of the properties of a GTO thyristor, including a low voltage drop at high currents. Nevertheless, it is a voltage-controlled device. Here, turning on is controlled by applying a positive voltage signal to the gate, and turning off



**WHY  
WAIT FOR  
PROGRESS?**

**DARE TO DISCOVER**

Discovery means many different things at Schlumberger. But it's the spirit that unites every single one of us. It doesn't matter whether they join our business, engineering or technology teams, our trainees push boundaries, break new ground and deliver the exceptional. If that excites you, then we want to hear from you.

**Dare to discover.**  
[careers.slb.com/recentgraduates](https://careers.slb.com/recentgraduates)

**Schlumberger**



by a negative voltage. Therefore, the MCT has two principle advantages over the GTO, including much simpler drive requirements (voltage instead of current) and faster switching speeds (few microseconds). Its available voltage rating is 1,5–3 kV and currents of hundreds amperes. The last ones are less than those of GTO.

**Power transistors.** The operation of a *bipolar junction transistor* (BJT) (Fig. 2, *d*) is described by the output characteristic that has three distinct operating regions. When a BJT is used as an amplifier, the transistor operates in the active region. Another area of operation is the breakdown region. The transistor should never operate in this region because it very likely will be destroyed. The rising part of the output curve, where voltage is between 0 and approximately 1 V is called the saturation region. Here, the resistance of the device is very low and it is opened fully. When it is used in digital and switching circuits, the transistor commonly operates in this region during the long time.

The main advantages of a power BJT are as follows: high power handling capabilities, up to 100 kVA, 1500 V, 500 A and sufficiently low forward conduction voltage drop. The main disadvantages of BJT are: relatively slow switching times and inferior safe operating area. Thus, the overvoltage protection and complex base controllers are required.

In contrast to a BJT, *junction field-effect transistors* (JFET) (Fig. 2, *e*) have some advantages. Due to voltage adjustment, their control circuit is simple and their control power is low. Because a JFET is an electron-majority carrier device, its switching transient speed grows essentially. For the same reason, its on-state resistance has a positive temperature coefficient that is the resistance rises with the temperature rise. Accordantly, the current falls with the load and the parallel connection of such devices is not the problem. Thanks to the absence of the second breakdown, the safe operating area is large; therefore, the overvoltage protection is not needed.

Nevertheless, due to the high resistance to the current flow, the efficiency of a JFET is not high when a number of transistors are connected in parallel and the additional losses between the source and the drain complicate the control processes.

MOSFET (Fig. 2, *f*, *g*) is another voltage-controlled *metal-oxide semiconductor field-effect transistor*. Unlike a JFET, their metallic gates are electrically insulated from the channel; therefore, the input resistance is even higher than that of a JFET. The advantages of the MOSFETs are as follows: high switching capability that is the operational frequencies reach gigahertz; simple protection circuits and voltage control; normally off device when the enhancement mode is used; and easy paralleling to increase the current values.



The drawbacks of the MOSFET are as follows: relatively low power handling capabilities, less than 10 kVA, 1000 V, and 200 A; and relatively high (more than 2 V) forward voltage drop, which results in higher losses than in BJT.

Both BJT and MOSFET have the technical parameters and characteristics that complement each other. BJTs have lower conduction losses in the on state, especially at larger blocking voltages, but they have longer switching times. MOSFETs are much faster, but their on-state conduction losses are higher. Therefore, attempts were made to combine these two types of transistors on the same silicon wafer to achieve better technical features. These investigations resulted in the development of the *insulated gate bipolar transistor* (IGBT), which is becoming the device of choice in most of new power applications (Fig. 2, h).

IGBTs have the highest power capabilities up to 1700 kVA, 2000 V, 800 A. Because of the less resistance than the MOSFET, the heating losses of the IGBT are lower too. Their forward voltage drop is 2...3 V, that is higher than that of a bipolar transistor but lower than the MOSFET has. Due to the negative temperature coefficient, when a temperature is raised, the power and heating decrease therefore the device withstands the overloading and operates in parallel well. The reliability of the IGBTs is higher than that of the FETs thanks to the absence of a secondary breakdown. They have relatively simple voltage controlled gate driver and low gate current. Unfortunately, IGBTs are not suitable for high frequency supply sources.

# 1 POWER ELECTRONIC CONVERTERS

Interaction between the utility supply and the load depends on the topology of the power system, which converts the line feed into the load power. The availability of excellent fast commutation devices and advancements in digital technology have driven a rapid power converter development. The four main classes of power electronic converters are depicted in Fig. 3. They are:

- AC/DC converters called rectifiers that convert input ac voltage  $U_s$  to dc with adjustment of output voltage  $U_d$  and current  $I_d$  (Fig. 3, a)
- DC/AC converters called inverters that produce output ac voltage  $U_s$  of controllable magnitude and frequency from input dc voltage  $U_d$  (Fig. 3, b)
- AC/AC converters called frequency converters and changers that establish ac frequency, phase, magnitude, and shape (Fig. 3, c)
- DC/DC converters called choppers that change dc voltage and current levels using the switching mode of semiconductor devices (Fig. 3, d)

SIMPLY CLEVER

ŠKODA



**We will turn your CV into an opportunity of a lifetime**



Do you like cars? Would you like to be a part of a successful brand? We will appreciate and reward both your enthusiasm and talent. Send us your CV. You will be surprised where it can take you.

Send us your CV on  
[www.employerforlife.com](http://www.employerforlife.com)



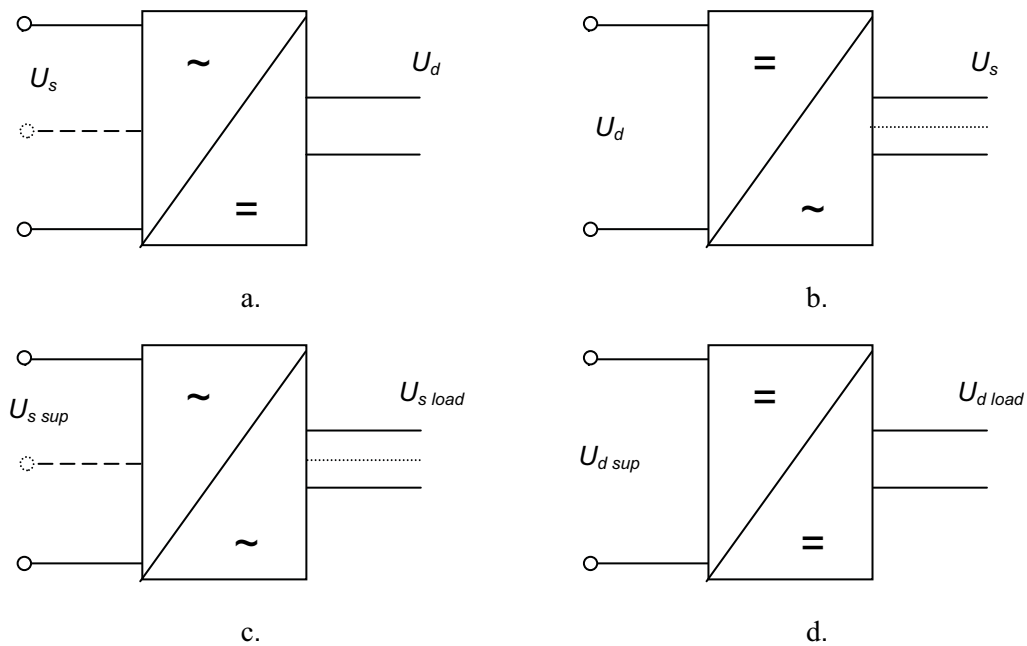

Fig.3

## 1.1 AC/DC CONVERTERS – RECTIFIERS

**Rectification.** *AC/DC converters* serve as *rectifiers*. They convert ac to dc in a number of industrial, domestic, agricultural, and other applications. Rectifiers are used as stand-alone units feeding single and multiple dc loads and as input stages of ac systems because of their virtually unlimited output power and fine controllability. Their speed of response is usually adequate to handle electromechanical transients occurring in motor drives and power suppliers.

*AC/DC line-commutated converters* or, as they also called, converters with natural commutation or *passive rectifiers*, are the most usual choice for applications, where a single-phase and three-phase supply is available. This is due to simplicity of the circuits requiring a minimum number of active and passive components. Thyristors are the main line-commutated power switches. The term “line-commutated” describes the type of commutation, i.e. the transfer of current from one conducting element to the next, as a function of the mains voltage. To turn on a thyristor, an injection of a current pulse into its gate is required.

In low-power applications, vehicle, medicine, and household devices, where there is no ac supply or where reactive current and harmonics caused by a line commutation would be unreachable, it is accepted to employ *forced commutated converters* having a more complex circuitry and sometimes involving higher losses. A special situation exists also with dc and ac loads, where the response of a line-commutated converter may be insufficient to cope

with the stringent dynamic and energy efficiency demands and where an additional converter supplied by a dc link and operated with a higher switching frequency is necessary. For these purposes active rectifiers are developed.

The basic rectifier topologies are given in the *circuit diagrams* of Fig. 4 where the load is presented by the dc motors. The systems built on diodes are called *uncontrolled rectifiers*, and those built on thyristors and transistors are known as *controlled rectifiers* because their dc output can be changed. The rectification processes are quite varied; accordingly, there are different types of rectifying circuits:

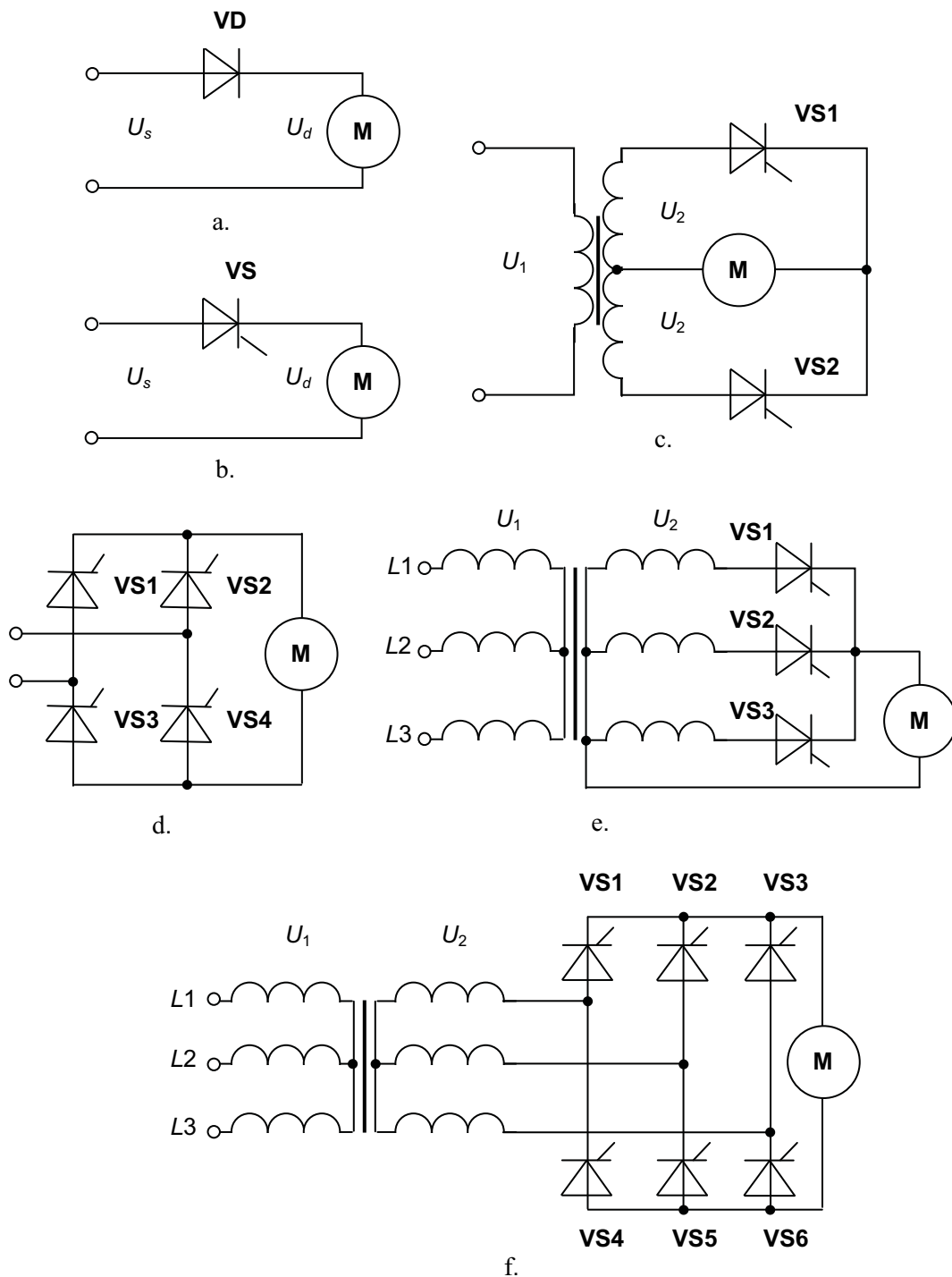

Fig.4

- midpoint (M) and bridge (B) rectifiers
- single-phase (M1, M2, B2) and three-phase (M3, B6) rectifiers
- half-wave (1 pulse per supply period) and full-wave (2, 3, 6 pulses) rectifiers

**Rectifier data.** Rectifiers differ by the shape of dc signal, ripples, and efficiency that depends on rms, average, and amplitude values of voltage, current, and power. Their power range is very wide, from milliwatts to megawatts. Low-power devices operate usually from a single-phase supply while high-power rectifiers are mainly used in a three-phase configuration. In the table below, the main data of different non-controlled rectifier circuits with a resistive load are given.

Circuit type	$k_U = \frac{U_s}{U_d}$	$k_I = \frac{I_s}{I_d}$	$k_P = \frac{P_s}{P_d}$	$\cos \varphi = \frac{P_d}{P_s}$	$k_R = \frac{U_R}{U_d}$	$k_F = \frac{I_F}{I_d}$	$k_r = \frac{U_r}{2U_d}$
M1	2,22	1,57	3,10	0,29	3,14	1,00	1,57
M2	1,11	0,71	1,58	0,64	3,14	0,50	0,78
B2	1,11	1,00	1,11	0,90	1,57	0,50	0,78
M3	0,85	0,58	1,58	0,64	2,09	0,33	0,25
B6	0,42	0,82	1,05	0,95	1,05	0,33	0,06

The apparent rms power  $P_s$ , phase voltage  $U_s$ , and current  $I_s$  supply the rectifier directly, through chokes, or via a transformer. In the last case  $U_s = U_2$ ,  $P_s = P_2$ . The average rectified load power  $P_d$ , voltage  $U_d$ , and current  $I_d$  are the pulsating dc signals with 1, 2, 3, or 6 pulses per supply period  $T$ . Parameters  $k_U$ ,  $k_I$ ,  $k_P$ ,  $k_R$ , and  $k_F$  are called voltage, smoothed current, power, reverse, and forward circuit factors.

The *ripple factor*  $k_r$  of the output waveform is usually determined by the rectified peak-to-peak ripple voltage swing  $U_r$  (see Fig. 5 below). The peak inverse voltage  $U_R$  and forward current  $I_F$  of each rectifier device depends on the circuit type. The *power factor* of a rectifier defines the ratio of the real average active power  $P_d$  to the apparent power  $P_s$ , which is the product of the rms voltage and the rms current, therefore  $\varphi$  is a *phase displacement angle* of current relative to voltage. For the given voltage, the rms current drawn is

$$I_s = \frac{P_d}{U_s \cos \varphi}$$

This shows that the power factor and the current are inversely proportional values. The current flows through the utility distribution and transmission lines, transformers and so on exciting the losses in their resistances. If the losses grow, possibly to the point of overloading, harmonic currents may cause resonance conditions in transmission lines. The supply voltage waveform will also be distorted, adversely affecting other linear loads, if a significant portion of the load supplied by the consumer absorbs power by mean of distorted currents. This is the reason why consumers prefer unity power factor that draws power at the minimum value of the rms current.

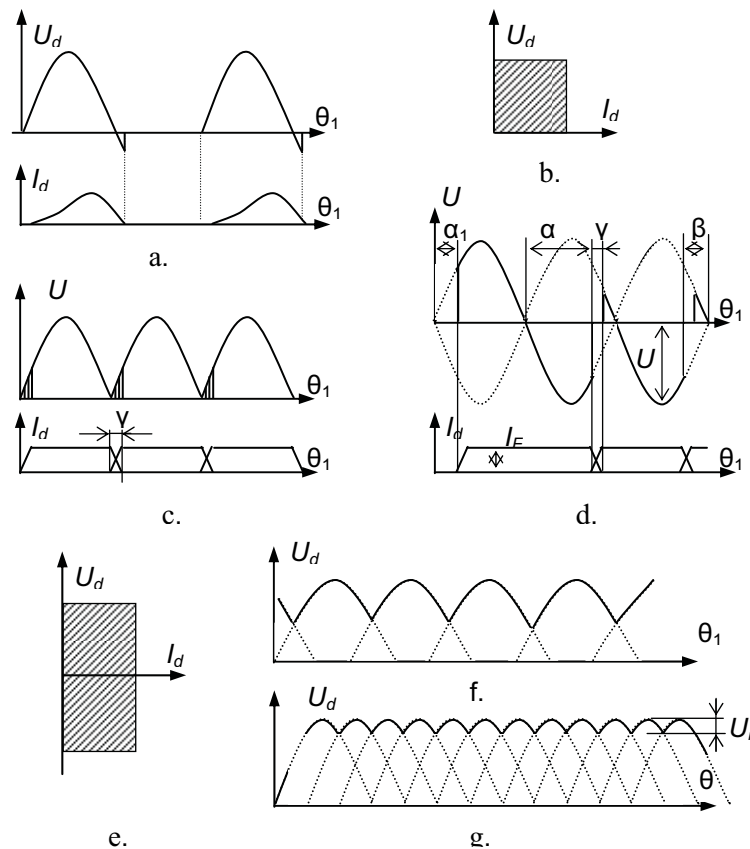

Fig. 5

**Single-phase rectifiers.** At power levels below a few kilowatts, for example in residential applications, the loads are supplied by a single-phase supply source. Commonly used simple half-wave *single-phase rectifier* circuits (M1) are represented in Fig. 4, *a, b*. The resulting output *voltage* and *current* waveforms of the half-wave diode rectifier are shown in Fig. 5, *a*. Here

$$\theta_1 = \omega_1 t$$

$$\omega_1 = 2\pi f_1,$$

where  $\omega_1$  is the angular frequency,  $f_1$  is the frequency of the supply voltage, and  $t$  is time. During the positive alternation of the ac sinusoidal wave, the anode of the diode **VD** is positive and the cathode is negative, the diode conducts since it is forward-biased. The positive alternation of the ac will then appear across the load motor **M**. During the negative alternation of ac cycle, the anode becomes negative while the cathode is positive. The diode is reverse-biased by this voltage and practically no current will flow through the load. Therefore, no voltage appears across the load. Such type of the converter is called a *half-wave rectifier* because the negative half cycles have been clipped off. Since the load voltage has mainly a positive half cycle, the load current is direct and *discontinuous*, meaning that it flows in only one direction and has breaks. Thus, the rectifier is capable of operating in the first quadrant of the current-voltage plane, as Fig. 5, *b* shows; hence, it is called a *single-quadrant converter*.

In the case of resistive load,  $U_d$  is always positive and ac line current (the same as the rectified current  $I_d$ ) has the half-sine shape and flows in phase with voltage. The loads like motors have the properties of the resistive-inductive load; hence,  $U_d$  goes negative shortly, and ac line current (the same as  $I_d$ ) is out of phase with the voltage. When inductance aspires to infinity, the current waveform distorts and becomes almost rectangle.

I joined MITAS because  
I wanted **real responsibility**

The Graduate Programme  
for Engineers and Geoscientists  
[www.discovermitas.com](http://www.discovermitas.com)



**Month 16**

I was a construction  
supervisor in  
the North Sea  
advising and  
helping foremen  
solve problems

Real work  
International opportunities  
Three work placements



 **MAERSK**



The two-thyristor single-phase *full-wave rectifier* (*midpoint rectifier* or M2) is shown in Fig. 4, *c*. It produces a rectified rippled output voltage and current for each alternation of the ac input, as shows Fig. 5, *c*, for the case of the diode circuit. Inductive load causes current overlap designated by the *overlap angle*  $\gamma$ . The rectifier utilizes a center-tapped transformer that transfers alternating source voltage to the diode rectifier circuit. The anodes of each device **VS1** and **VS2** are connected to the opposite ends of the transformer secondary winding. The cathodes are then joined together to form a common positive output. The load motor **M** is connected between the common cathode point and the center-tap connector of the transformer. The transformer, two diodes or thyristors, and the load form a complete path for the current.

By adjusting the thyristor *firing angle*  $\alpha$  between 0 and  $\pi$ , a user can run the machine in both directions, but the load current and the motor torque are unidirectional as Fig. 5, *d*, displays. Thus, the rectifier is capable of operating in two quadrants of the current-voltage plane: the first quadrant is the rectifying mode of operation and the fourth quadrant supports the inverting mode of the operation. Therefore, it is a *two-quadrant converter* (Fig. 5, *e*). As long as the converter cannot produce the negative output current, the motor control signals and braking modes should be limited. In the inverting mode, it is more convenient to express the firing angle in terms of the *angle of advance* from the end limit of the interval available for successful commutation than as a delay  $\alpha$  from the beginning of the interval. This angle of advance shown in Fig. 5, *d*, is usually denoted as  $\beta$ . Then,

$$\alpha + \beta = \pi$$

$$\cos \alpha = -\cos \beta$$

To form a full-wave single-phase *bridge rectifier* (B2), four diodes or thyristors have to be interconnected, as Fig. 4, *d*, shows. Using four devices instead of two, this design eliminates the need for the center tap. During the performance of a bridge rectifier, two diodes are forward-biased in each alternation of the ac input voltage. When the positive alternation occurs, devices **VS2** and **VS3** are forward-biased, while **VS1** and **VS4** are reverse-biased. The conduction path follows from the ac source, through **VS2**, the load, then through **VS3**, and back to the source. This causes the same alternation to appear across the load. During the negative alternation, the current flows from the source through **VS1**, via the load, then through **VS4**, and back to the supply line. This causes the second alternation to appear across the load in the same direction as the first alternation. This means that voltage developed across the load is the same for each alternation. As a result, both alternations of the input appear as the output across the load and pulsating current flows via the dc output. The timing diagrams and the current-voltage plane of the circuit are the same as for the full-wave rectifier.

Replace **VS2** and **VS4** by the pair of capacitors, named **C1** and **C2**. In this half-bridge topology, a voltage doubling is obtained. **VD1** charges **C1** during the positive alternation of the supply voltage and **VD2** charges **C2** during the negative alternation. On the output of the rectifier, the sum of both voltages is presented.

**Three-phase rectifiers.** The *three-phase three-diode rectifier* circuit (midpoint rectifier, M3) produces a purer direct voltage than the single-phase rectifier circuits do, thus wasting less power. It is preferable to use a three-phase supply source, except at a fractional kilowatt, if such supply is available. In Fig. 4, *e*, the phases *L1*, *L2*, and *L3* of the three-phase source are connected to the anodes of thyristors **VS1**, **VS2**, and **VS3** via the transformer. The load motor **M** is connected between the cathodes of the thyristors and the neutral of the transformer. When the phase *L1* is at its positive value, maximum conduction occurs through **VS1** since it is forward-biased. No conduction occurs through **VS1** during the negative alternation of the phase *L1*. Other thyristors operate in a similar manner, conducting during the positive ac input alternation and not conducting during the associated negative ac alternation.

The rectifying diagram of a thyristor three-phase three-diode circuit is shown in Fig. 5, *f*. In the case of resistive-inductive load, the current continues through the diode or thyristor after the voltage has changed its sign. For that reason, the thyristor does not close at the zero-voltage instant, but remains open. By adjusting the thyristors firing angle, the negative voltage may be obtained, thus it is a two-quadrant converter again.

A commonly used six-pulse counterpart of this rectifier circuit is represented in Fig. 4, *f*. This three-phase bridge rectifier (B6) uses six diodes or thyristors. The anodes of thyristors **VS4**, **VS5**, and **VS6** are connected together at one point, while the cathodes of **VS1**, **VS2**, and **VS3** are joined at the other point. The load is connected across these two points. Therefore, the device connected to the most positive voltage will conduct in cathode group; the other two will be reverse-biased. As well, the device connected to the most negative voltage will conduct in anode group; the other two in this group will be reverse-biased. At least two devices are simultaneously in the open state here and at least one device from each group must conduct to facilitate the flow of the motor current. The voltage ripple is low because the output voltage consists of six pulses per voltage period (Fig. 5, *g*). The switching order of the thyristors in Fig. 4, *f*, is **VS1+VS6**, **VS6+VS2**, **VS2+VS4**, **VS4+VS3**, **VS3+VS5**, **VS5+VS1**. This circuit does not require the neutral line of the three-phase source; therefore, a delta-connected source as well as a wye-connected one could be used. Again, it is a two-quadrant rectifier. If the load possesses high inductance, the forward current continues on the negative anode voltage and the switching-off of the device is delayed. Since the previously opened devices are not closed after the opening the next devices, it is possible that three or even four devices are open during the commutation process. This means that there is more

than one open diode in the cathode or anode group and the current re-switches from one phase to another.

**Dual rectifiers.** In the previous circuits, the polarity of the load voltage may be changed, but the direction of the load current remains constant. In Fig. 6, a, the back-to-back connection of the two midpoint rectifiers has been produced to build a dual-controlled system. This is a *four-quadrant dual rectifier* because the negative current as well as the negative voltage may be produced here by the properly firing angle control (Fig. 6, b). Here, while thyristors **VS1**, **VS2**, and **VS3** pass the current, a rectifier operates in the first and fourth quadrants whereas since thyristors **VS4**, **VS5**, and **VS6** pass the current, the second and the third quadrants are active.

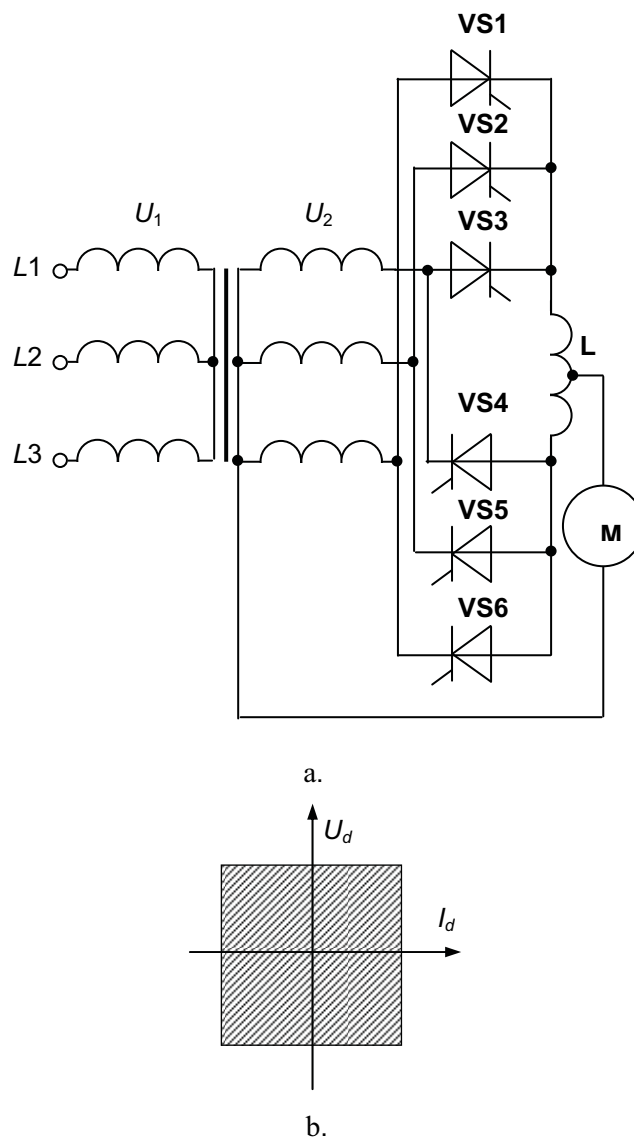

Fig. 6

In Fig. 7, the anti-parallel connection of the two bridge rectifiers has been arranged to provide the four-quadrant operation. Such circuit is by far the most common industrial four-quadrant dc system and is used in many demanding applications where rapid control is required. Usually, they incorporate additional features to enhance the safety of operation and to improve the control transients.

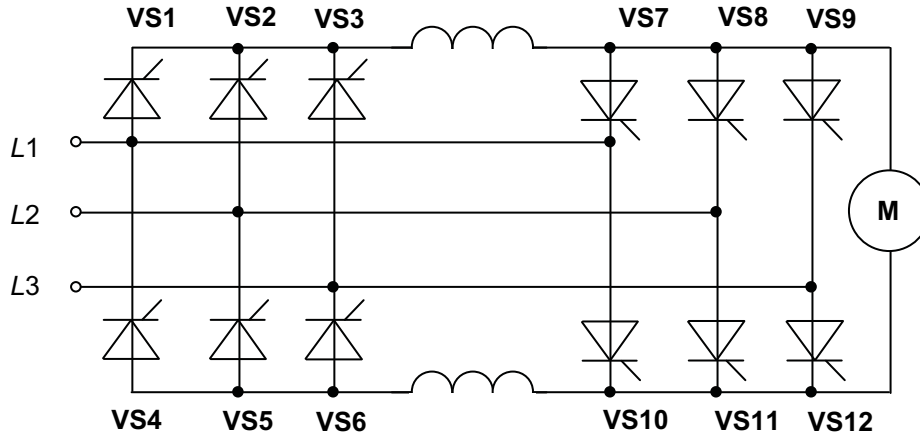

Fig. 7

**ie** business school

#1 EUROPEAN BUSINESS SCHOOL  
FINANCIAL TIMES 2013

#gobeyond

**MASTER IN MANAGEMENT**

Because achieving your dreams is your greatest challenge. IE Business School's Master in Management taught in English, Spanish or bilingually, trains young high performance professionals at the beginning of their career through an innovative and stimulating program that will help them reach their full potential.

- Choose your area of specialization.
- Customize your master through the different options offered.
- Global Immersion Weeks in locations such as London, Silicon Valley or Shanghai.

*Because you change, we change with you.*

www.ie.edu/master-management | mim.admissions@ie.edu | f t in YouTube



Today, dual converters with anti-parallel thyristors are produced in large numbers in the form of very compact units covering a wide power range from a few kilowatts to tens of megawatts. For the highest ratings, modular designs with air- and water-cooled heat sinks are available.

**Active rectifiers.** The use of diode and thyristor rectifiers leads to the problems of *electromagnetic compatibility* (EMC). Diodes and thyristors are the major contributors to power and current distortion problems, resulting in poor overall power factor, heating effects, device malfunction, and destruction of other equipment. It is remarkable that harmonics generated by rectifiers fall into the frequency spectrum up to about 3 kHz. They are conducted back into the power system producing a continuous distortion of the normal sinusoidal current waveform. The distortion frequencies are multiplies of the fundamental frequency 50 Hz shown in Fig. 8, *a*. Additional harmonic distortion occurs in the case of discontinuous current rectifier performance.

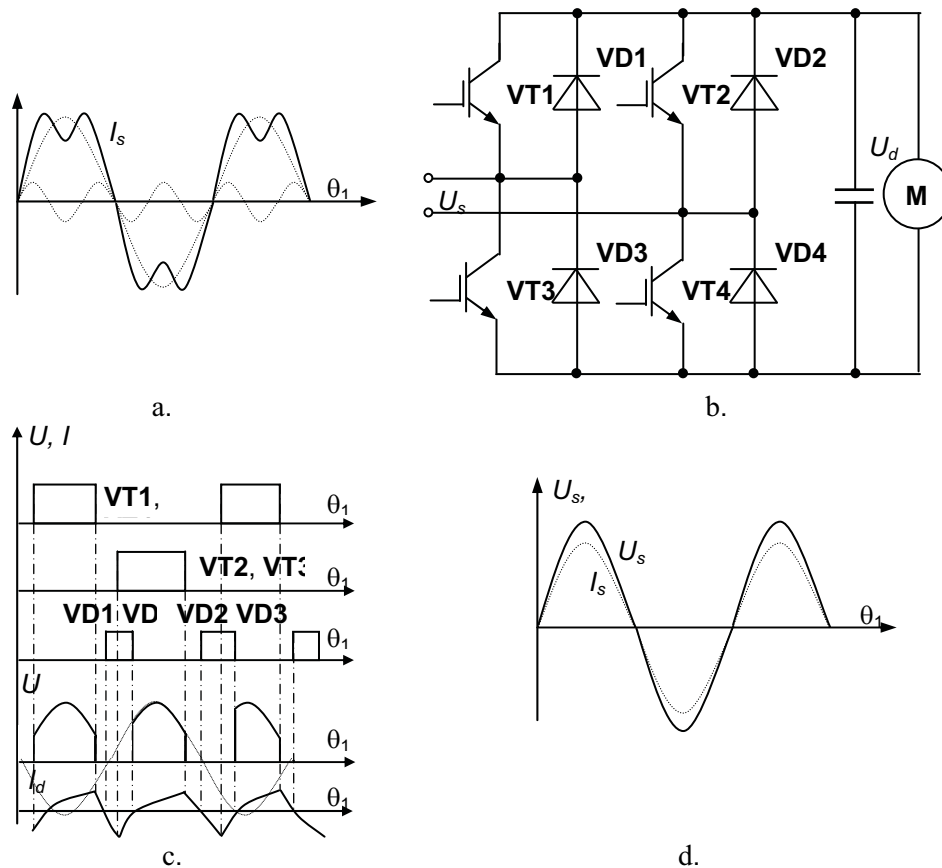

Fig.8

Along with the growing pulse number of rectifiers, the frequencies of high order harmonics increase whereas their relative magnitude decreases. Therefore, the trace of the input current becomes more sinusoidal, and the output current is smoothed better. On the contrary, when the firing angle of the rectifier grows, harmonic frequencies and their magnitude do

not change, but the phase shift of harmonics increases relative to the supply voltage. This effect causes the consumption of reactive power from the supply lines with the power factor decreasing. As a result, the demand for high quality power supply grows in the provision of unity power factor.

The recent standardization in EMC specifies limits for harmonic distortion, which may be met with a diode and thyristor rectifier circuit, accomplished by passive filters on the mains side. These, however, may be rather large and expensive. Further, in some EMC sensitive applications, the occurrence of harmonics in the rectifier, although filtered towards the supply mains, may disturb the operation of the whole system.

As an alternative, active rectifiers have been proposed. Interest in active rectifiers has grown rapidly over the decade due to some of their important advantages, such as power regenerative capabilities, dc voltage adjustment, low harmonic distortion of input currents, and high power factor.

*Active rectifiers* like those shown in Fig. 8, *b*, are built on transistors, which, unlike diodes and thyristors, are the full-controlled electronic devices with possible high-frequency performance. Mains would be connected here via inductors to the phase terminals  $U_s$  while  $U_d$  represents the dc output. This single-phase full bridge can be used as a rectifier and an inverter; thus, it permits bi-directional energy transfer, which is useful for applications with energy recovery. However, the circuit contains twice the amount of the switches compared to the passive rectifier.

A variety of control strategies have been invented for this type of converters and their operational principles differ essentially. Although many control methods are known and implemented, there are two ways of circuit performance in terms of the active rectifier. According to the first of them, the classical self-commutated bridge rectifier passes a positive current without affording any control function. To pass a negative current for the motor braking, the transistors must be open in the switching mode. As far as the second way is concerned, the transistor bridge rectifies a current and controls the rectified voltage, whilst the freewheeling diodes pass the negative current in the regeneration period without voltage control, as shows Fig. 8, *c*, for all diodes simultaneously. In both cases, current may be positive and negative. Clearly, the gate adjustment of the switches is more complicated than this of thyristors because of the need in synchronization with the supply net and specific inductor; thus driving effort is somewhat higher.

Fig. 8, *d*, depicts the waveforms of mains voltage (solid) and mains current (dotted). Due to the sinusoidal shape of current, there would be no harmonic content. Furthermore, the zeroing phase angle between voltage and current traces avoids the occurrence of first harmonic



reactive power. At the same rectified power, the rectifier input current has a significantly lower amplitude and rms value compared to a passive rectifier.

The topology of the three-phase *Vienna rectifier* is shown in Fig. 9, *a*; it can be characterized as follows. Each phase has an inductor on the supply side. The output represents a circuit with a controlled dc voltage and center point. It is advantageous that due to this division of the output voltage, the switches will need lower blocking voltage and thus better conduction characteristics can be used.

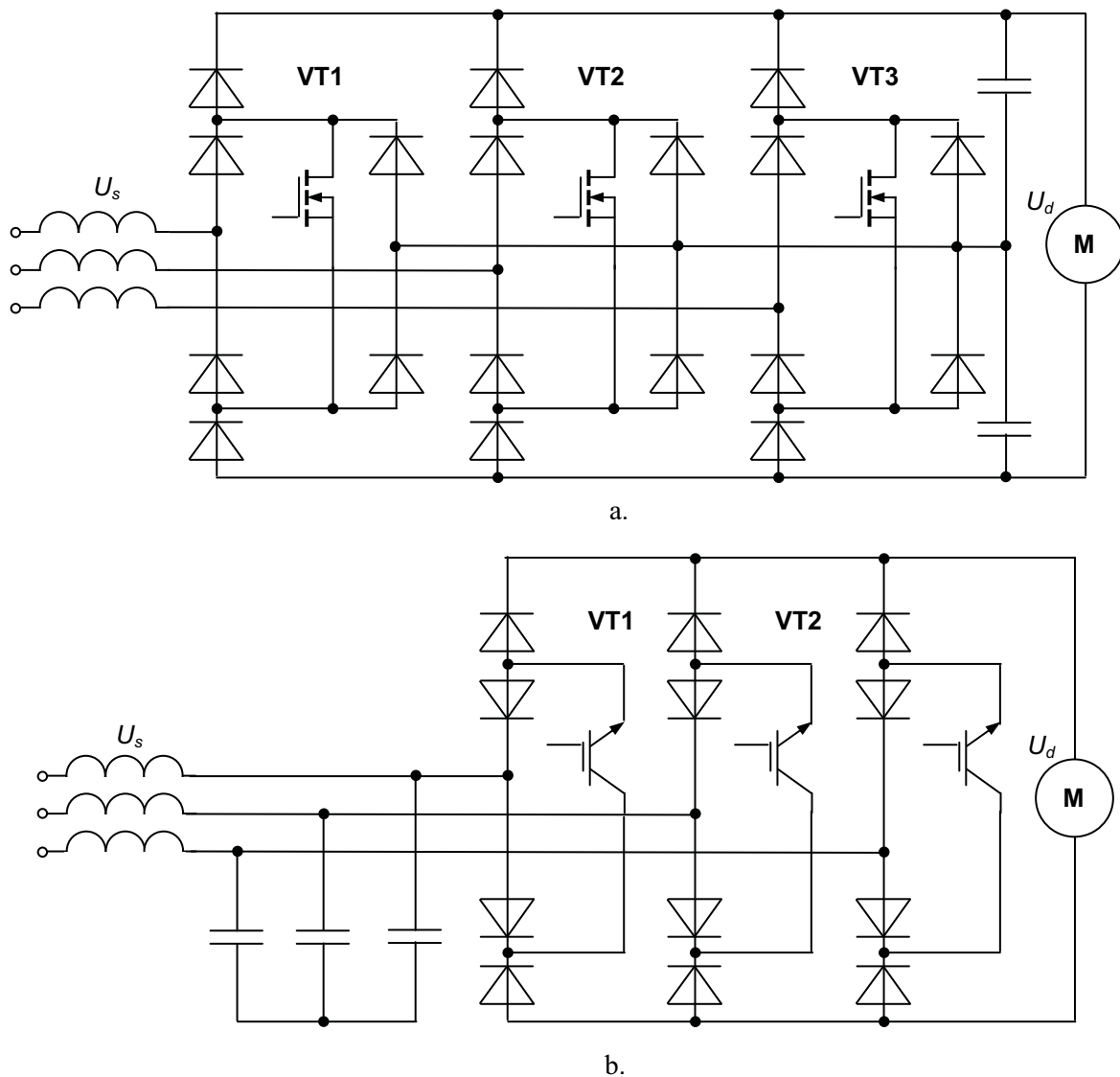

Fig. 9

There is one controllable switch per phase: MOSFETs are depicted. Together with the surrounding four-diode bridges, they operate as bi-directional switches. When turned on, they connect the respective mains phase to the dc center point via the two diodes and the inductor, which makes the letter magnetize. When turned off, the inductor demagnetizes



into the dc load through the freewheeling diodes connected to the positive and negative load terminals, respectively.

The circuit in Fig. 9, *b*, is again connected to the three-phase mains via one inductor per phase. Contrary to the Vienna rectifier, capacitors are located on the mains side of the converter and a dc voltage is adjusted between the positive and negative load terminals on the output side of the rectifier. The circuit uses bi-directional switches consisting of diodes and transistors: IGBTs are depicted in this case. Rectifying and inverting modes of operation are possible here, similarly to the previous circuit. In the rectifying phase, the switches are off, whereas during the inverting phase a pair of switches is on.

**Summary.** A single-phase half-period rectifier is the simplest one. Nevertheless, it has inadequate secondary current shape, very high ripple level, and very low power factor.

The main disadvantage of the two-diode midpoint rectifier is the requirement of a center-taped transformer.

A single-phase bridge rectifier uses the transformer and semiconductor devices more effectively; its current shape is more sinusoidal. That is why it is the best decision for low-power (up to 1 kW) applications.



"I studied English for 16 years but...  
...I finally learned to speak it in just six lessons"  
Jane, Chinese architect

ENGLISH OUT THERE

Click to hear me talking before and after my unique course download

Single-phase rectification results in two identical pulses per cycle in the rectified dc-side voltage, whereas three-phase rectification in three and more such pulses occurs. Therefore, three-phase rectifiers are superior in terms of minimizing distortion in line currents and ripple of the load voltage. Low degree of the transformer use and low power factor are the main disadvantages of the three-phase three-diode rectifier. Nevertheless, sufficiently high quality of rectified voltage with small ripples is its main advantage.

The three-phase bridge rectifiers are predominant because of their good technical properties: low ripple, high power factor, simple topology, and low price. Today they are used both in powerful and in small-power supplies as well as in AC/AC converters with a dc link.

Active rectifiers outperform the passive rectifiers with the following characteristics:

- occurrence of harmonics in supply current is actively minimized
- in operation, the intermediate circuit is charged during the whole mains period with rectified sinusoidal supply current in phase with the supply voltage; this way, the maximum active power is available through a given mains fuse
- rectified voltage and current are controlled thus the output is independent of the supply voltage over a wide range; this helps to overcome possible problems of unstable supply voltage and there is no necessity to manually pre-select the input voltage
- only few and small passive components are required

It can be expected that this technique, which up to now is used rather seldom, will gain importance in the near future.

## 1.2 DC/AC CONVERTERS – INVERTERS

**Inverting.** *DC/AC converters* named *inverters* are employed to convert a dc supply to an ac level of a definite frequency and value. Controlled semiconductor devices, such as transistors, SCR, and GTO thyristors are used in inverters. The input dc voltage may come from the rectified output of a power supply. Alternately, the input dc may enter from an independent source, such as a dc voltage source, a fuel cell, or a battery. In these systems, the supply voltage  $U_d$  directly feeds a converter. Typical voltages of dc supplies in vehicles are 12, 24, 48, or 80 V, which are appropriate to make MOSFETs and IGBTs the preferred switching elements. The dc source is able to generate energy for motoring operation of the drive and to sink regeneration energy in the braking operation.

Inverters are usually designed to provide either three-phase or single-phase output. Larger industrial applications require three-phase ac. Low-signal half-wave inverters pass electrical energy during one alternation. These inverters supply loads of 100...200 W powers.

Another classification refers to offline and online inverting. If an inverter is the only source of the load ac line, it is called an *offline inverter* or *autonomous inverter*. On the other hand, if an inverter is a part of the common power supply line, it is known as an *online inverter* or a *line-fed inverter*.

In accordance with the circuit arrangement classification, the voltage source inverters and the current source inverters are distinguished. A *voltage source inverter (VSI* or *voltage stiff inverter)* forms the voltage with required properties: magnitude, frequency, and phase. It is the most commonly used type of inverter. This inverter has the low internal impedance. Generally, it has a capacitor of high capacity connected across the supply source that keeps constant input voltage. The switches of VSI are constructed on the base of the full controlled devices (transistors, GTO thyristors, or MCT). If bi-directional current is required, the *freewheeling diodes* called also *feedback diodes* are connected across the switches.

Alternately, a *current source inverter (CSI)* is the source of the current with the required properties: magnitude, frequency, and phase. As a rule, it has an inductor connected in series with the supply source that keeps the current constant. The switches of the inverter periodically change the output current direction, and the load has very low impedance. Thus, the output voltage of the CSI is shaped according to the voltage drop on the load caused by the output current.

**VSI.** In Fig. 10, *a*, a half-bridge midpoint configuration of the single-phase VSI is represented. BJTs, MOSFETs, IGBTs, GTO thyristors, or force-commutational SCRs usually play the role of switches **VT1** and **VT2**. Switches **VT1** and **VT2** arrange the dc source with the common terminal to supply motor **M**. Waveforms are shown in Fig. 10, *b*. During the positive half-cycle of the output voltage, switch **VT1** is turned on, which gives  $U_s = +0,5U_d$ . During the negative half-cycle switch **VT2** is turned on, giving  $U_s = -0,5U_d$ . Note that prior to turning on a switch, the other one turns off; otherwise, both switches will conduct and short the dc supply.

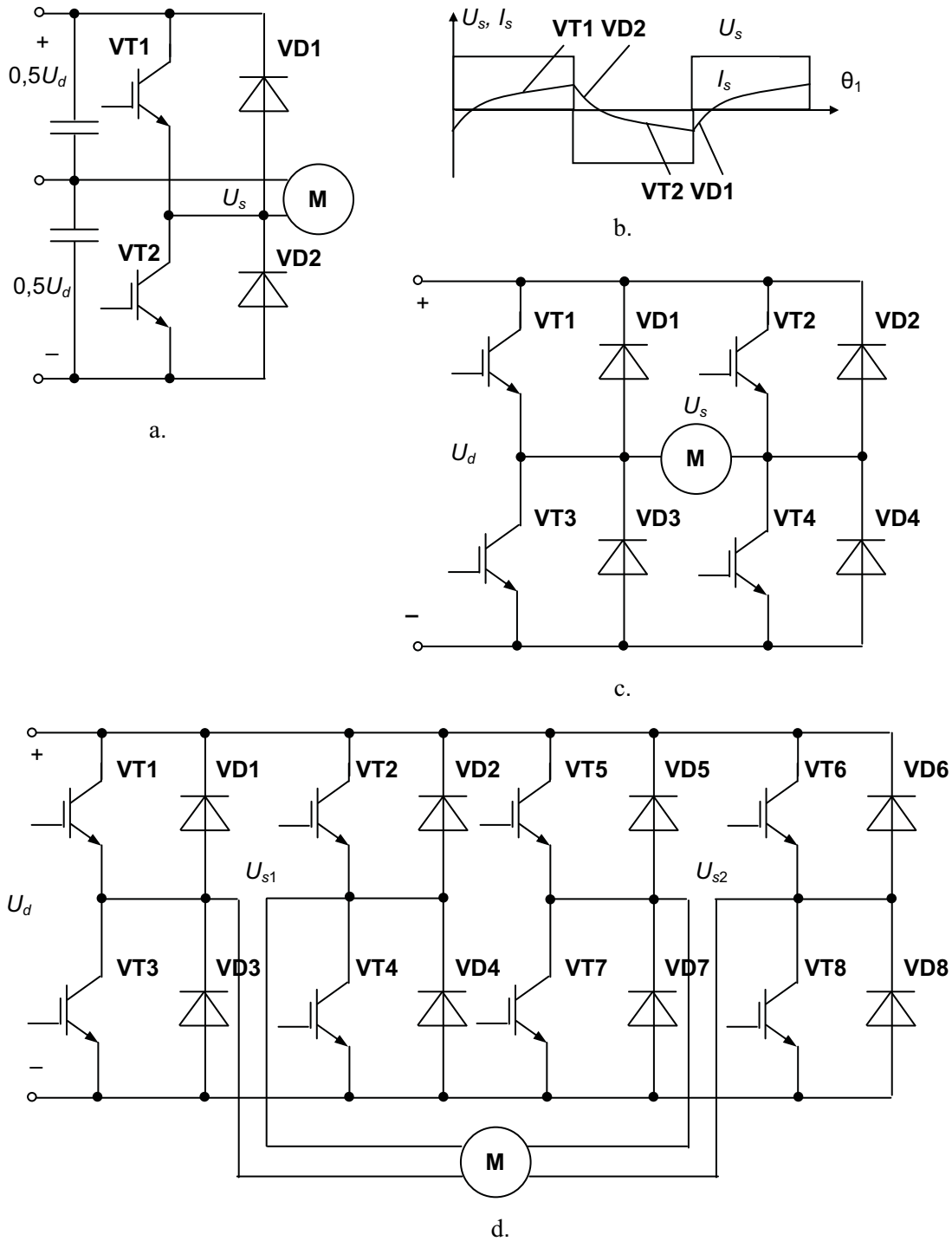

Fig. 10

Usually, the load is reactive; therefore, the output current flows as shown in Fig. 10, *b*. Freewheeling diodes **VD1** and **VD2** feed the reactive energy of motor **M** back to the supply line. While  $U_s$  is positive during  $0 < t < 0,5T$ , either **VT1** or **VD1** is conducting. However, since  $I_s$  becomes negative at the beginning of the phase, **VD1** must be conducting during this part of the interval. Thus, the feedback diodes conduct when the voltage and current are of opposite polarities.

Figure 10, *c*, illustrates the single-phase full-bridge VSI. Each of its legs includes a pair of transistors with anti-parallel discharge circuits of reverse current built on the freewheeling diodes. These back diodes provide an alternate path for the inductive current, which continues to flow when a switch is turned off. Again, the diodes return the regenerated power to the dc supply whilst the switches carry the reactive voltage.

Figure 10, *d*, shows an example of the converter which provides the frequency control of the two-winding induction motor **M**. The circuit includes a pair of single-phase full-bridge VSIs. The first of them drives the control winding of the motor and the second bridge supplies the exciting winding.

The most frequently used three-phase bridge VSI is shown in Fig. 11, *a*. It consists of three legs, one per each phase. All inverter legs are equal; therefore, the output of each leg depends only on the dc supply voltage and on the switch status. The output voltage is independent of the magnitude of output load current.

Excellent Economics and Business programmes at:



university of  
 groningen



“The perfect start  
 of a successful,  
 international career.”

**CLICK HERE**  
 to discover why both socially  
 and academically the University  
 of Groningen is one of the best  
 places for a student to be

[www.rug.nl/feb/education](http://www.rug.nl/feb/education)

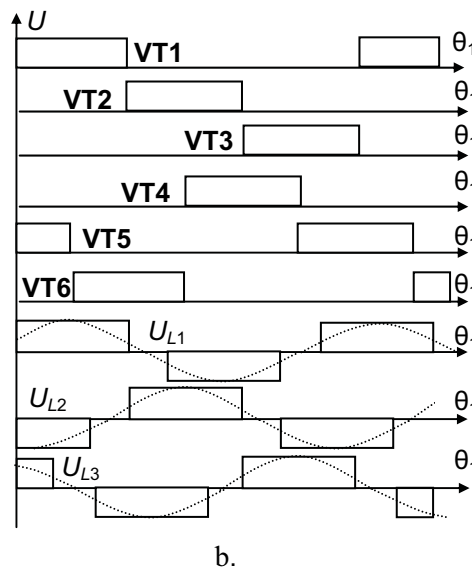
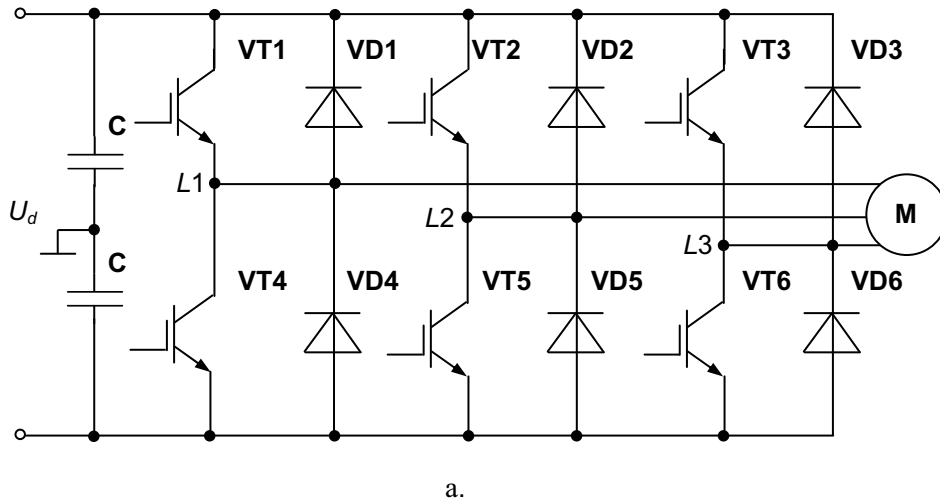

Fig. 11

Different modes of the transistors switching on and off may be proposed for this circuit. For example, the possible switching sequence is the next: **VT1–VT6–VT2–VT4–VT3–VT5–VT1...** In this case, two transistors are together in on state each time span and the output voltages have a rectangle shape, as shown in Fig. 11, *b*. The firing of the three legs is phase-shifted by 120°. When **VT1** is fired, point *L1* is connected to the positive terminal of the dc supply, giving  $U_{L1} = 0,5U_d$ . When **VT4** is fired, point *L1* is connected to the negative terminal of the dc supply, giving  $U_{L1} = -0,5U_d$ . Waveforms of *L2* and *L3* are the same as those of *L1*, except that they are shifted by 120°. Since each transistor is switched off, its counterpart freewheeling diode passes the tail current in the previous direction. For example, when **VT1** turns off, **VD4** passes the current until it falls down to zero as the timing diagram shows.

The fundamental harmonic shown by dotted lines predominates here. Other switching combinations are accessible also and will be discussed later.

**High-voltage operation.** The problematic mode of an inverter performance concerns obtaining the output voltage, which is higher than the input one. Limitation of the maximum voltage of the switches places the converters either in a restricted area, strongly dependent on the maximum converter voltage, or in the need of associations or more expensive switches, which allow the desired conversion. One of the typical solutions that foresee the use of transformers is given in Fig. 12, a. It is an example of a three-phase VSI built on the three single-phase bridges and three single-phase transformers. Thanks to the star connection of their secondary windings, there is no zero-sequence current in the load. Thanks to transformers, the switching voltage is low enough, thus helping to avoid the switching overvoltages.

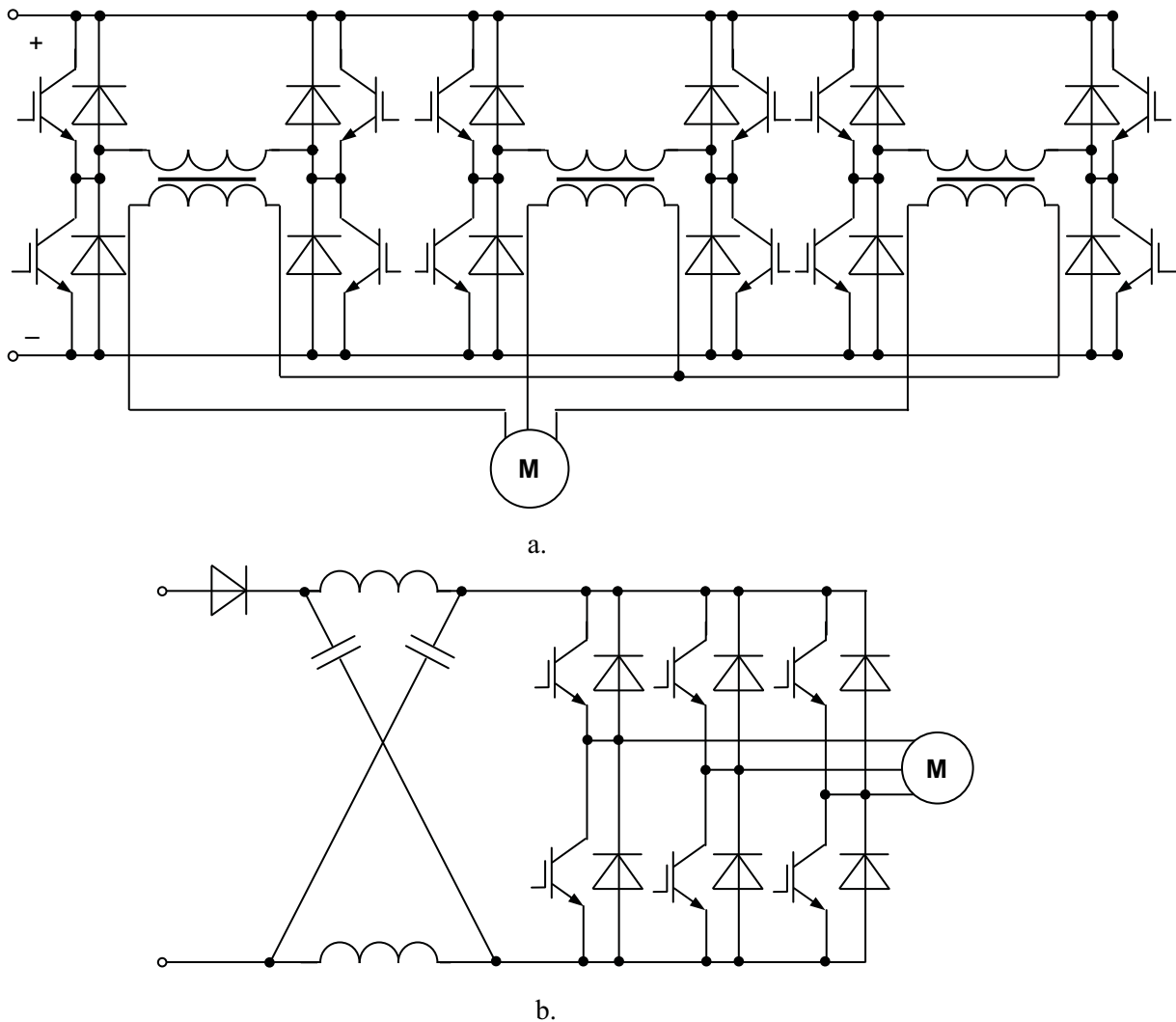

Fig. 12



Worth attention seems to be the *Z-inverter* patented by F.Z. Peng in 2003. Its VSI solution is given in Fig. 12, b. In contrast to conventional VSI and CSI inverters, the front-end of the *Z-inverter* includes a diode and a *Z*-source of “X” shape, composed of two capacitors and two chokes. In voltage *Z-inverter*, the diode prevents forbidden reversed current flow, whereas in current *Z-inverter* – reversed voltage. For this reason, application of the basic *Z-inverters* is possible only if energy return to the input source is unnecessary, particularly in the fuel cell or photovoltaic cell.

Unlike the conventional bridge inverter, the *Z-inverter* can assume an additional state defined as a *shoot-through* state, which occurs when the load is shorted simultaneously by the top and bottom groups of transistors. The main and unique characteristic of the *Z-inverter* is that the shoot-through state permits to raise the output voltage above the input value. Here, a diode is polarized reversely and does not conduct the input voltage to the inverter therefore energy stored in capacitors is transferred to the chokes. In the non-shoot-through state, when working combinations of the inverter switches are possible, the diode conducts and the voltage changes from 0 to the maximum:

$$U_d = U_{d\ sup} \frac{1}{1-2q},$$

where  $q = \frac{t_{on}}{T_c}$  – the shoot-through duty factor, satisfying a requirement  $q < 0,5$  and  $t_{on}$  – the shoot-through time span in the switching period  $T_c$ .

The main advantages of the *Z-inverters* are:

- increase and decrease of voltage in the one-step energy processing, that is lower costs and decreased loses
- protection from the short circuits in the inverter branches and from opening of the circuits that improve resistance to failure switching and EMI distortions
- relatively simple start-up resulting in lowered current and voltage surges

**Multi-level inverters.** A number of topological variants of the multi-motor applications supply have been proposed. Among them, “single converter – all loads” and “single converter – single load” are the most popular designs. The first topology has often the lowest cost, an average control complexity, good dynamic and static characteristics, and sufficient reliability. At the same time, it requires an additional project development stage and non-standard maintenance arrangement. The second topology is based on standard components and design decisions, though it is more costly, and its control problems arise when the load interconnection is significant.

Today multi-level inverters are the preferred choice for high voltage and high power applications. As the voltage level increases, power circuit complexity will rise as well. A common-mode power circuit of the traction two-motor drive is shown in Fig. 13. To obtain higher voltage possibilities, a couple of series-connected switches built on IGBTs have been added into each leg here. Of course, their introduction results in additional power losses in the circuit, such as conducting losses, blocking losses, and switching losses.

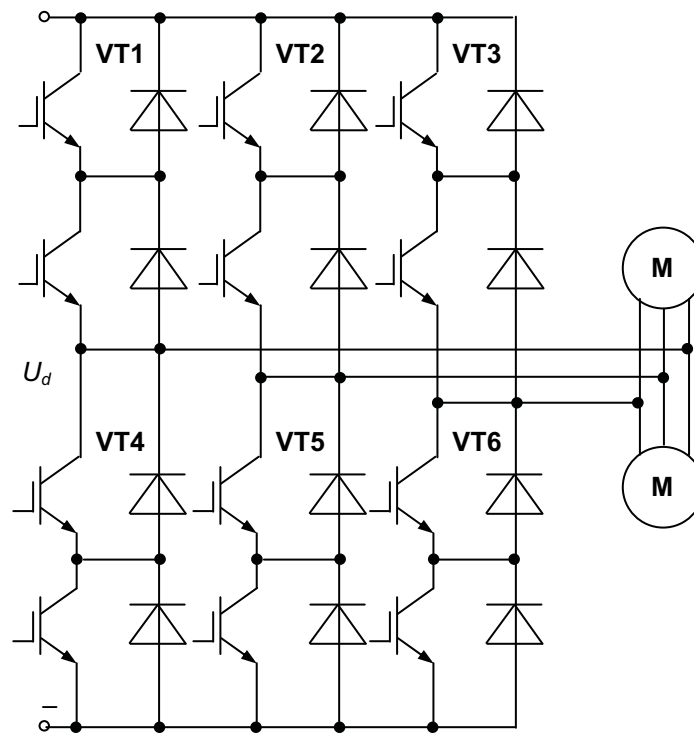

Fig. 13

A typical feature of the traction drive is the current unbalance of the phases due to the different loading of the phases, slip, and speed. It results in the leakage currents on the legs and causes control problems. Moreover, due to the switch inequality the current unbalance leads to the voltage unbalance, thus the overheating of the transistors may cause additional power consumption. To avoid unwanted currents and power losses, specific circuit configurations are proposed to drive interconnected motors in the papermaking industry, metallurgical aggregates, traction units, and in other areas.

A five-leg inverter for the coupled-motor system supply is shown in Fig. 14, *a*. It is constructed by adding two legs to the conventional bridge topology. One of the five legs is a common leg connected with one of the three-phase terminals of each motor, and four other legs are connected with the other two terminals of each motor.

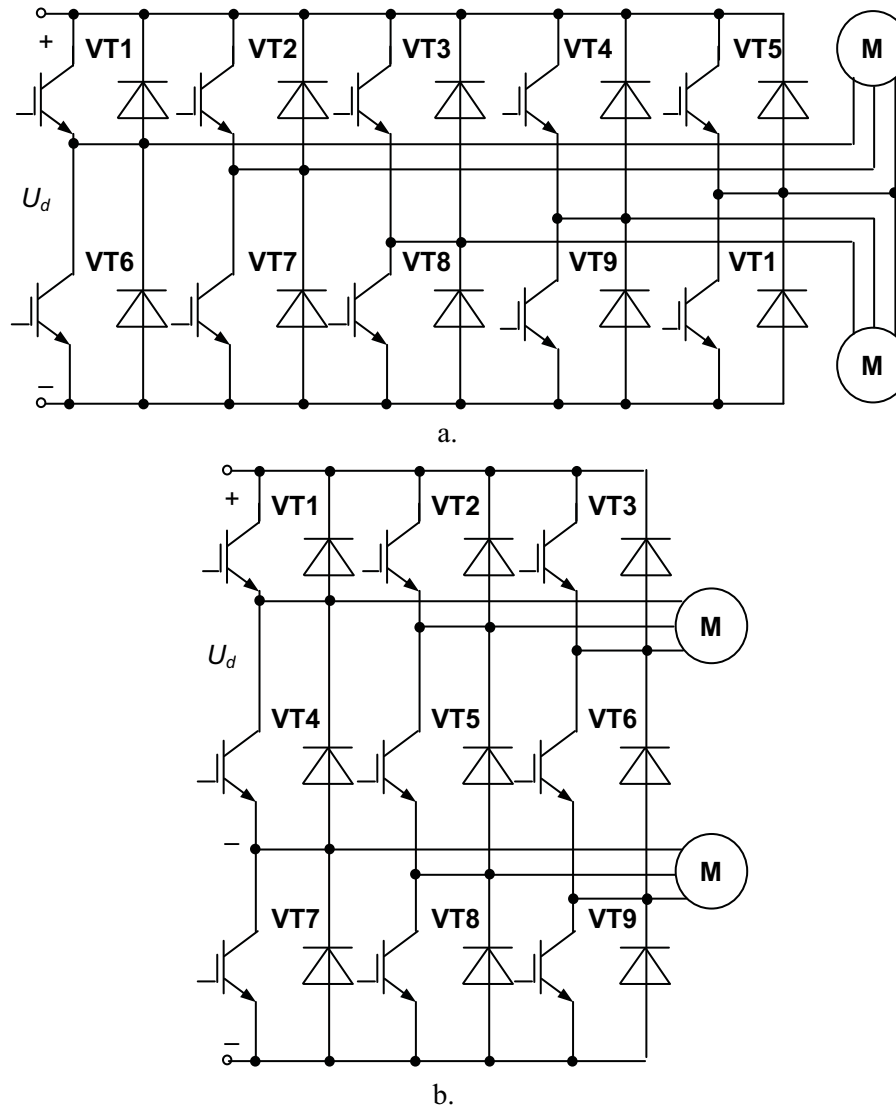

Fig. 14

A nine-switch inverter proposed to control the same coupled motor system is shown in Fig. 14, *b*. This circuit can be considered as an interleaved topology of an upper-side inverter built on switches **VT1...VT6** and a lower-side inverter, which includes switches **VT4...VT9**. Both inverters may be controlled both jointly and alternately.

**CSI.** A thyristor single-phase forced commutated CSI is shown in Fig. 15, *a*. Here, the single-phase bridge plays the role of the commutator. For the current source mode, an inductor is included in the input circuit of the inverter. A capacitor is placed in the output as an energetic buffer between the pulsing inverter and the load. In addition, the capacitor is the instrument of the thyristors forced commutation. While the thyristors **VS2** and **VS3** conduct current, the input voltage charges the capacitor. Since thyristors **VS1** and **VS4** switch on, **VS2** and **VS3** obtain the reverse voltage of the charged capacitor, which helps them to close immediately. The capacitor begins recharging to the other polarity, finishing it before

the next switching instant. The higher is the current, the faster the capacitor recharging and the forced commutation intervals are shorter.

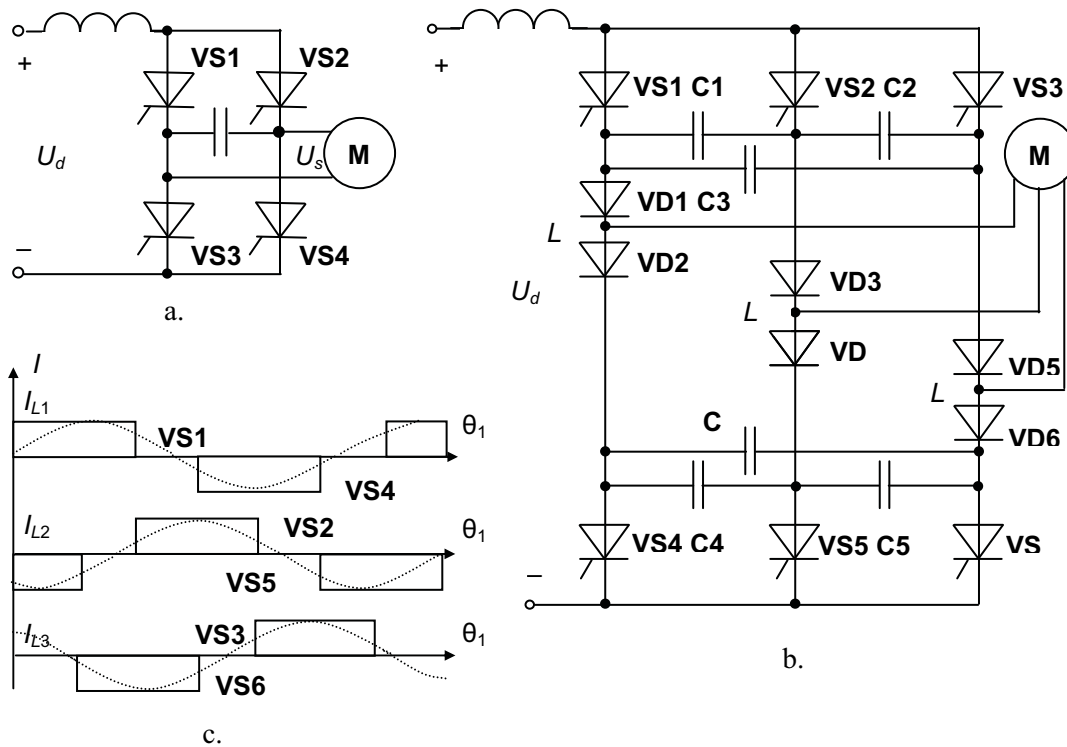

Fig. 15

## American online

# LIGS University

is currently enrolling in the  
Interactive Online **BBA, MBA, MSc,**  
**DBA and PhD** programs:

- ▶ enroll **by September 30th, 2014** and
- ▶ **save up to 16%** on the tuition!
- ▶ pay in 10 installments / 2 years
- ▶ Interactive Online education
- ▶ visit [www.ligsuniversity.com](http://www.ligsuniversity.com) to find out more!

Note: LIGS University is not accredited by any nationally recognized accrediting agency listed by the US Secretary of Education. More info [here](http://www.ligsuniversity.com).



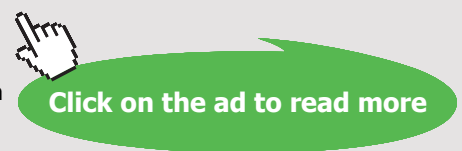

The thyristor forced commutated CSI are the most widely used systems at power levels in the range 50 to 3500 kW at voltages up to 700 V. The high-voltage versions 3,3/6,6 kV have been developed, however, they have not proved to be economically attractive. Figure 15, *b* shows a thyristor forced commutated three-phase CSI. The dc current taken from the current source is sequentially switched with the required frequency into the load. The circuit commutation transient may be described as follows. With no commutation in progress, two thyristors, for example, **VS1** and **VS6** carry the dc while capacitor **C1** is positively charged because of the preceding commutation. If thyristor **VS2** is now turned on, **VS1** is extinguished in a rapid transient and **VS2** assumes the dc. This is the starting condition of the commutation transient. While the current in the *L1* phase is now reduced towards zero, the current in the *L2* phase is rising. During this interval, the *L1* phase is fed through the capacitor **C1** as well as the series connected capacitors **C2** and **C3**. Eventually, diode **VD1** is blocked and the commutation is completed while **VS6** and **VS2** are conducting. The diodes are required for decoupling in order to prevent the capacitors from losing their charge necessary for the next commutation. Without these diodes, a capacitor would discharge through two phases of a load.

Idealized waveforms of the output currents are shown in Fig. 15, *c*. Each thyristor conducts in 60 electrical degrees. When a thyristor is fired, it immediately commutates the conducting thyristor of the same group (top group **VS1**, **VS2**, **VS3** or bottom group **VS4**, **VS5**, **VS6**).

The first harmonic of the load current waveform is predominant, except when the superposition of voltage spikes caused by the rise and fall of the load current at each commutation. The operating frequency range is typically 5 to 50 Hz, the upper limit being set by the relatively slow commutation process. This system is used to feed the single-motor ac drives of fans, pumps, extruders, compressors, etc., in which good dynamic performance is not required and an inferior power factor, which comes down along with the speed falling, is acceptable.

Conventional three-phase CSI built on IGBTs is shown in Fig. 16. Commonly, it has the large inductor connected in series to the supply source, which keeps the current constant as well as the capacitor bank across the output. Capacitors are required to filter the current harmonics, to make the load current essentially sinusoidal, and to reduce voltage spikes.

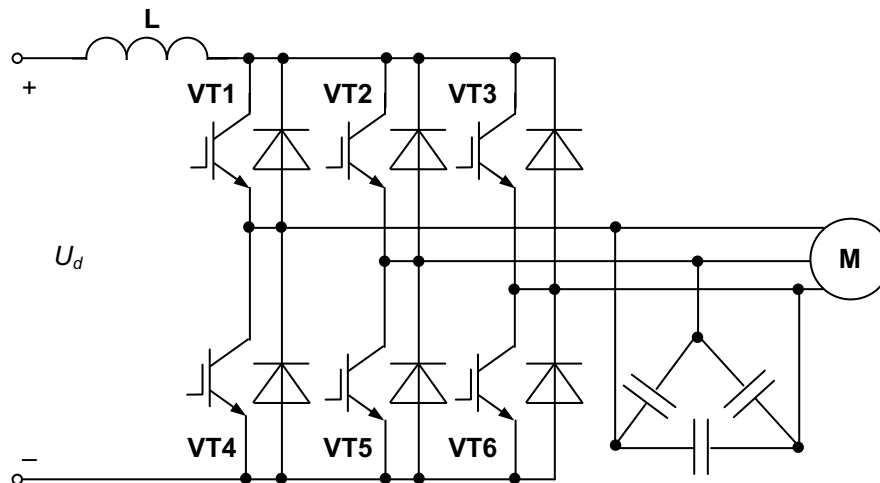

Fig. 16

**Resonant inverters.** In all topologies discussed above, the electronic devices operate in a switch mode where they are required to turn on and off the entire load current during each switching. In these operations, switches are subjected to high stresses and high power loss that increases linearly with the switching frequency. During turn-on, simultaneous current growth and voltage extinction occur in the switches, whereas in the case of turn-off the exact opposite occurs – simultaneous current extinction and voltage growth. In both situations, in real power switches, significant switching losses occur. Another significant drawback of these operations is an electromagnetic noise produced due to the large current and voltage transients. For that reason, the typical switching frequency of the hard switching applications is limited to a few tens of kilohertz (depending on the type of power). These shortcomings of switching converters are exacerbated if the switching frequency is increased in order to reduce the converter size and weight and hence to raise the power density, while maintaining high efficiency.

Contemporary trend is to design DC/AC converters operating at as high switching frequency as possible (from 2 kHz in high power to 200 kHz and more at low power ratings) using fast-switching MOSFETs. As long as at high switching frequency the mentioned negative effects rise to an inadmissible level, dissipative passive snubbers and active snubbers with energy recovery were introduced. Particularly, the turn-on **L-R-VD** snubber built in series with the transistor allows decreases maximum value of the transistor current and current stress, limiting the turn-on switching losses and transferring them to resistor **R**. The turn-off snubber **C-R-VD** built across the transistor allows one to transfer turn-off switching losses from the transistor to the resistor **R**. Therefore, it decreases the maximum voltage in the transistor. In such a manner, the snubbers produce a more secure switching trajectory of transistors.

In the modern high power electronic converters, the number of snubbers is minimized or they are not used at all. This results from the fact that new power switches are developed as well as from the pursuit of cost decreasing. Obviously, semiconductor devices are then more loaded and should be over-dimensioned.

In such cases, more and more novel solutions are applied in which *soft switching* is employed instead of traditional *hard switching*. This concept consists in utilization of resonant tanks in the converters in order to create oscillatory voltage and/or current waveforms. In such a case, *Zero Voltage Switching (ZVS)* or *Zero Current Switching (ZCS)* conditions can be created for the power switches.

To realize high frequencies, the switching processes should be produced when the voltage across the switch and/or current through it is zero at the switching instant. With miniaturization being one of the main driving forces for the development of innovative power electronics, resonant converters have attracted considerable attention. *Resonant inverters* are the switching converters, where controllable switches turn on and off at zero voltage and/or zero current. In that way, high switching frequencies can be realized without pushing switching losses to desirable levels. Therefore, less volume has to be provided to decrease dissipation losses and reactive components can be reduced in size, resulting in designs that are more compact.

Typically, resonant inverters are defined as the combination of different inverter topologies and switching strategies. The power flow to and from the load is controlled by the resonant impedance, which in turn is adjusted by the switching frequency. The following three compositions of the resonant circuit and the load are widespread:

- series resonant inverters using the series connection of the load and the series tank circuit
- parallel resonant inverters having a parallel connection of the load and the inductor or the capacitor of the tank circuit
- series-parallel resonant inverters with the load connection across the part of the tank circuit

Another classification is based on the place of the inductor in the inverter circuit:

- supply-resonant inverters having an inductor in the dc side
- in the load-resonant inverters, an inductor is placed in the ac side

Parallel and series-parallel ZCS resonant inverters are shown in Fig. 17, *a*, *b*. They are similar to the CSI although their parameters are strongly different. Here, the input inductor and the output capacitor arrange the resonant circuit with the switching bridge placed between



them. Parameters of the tank circuit and the bridge switching frequency are selected by such that the input current has a discontinuous behavior, as Fig. 17, *c* shows. Thanks to this choice, bridge transistors switch off when the current falls down to zero. When the transistors switch on ( $t_0$ ), the capacitor charges through the reactor to the voltage  $U_C$ , which is higher than the supply voltage  $U_d$ . However, in the  $t_1$  instant current falls to zero, thus, transistors get inverse voltage. During the current delay ( $t_1 t_2$ ) the capacitor discharges. Then ( $t_2$ ) the next pair of the transistors switches on without current again. From  $t_3$ , the capacitor voltage changes the polarity. Thanks to zero-current switching, switching losses are low, thus the frequency may be increased significantly.

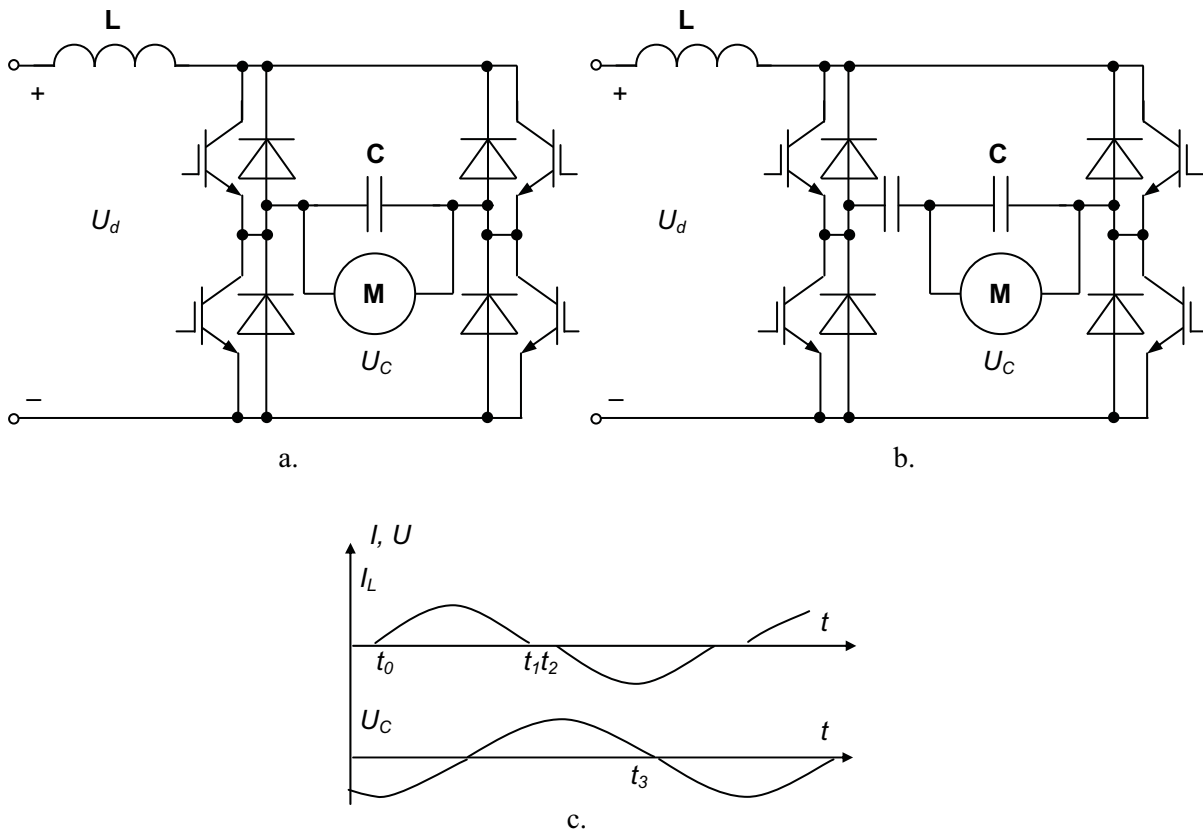

Fig. 17

Half-bridge, midpoint, and full-bridge ZCS series resonant inverters are shown in Fig. 18, *a*, *b*, *c*. Unlike the parallel inverters, the capacitor voltage of the tank circuit does not fall down during the zero-current delay, but the load current is discontinuous here.

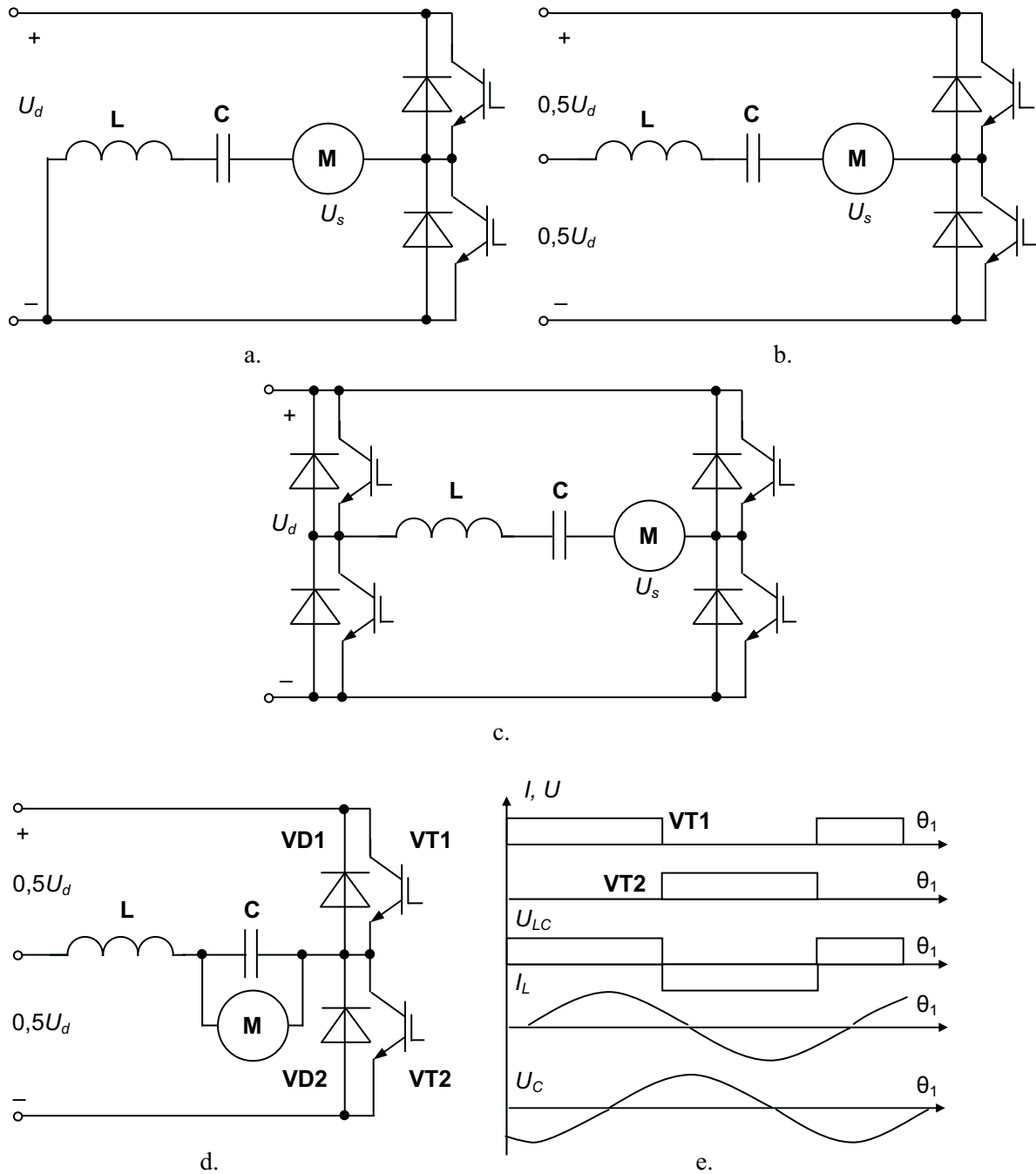

Fig. 18

The series-parallel ZCS resonant inverter and its timing diagrams are given in Fig. 18, *d, e*. Since **VT1** switches off, current flows through **VD2**. When current decreases to zero point, the capacitor begins to discharge. Further, the current flows via **VT2**. On that interval, the capacitor charges with the other polarity. Further, the processes repeat similarly.

As usual, the limitation of the maximum MOSFET voltage restricts converter effectiveness; nevertheless, the transformers help to solve the problem. This situation is more and more

frequent, like in fuel cell systems, in which the input voltage is low, normally between 25 V and 60 V, and the required output voltage is usually compatible with standard ac values, normally between 110 V and 230 V. It means that the voltage ratio is between 5 and 9 when the fuel cell is operating at the rated power.

The resonant inverters displayed in Fig. 19 consist of switching circuits **VT1...VT4** and **LC** resonant circuits, thus forming an alternating low voltage. The maximum frequency of the tank circuit **LC** is near the communication frequency of the switches. Further transformers step the voltage up to the value required by the load motor.

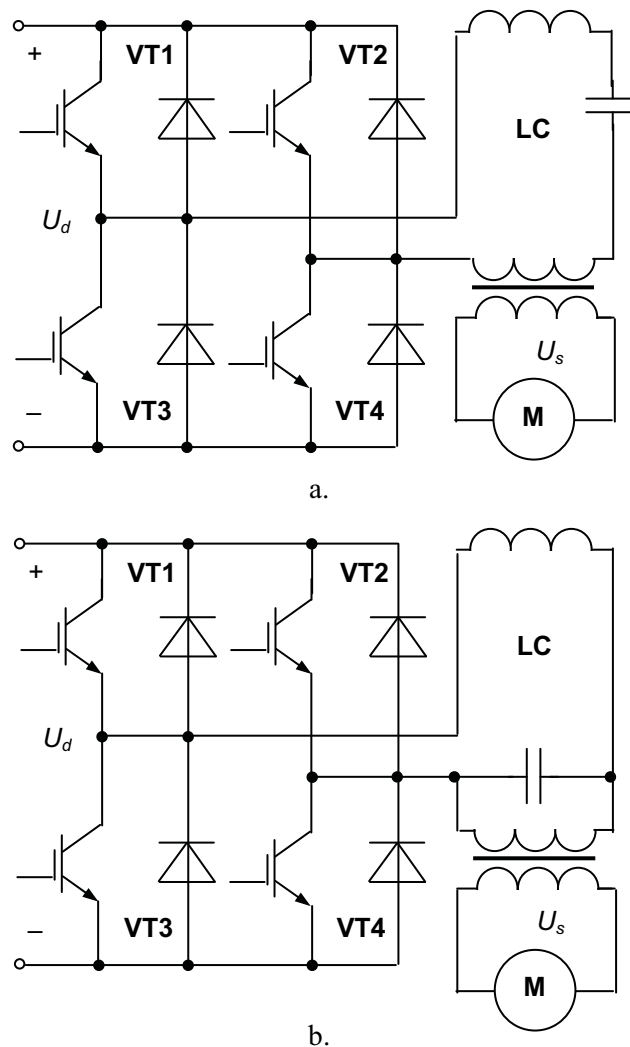

Fig. 19

**Summary.** In practice, single-phase inverters are used when the power of the load is 100...200 W. On the output side, this most commonly used inverting approach provides the functions of a voltage source. An effective VSI implementation method involves the use of the transistor bridges with freewheeling diodes.

CSIs can be used for such electrical equipment that needs the control of the current value, particularly in controlled-torque drives. As compared to the VSIs, they are not so popular because of the large input inductor and the requirement in a resistive-capacitive load. Switching frequency of a CSI is smaller, so the load current waveform is distorted, leading to larger derating of the load to avoid overheating. Thereat, instead of a CSI, in electric drives the VSI are used as a current source in which an appropriate current feedback arrangement is used.

In resonant inverters, the controllable switches turn on and off at zero voltage and/or zero current that opens the way to the frequency increasing. Therefore, less volume is required for the converters and reactive components can be reduced in size, resulting in design that is more compact and attracting the attention of portable drive designers. Unfortunately, the frequency of the resonant inverters cannot be changed by the reference signal of the control system.



- The number 1 MOOC for Primary Education
- Free Digital Learning for Children 5-12
- 15 Million Children Reached

**About e-Learning for Kids** Established in 2004, e-Learning for Kids is a global nonprofit foundation dedicated to fun and free learning on the Internet for children ages 5 - 12 with courses in math, science, language arts, computers, health and environmental skills. Since 2005, more than 15 million children in over 190 countries have benefitted from eLessons provided by EFKI. An all-volunteer staff consists of education and e-learning experts and business professionals from around the world committed to making difference. eLearning for Kids is actively seeking funding, volunteers, sponsors and courseware developers; get involved! For more information, please visit [www.e-learningforkids.org](http://www.e-learningforkids.org).

### 1.3 AC/AC CONVERTERS – CHANGERS

**Classification.** A switching converter that changes an ac supply to the ac supply with a different voltage, frequency, phase, or shape is called an *AC/AC converter* or *changer*. The first group of such converters unifies the *direct frequency converters* that change the frequency and ac voltage shape. Another group joins the *dc link frequency converters* where a rectifier is used as a voltage regulating or a constant-voltage front-end system whereas an inverter generates an ac voltage of certain frequency and magnitude.

**Cycloconverters.** *Cycloconverters* are the naturally commutated direct frequency converters that are synchronized by a supply line. Commonly, they are allowed in high-power applications up to tens of megawatts for frequency reduction. A thyristor closing by means of the natural commutation, i.e. turned off on zero current, is almost the only device that can meet the switch voltage and current rating needed at these power levels. 3-, 6-, 12-, and 24-pulse cycloconverters are used.

Cycloconverter topology can be subdivided into two types: direct single-step cycloconverters and indirect two-step cycloconverters.

Figure 20, *a*, shows the single-phase indirect cycloconverter. Its left and right sub-converters are the supply-side and the load-side controlled rectifiers, respectively, which may operate both in a rectifier mode and in an inverting mode. A reference signal, which drives the thyristor gates, specifies the frequency, the polarity, and the amplitude of the output voltage  $U_{s, load}$ . This means that the firing angles of the two sub-converters depend on this reference. As Fig. 20, *b, c, d* show, the output frequency amounts only to the part of the input frequency (the case when the fundamental output frequency is one-third of the input frequency is shown) while the firing angle changes between the minimum and the maximum possible values, depending on the reference magnitude. Particularly, in Fig. 20, *b*, the firing angle  $\alpha$  is of minimum value. The waveform of the output voltage at a reduced value of the reference is shown in Fig. 20, *c*. If the reference varies with time during each half-cycle instead of remaining constant, the firing angles change during the half-cycle also. This reduces the harmonic content in the output voltage, as Fig. 20, *d* shows.

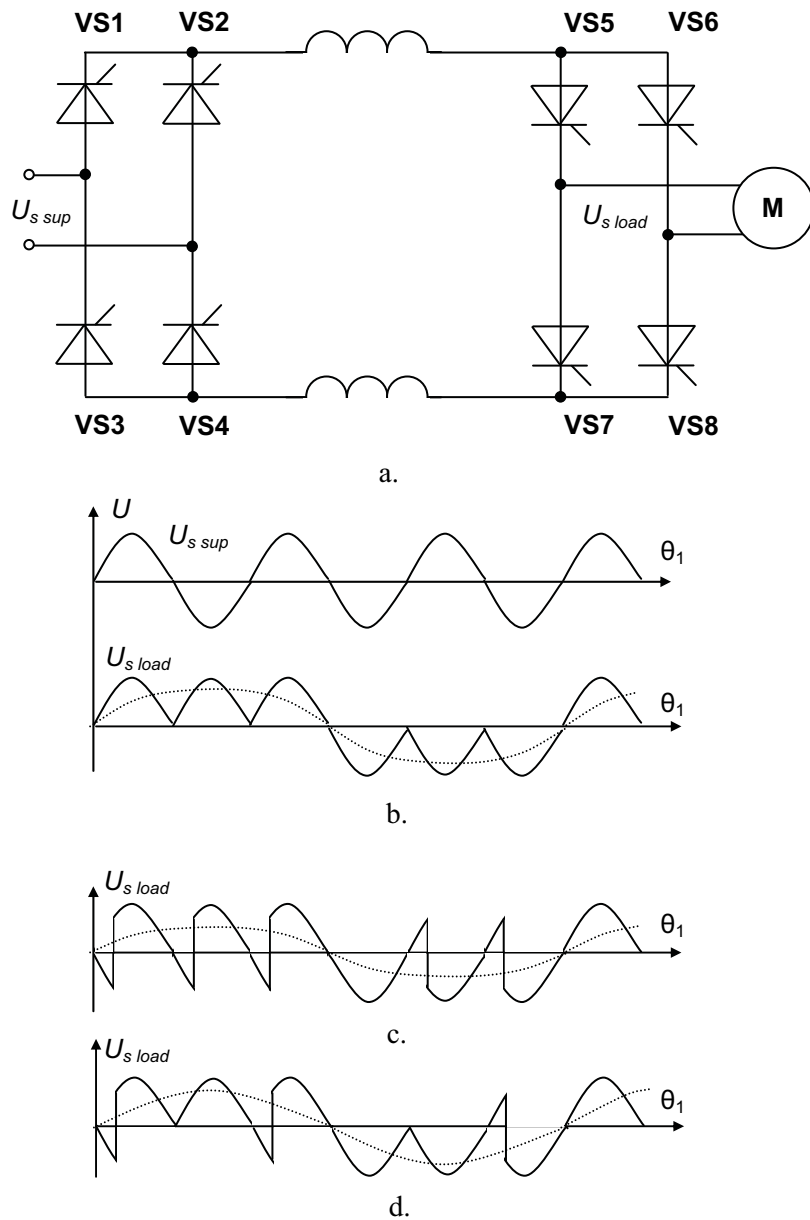

Fig. 20

The cycloconverter provides full four-quadrant operation. To obtain the positive voltage passing the positive current in the first quadrant of the current-voltage plane, switches **VS5** and **VS8** are kept open, **VS6** and **VS7** closed, while switches **VS1** with **VS4** and **VS2** with **VS3** rectifier voltage by adjusting the firing angles in the range 0 to 90°. To obtain the negative voltage passing the positive current in the fourth quadrant, switches **VS5** and **VS8** are still open but switches **VS1** with **VS4** and **VS2** with **VS3** go to the inverting operation by adjusting the firing angles in the range 90° to 180°. To insure the negative voltage passing the negative current in the third quadrant, switches **VS6** and **VS7** are open, **VS5** and **VS8** closed, while switches **VS1** with **VS4** and **VS2** with **VS3** rectifier voltage by adjusting the firing angles in the range 0 to 90°. To ensure the positive voltage passing



the negative current in the second quadrant, switches **VS6** and **VS7** are still open whereas switches **VS1** with **VS4** and **VS2** with **VS3** go to the inversion.

The circuit diagram of a 6-pulse indirect cycloconverter is represented in Fig. 21. The device has the three-phase input and the single-phase output and consists of two anti-parallel three-phase bridges. Thyristors are closed thanks to the natural voltage commutation. To obtain bilateral load current, a “negative” converter, which carries a negative current, is placed in parallel with the “positive” one. Such a combined circuit is known as a naturally commutated four-quadrant cycloconverter.

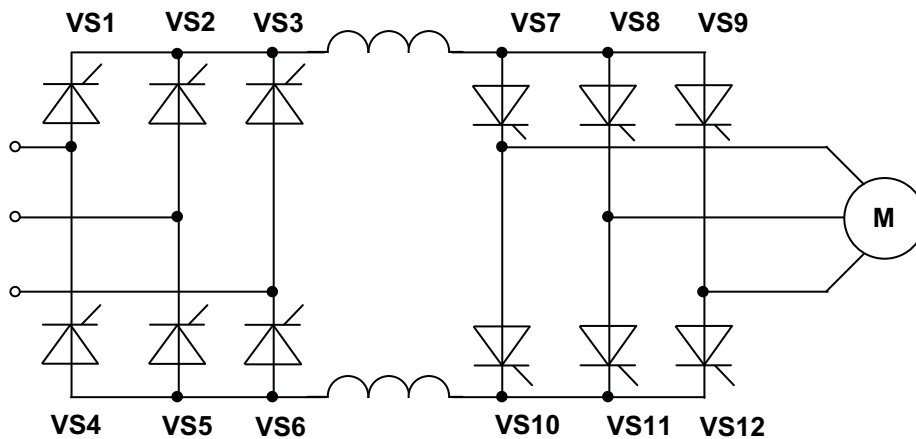

Fig. 21

.....Alcatel-Lucent 

[www.alcatel-lucent.com/careers](http://www.alcatel-lucent.com/careers)

What if you could build your future and create the future?

One generation's transformation is the next's status quo. In the near future, people may soon think it's strange that devices ever had to be "plugged in." To obtain that status, there needs to be "The Shift".





The converter produces an ac output voltage for the bi-directional output current. To obtain the positive voltage and pass the positive current in the first quadrant of the current-voltage plane, switches **VS1** and **VS6**, then **VS2** and **VS4**, and next **VS3** and **VS5** rectifier voltage by adjusting the firing angles in the rectifying range. To ensure the negative voltage passing the positive current in the fourth quadrant, the same switches go to the inverting operation by adjusting the firing angles in the inverting range. To pass the negative current, the two bridges change their roles so that **VS7...VS12** perform firing adjusting instead of **VS1...VS6**.

The firing angles are adjusted so that the output voltage is kept close to the sinusoidal form. For smooth commutation of the current from one bridge to another, the firing angle is momentarily changed above  $45^\circ$  and the bridge goes into the inverter operation mode.

Unfortunately, the frequency of the output voltage cannot precede the frequency of the supply voltage and is always at least twice less. Moreover, the large number of thyristors seems at first sight staggering. For the six-pulse converter with a three-phase output shown in Fig. 22, a minimum of 36 thyristors is required. This indicates that cycloconverters are mainly of interest for large systems, where parallel thyristor branches would be necessary in other converter circuits.

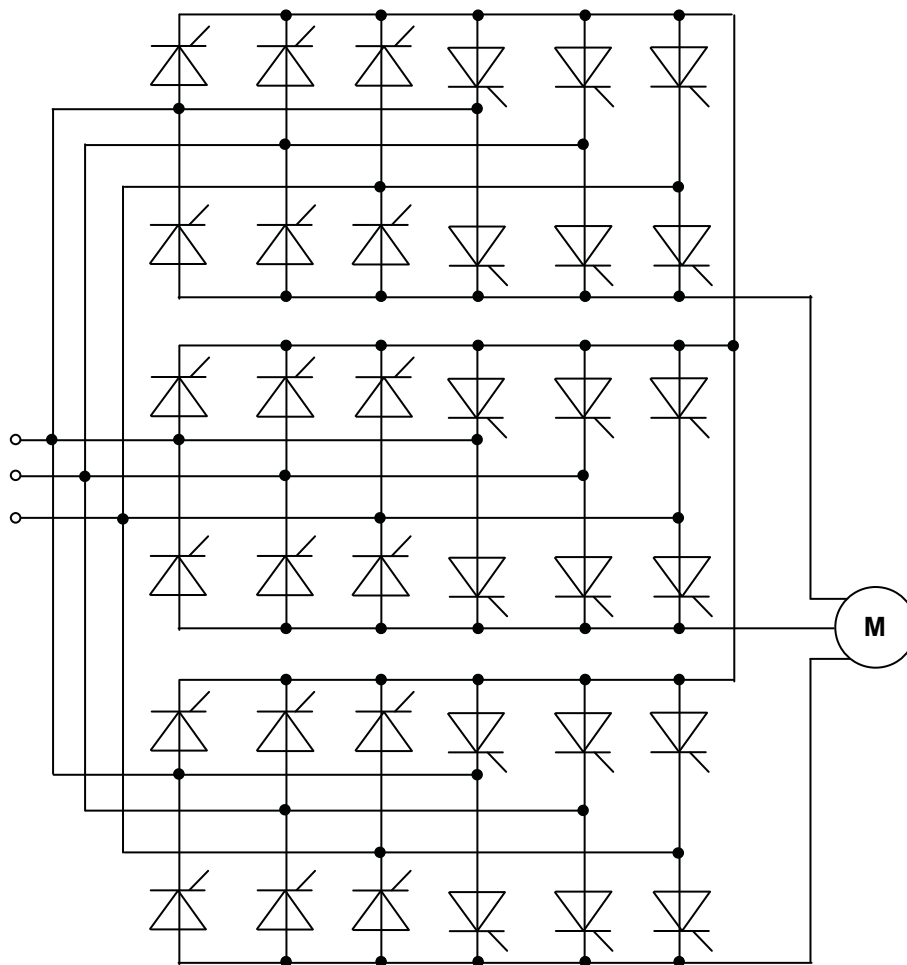

Fig. 22

One popular circuit of the direct frequency converter is given in Fig. 23. This three-phase cycloconverter incorporates three three-pulse midpoint dual controlled sub-converters that create three output voltages. Each sub-converter has six thyristors, three to carry the positive load current and three to carry the negative one. A transformer with a three-phase secondary winding is used for the thyristors supply. There is no difference whether the load is active or passive because operation in all four quadrants is possible.

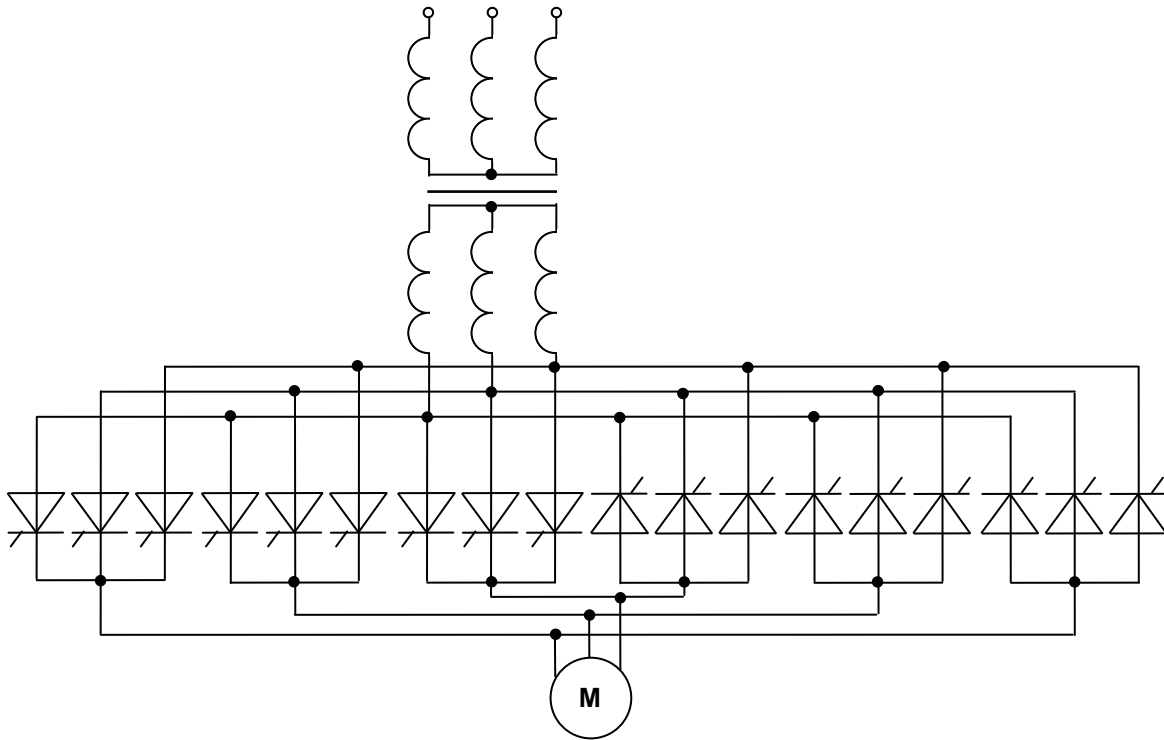

Fig. 23

Since the output voltages are assembled from the sections of the line voltages here, as the output frequency rises, the output voltages are tracking the sinusoidal references with increasing errors and consequent distortion. The frequency range

$$0 < f < \frac{mf_1}{15}$$

is usually considered as the useful range of operation, where  $f_1$  is the line frequency and  $m$  is the number of pulses. With a 50 Hz net and a three-phase circuit ( $m = 6$ ), this results in  $f_{\max} = 20$  Hz. Clearly, if a three-phase line of higher frequency is available, the range of output frequency is extended accordingly; this may be the case of vehicles or ships, when a diesel- or turbine-driven generator provides on-board power.

When considering the effects of a converter on the line-side currents, it is helpful to remember that a symmetrical three-phase system of sinusoidal voltages and currents results in constant

net power. Since the cycloconverter contains only switches but no storage devices (apart from the unavoidable leakage inductances, protective circuits, etc.), the total three-phase input power corresponds to the output power. Nevertheless, there will be reactive power on the line side, which is inherent in the control of the line-commutated converters by delayed firing.

**Matrix frequency converters.** Converters built on the bi-directional, bipolar switches are called *matrix converters*. Like the cycloconverters, they provide a direct power flowing between  $n$ -phase ac source and  $m$ -phase load. They are more compact, light, and versatile than other converter solutions. Matrix converters allow achieving higher levels of integration, broad output frequency and voltage range, higher temperature operation, and natural bi-directional power flow suitable to regenerate energy back to the utility.

Again, the matrix converter topology can be subdivided into two types: direct converters and indirect converters. The latter are also referred to as dual-bridge, sparse or two-stage matrix converters.

A generalized circuit diagram of a direct matrix converter with three-phase input  $U_{s\ sup}$  and three-phase output  $U_{s\ load}$  is shown in Fig. 24, *a*. Its power section consists of bi-directional, bipolar switches between each of the input and each of the output phases. In this crossbar arrangement, three load terminals are alternately connected to the three supply terminals. The maximum frequency is only constrained by the capabilities of semiconductor switches. However, the phase angle between the voltages and currents at the input can be controlled and does not have to be the same as at the output. In addition, the waveform and the frequency at the two sides are independent. Commutation strategies require that those switches – at least in certain time spans – be turned on only for one current direction, while maintaining blocking capability in the opposite sense.

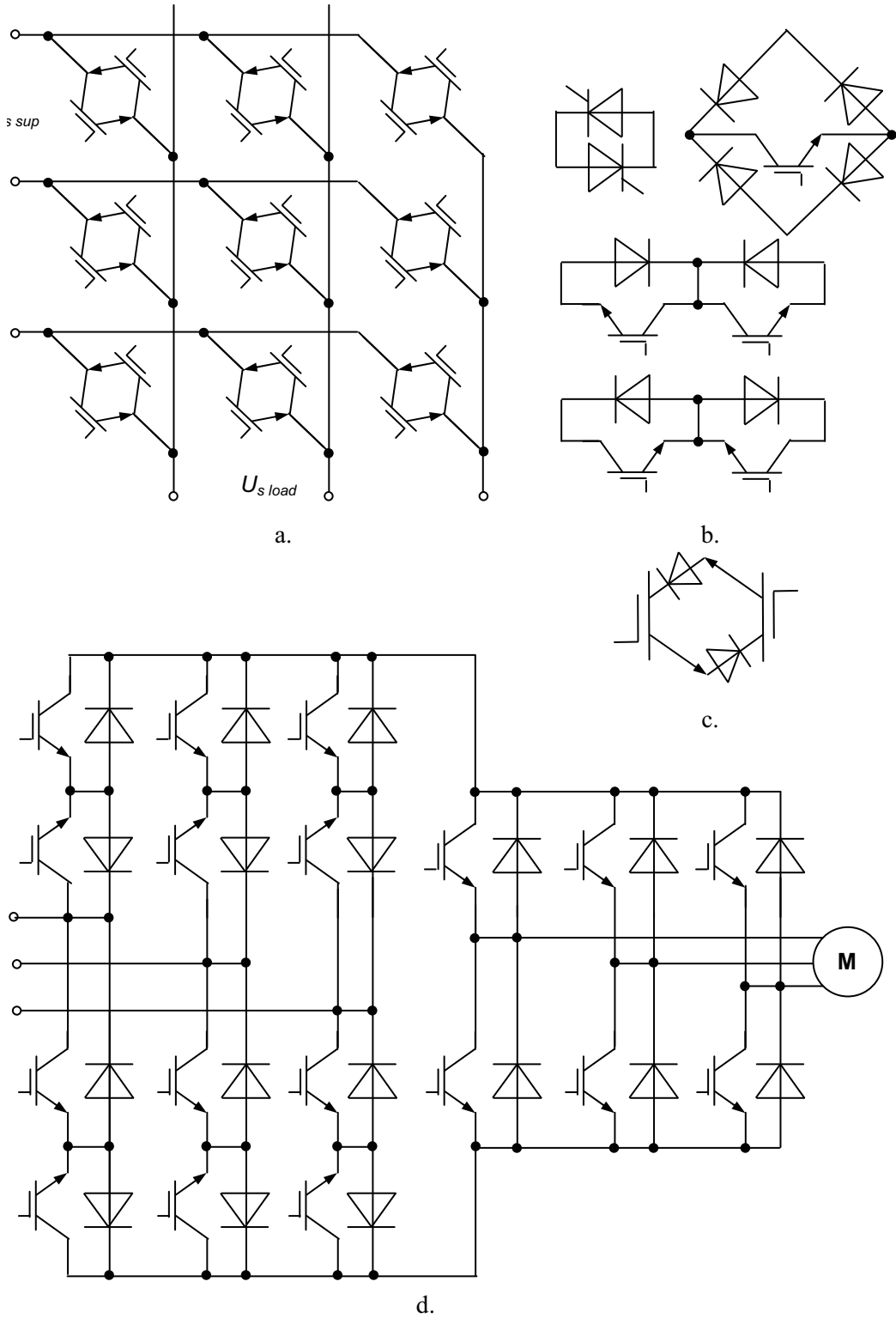

Fig. 24

The switches in a matrix converter must be bi-directional, that is, they must be able to block voltages of either polarity and to conduct current in either direction. This switching strategy permits the highest possible output voltage; at the same time, the reactive line-

side current is reduced since the current flows only in the center region of the line voltage periods. Typically, bidirectional, bipolar switches in a matrix converter operated at mains voltage levels are composed of a connection of two switching elements. These topologies permit separate control in both current directions. With this general arrangement of switches, the power flow through the converter is reversible. Because of the absence of any energy storage elements, the instantaneous power input may be equal to the power output, assuming idealized zero-loss switches. As far as this converter provides an output voltage directly from the multi-phase network voltage, the pieces of the input voltage conduct to the outputs at appropriate instants. That is why the output voltage of the required frequency, number of phases, phase, amplitude, etc. is generated and can be freely varied in a wide range.

The described matrix converter is simple in structure and has powerful controllability but the commutation problem and complex control keep it from being broadly utilized in industry. Theoretically, the switching sequence in the matrix converter must be instantaneous and simultaneous; unfortunately it is impossible for practical realization due to the turn-off IGBT characteristic, where the tailing-off of the collector current will create a short circuit with the next switch turn-on. This problem is typical for inductive load character that a motor has, therefore switching results in current and voltage spikes that may destroy the switches due to stress.



**Maastricht University**

*Leading in Learning!*

**Join the best at  
the Maastricht University  
School of Business and  
Economics!**

**Top master's programmes**

- 33<sup>rd</sup> place Financial Times worldwide ranking: MSc International Business
- 1<sup>st</sup> place: MSc International Business
- 1<sup>st</sup> place: MSc Financial Economics
- 2<sup>nd</sup> place: MSc Management of Learning
- 2<sup>nd</sup> place: MSc Economics
- 2<sup>nd</sup> place: MSc Econometrics and Operations Research
- 2<sup>nd</sup> place: MSc Global Supply Chain Management and Change

Sources: Keuzegids Master ranking 2013; Elsevier 'Beste Studies' ranking 2012; Financial Times Global Masters in Management ranking 2012

**Maastricht University is the best specialist university in the Netherlands (Elsevier)**

**Visit us and find out why we are the best!  
Master's Open Day: 22 February 2014**

[www.mastersopenday.nl](http://www.mastersopenday.nl)

These converters need a great number of bi-directional switches to connect input and output lines. As very fast bi-directional power switches are almost not available yet, they are realized by a combination of switches. Back-to-back connection of two IGBTs shown in Fig. 24, *a*, offers an independent control of the current in both directions and can be implemented using standard components available in a large range of current and voltage ratings. As practically these switches are implemented combining several unidirectional switches, a high number of power devices (diodes and transistors) are required. The interconnection of all these devices is a complex task due to high current and voltage spikes and overshoots produced by the power circuits, as well as the high number of control signals to be managed in a noisy environment. Reverse-blocking transistors are an emerging alternative with silicon in the current path. However, additional gate circuitry is required since the two emitters are not tied to the same potential.

Capacitive filters can remove the high frequency components of the line currents. There are also limits on the ratio of the input and output magnitudes. Any solution oriented to avoid these problems is welcomed by the design engineers. That is why different safe commutation strategies have been developed by many manufacturers to overcome the problem. A number of other building blocks were suggested, some of which are shown Fig. 24, *b*.

Sometimes, two anti-parallel connected thyristors can be used. Using a single transistor rounded by the bridge rectifier offers cost advantages with a simple control. However, a low-latency current detector is required by this circuit since the switch does not allow for natural turn-off. At higher frequencies, a switch built on fast IGBTs and freewheeling diodes should be used. These topologies permit separate control in both directions of the current flow. In the common collector configuration, only one power supply per input and output of the matrix topology is needed, however, separate drivers for IGBTs are required. In contrast, in a common emitter configuration, the drivers of each switch have to use an isolated supply; however, one driver for both IGBTs is sufficient if separate control of current direction is not required.

Another approach is to use the novel semiconductor device – reverse blocking IGBT. It behaves like an IGBT, but provides blocking capability for applied reverse voltage. An anti-parallel connection of two of those devices according to Fig. 24, *c*, operates as bi-directional, bipolar switch. Both directions of current flow can be controlled separately here. In a matrix converter, one driver would be needed for each reverse blocking IGBT, and one supply for the drivers of all devices connected with the emitter to the same input or output line.

Unlike the direct matrix converters, Fig. 24, *d*, proposes the sparse indirect matrix converter with the same functionality, but using separated input and output sections, connected by a dc link without storage elements. This design includes a four-quadrant current source rectifier

and a voltage source inverter. The input section consists of bi-directional bipolar switches, whereas the output section has a conventional bridge topology, as known from VSI. For a three-phase system operated at the mains voltage levels, it typically consists of three phase legs with two IGBTs with anti-parallel freewheeling diodes in both legs. A commutation strategy can be applied, changing the switching state of the input section while the output section is in a freewheeling mode. Thus, switching of the input section can be performed at zero current, which facilitates safe commutation and reduces switching losses to a minimum. Turn-on state of the bi-directional bipolar switches needs not be separately controllable for the two directions of the current flow. This commutation algorithm is of significantly less complexity and higher reliability as compared to a conventional direct matrix converter.

**DC link converters.** Converters with a dc voltage link circuit are the most common contemporary solution because of their wide area of applicability. They can be used for individual or multiple load applications in all fields of machine building and construction, mainly where the emphasis is on load-independent stability, maintenance-free operation, and high efficiency. Due to the characteristic of the impressed voltage in the dc link, the converters are stable in overload and no-load modes and can be disengaged from the load without damage. Usually, they come standard as 1-, 2- and 4-quadrant operation since the corresponding accessories are employed. A variable three-phase output voltage of such converters commonly rises up to the level of the input voltage and higher with a proportionally rising output frequency 0,1...10 to 120...400 Hz.

Figure 25 presents the frequency converter having a non-controlled mains rectifier, a dc link, and an inverter. The front-end rectifier **VD1...VD6** converts the three- or optionally also single-phase ac on the input terminals to a dc voltage, being proportional to the ac voltage in the order of magnitude of several hundreds of volts. This level is the reason why the following transistorized stages almost exclusively use IGBT or FET transistors with appropriate fast freewheeling diodes.

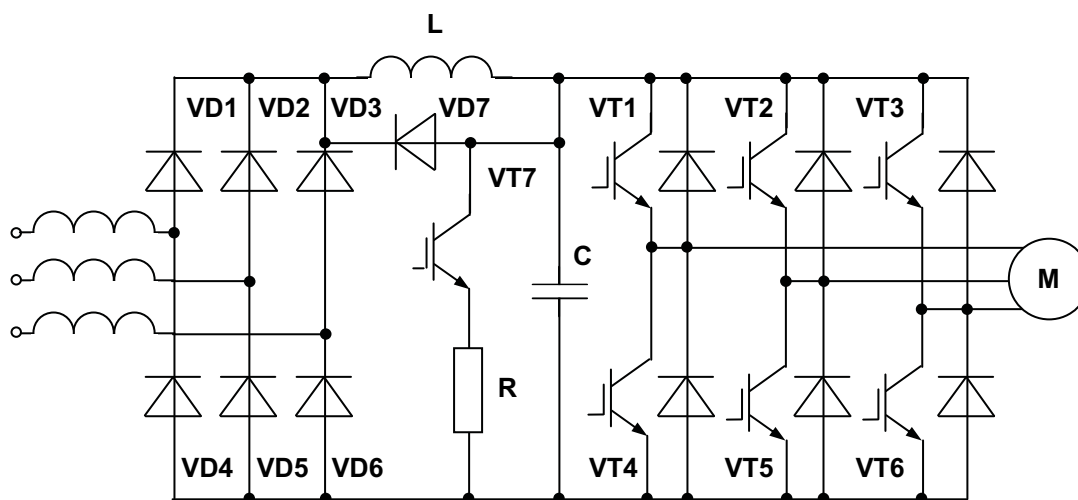

Fig. 25



Traditionally, the front-end bridge rectifier is connected to the supply line through the chokes or the transformer to defend the mains from the non-linear distortions of the converter. Between the front-end rectifier and the transistorized stage, an inductor (or choke)  $L$  may be inserted to protect and optimize the converter behavior. The ripple of the rectifier output voltage has a low value thanks to filtering by this smoothing inductor, which reduces the pulse spikes and limits the fault currents. Sometimes, the freewheeling diode  $VD7$  shunts the inductor to decrease its influence when the switches are off.

The large electrolytic compensative capacitor  $C$  protects the dc link from overvoltages. It “stiffs” the link voltage and provides a path for the rapidly changing currents drawn by the inverter. In some circuits, this capacitor is shunted by an additional  $RC$  circuit, which decreases the high-frequency obstacles. Once the converter is switched on, the capacitor charges. This way, the circuit startup current is limited. The capacitor permits the dc current to be temporary raised or lowered during commutation of the load-side inverter under the constant voltage.

Inverter switches  $VT1...VT6$  supply the load with the required ac voltages. By adjusting the transistor inverter circuit, the unidirectional link current and bi-directional voltage allows the use of a two-quadrant operation where the reverse power flow is achieved by the transistor control.



## Empowering People. Improving Business.

BI Norwegian Business School is one of Europe's largest business schools welcoming more than 20,000 students. Our programmes provide a stimulating and multi-cultural learning environment with an international outlook ultimately providing students with professional skills to meet the increasing needs of businesses.

BI offers four different two-year, full-time Master of Science (MSc) programmes that are taught entirely in English and have been designed to provide professional skills to meet the increasing need of businesses. The MSc programmes provide a stimulating and multi-cultural learning environment to give you the best platform to launch into your career.

- MSc in Business
- MSc in Financial Economics
- MSc in Strategic Marketing Management
- MSc in Leadership and Organisational Psychology

**BI NORWEGIAN BUSINESS SCHOOL**

EFMD **EQUIS** ACCREDITED

[www.bi.edu/master](http://www.bi.edu/master)

To provide the braking operation in the four-quadrant mode of the load, the inverter feeds recovered electrical energy to the dc link. For that, the feedback diodes across the transistors provide an alternate path for the inductive current when the switches are turned off. The diodes return the regenerating power to the dc link, which will raise the link voltage above its normal value and measures must be taken to absorb this regenerated power to prevent a dangerous link voltage buildup.

Typically, to prevent dc voltage from exceeding capacitive storage element ratings, the special *brake chopper* **VT7** connects a *braking resistor* **R** across the dc link capacitor **C** to absorb and dissipate energy. Usually, the brake chopper switches automatically on when the dc link voltage reaches a certain level.

Further, the shunts or the current transducers may be applied between the rectifier and the braking chopper or inverter as well as between the inverter and the load, depending on the concept of the control hardware. These sensors influence the transistors adjustment depending on the current value thus improving performance, safety, and cost.

Due to the diode front-end rectifier, the circuit has some disadvantages:

- the ac line current waveform is non-sinusoidal, therefore the high level of interference can penetrate to other equipment and disturb their normal operation
- the harmonic current distortion results in a distortion of the voltage and can affect the performance of other consumers connected to the power supply system
- such circuit cannot operate in the machines with frequent startups, braking, and current direction change

An active front-end rectifier can provide a solution for a majority of these problems. A converter with an active rectifier, shown in Fig. 26, can transfer energy in either direction, depending on the switching sequence. The circuit diagram of the rectifier is similar to that of an offline inverter, but it operates as a converter synchronized by the supply line. In the motoring mode, when the load acquires the supply power, the active rectifier passes the currents through the diodes whereas the inverter passes the currents through the transistors. In the braking mode, the inverter turns into the rectifier mode, passing the currents through the diodes, whereas the rectifier becomes an inverter and passes the currents through the transistors. Thus, the advantage of this circuit is that it allows a flexible bi-directional energy transition to and from the load back to the power supply line. A simple energy redirection results in implying the symmetrical circuit, adjusting the power factor to the unity or negative values, and supporting a wide range below and above the supply frequency. For correct operation, it usually requires some minimum value of inductance in the line to

avoid damage during switching. Line chokes may need to be added if a supply has high fault level and low-source impedance.

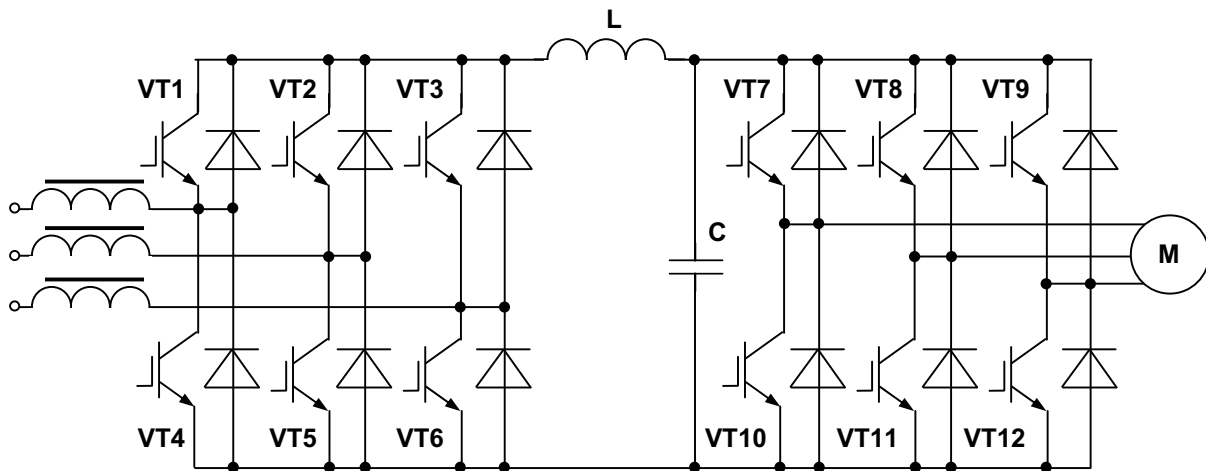

Fig. 26

**Summary.** Equipment that converts ac of one frequency to another frequency is known as a frequency changer. A cycloconverter is the most popular changer that permits direct transformation from ac to ac by appropriate switching and natural commutation of the control devices. Cycloconverters are used in high-power applications to decrease the supply frequency of such low-speed machines as rolling mills, hoists, excavators, and screw propellers. They do not contain energy storage in the intermediate circuit. Thanks to direct conversion of the input to the output power, they are very effective. The commonly used direct frequency converters are naturally commutated cycloconverters, but their disadvantages manage the low frequency output, which cannot be higher than 0,4 of the supply frequency. The power factor of the cycloconverters is low also.

Because of the absence of any energy storage elements, in the matrix converters the instantaneous power output approaches the power input, thus providing the highest efficiency. The application fed by a matrix converter is superior to other inverters because of the lack of the bulky reactive components with limited lifetime, the bi-directional power flow capability, the sinusoidal input and output currents, and adjustable input power factor. Furthermore, because of the high integration capability and the higher reliability of semiconductor structures, the matrix converter topology is recommended for extreme temperatures and critical volume/weight applications. In the motor drives, the braking resistors are not required, since the power flow during braking can be reverted, leading to a regenerative operation. However, a few of the practical matrix converters have been applied because the implementation of switch devices is sufficiently difficult and control technique is more complicated than with the conventional inverters. Converter nonlinearities, together with the sensor offsets, could

affect the estimation of the voltage applied to the load. Limited voltage transfer ratio and a high number of power semiconductor devices required restrict their usage.

Today, AC/AC converters with a dc link have the broadest use. The minimum power of such converters is measured by watts, whereas maximum may approach megawatts. The best models transfer energy in either direction, depending on the circuit arrangement and switching sequence. Nevertheless, sufficiently high level of their voltage distortion affects the performance of other equipment connected to the power supply system. Due to the use of an electrolytic capacitor between the two energy conversion stages, the design of the converter is bulky while efficiency is limited by the losses in series-connected electronic devices.

Whether ac power is supplied to an ac inductive load by a dc link conversion or by a direct ac conversion, the output voltage wave is not sinusoidal. This is the common drawback of all types of AC/AC converters.

## 1.4 DC/DC CONVERTERS – CHOPPERS

**Choppers.** Switching *DC/DC converters* are called *choppers*. As a rule, they provide changing and stabilizing of the output dc voltage.

Basic chopper topologies are *step-down* (*forward* or *buck*) and *step-up* (*flyback* or *boost*). Both of these may operate in single-quadrant, two-quadrant, and four-quadrant modes with or without the output feedback and output isolation. Converters with a feedback are known as *regulators*. A chopper consists of the switching circuitry and the filter section. In between the switching and filter sections, there may be a transformer for stepping up or down the voltage.

**Buck converter.** In the step-down forward chopper, the power switch **VT** is placed directly between the input voltage source  $U_{d\ sup}$  and the filter section (Fig. 27, *a*). The switch serves to replenish energy lost to the load during its off time. The shunt (flywheel) diode **VD**, series inductor **L**, and shunt capacitor **C** arrange an energy storage reservoir whose purpose is to save enough energy to maintain the load current over the entire off time of the switch.

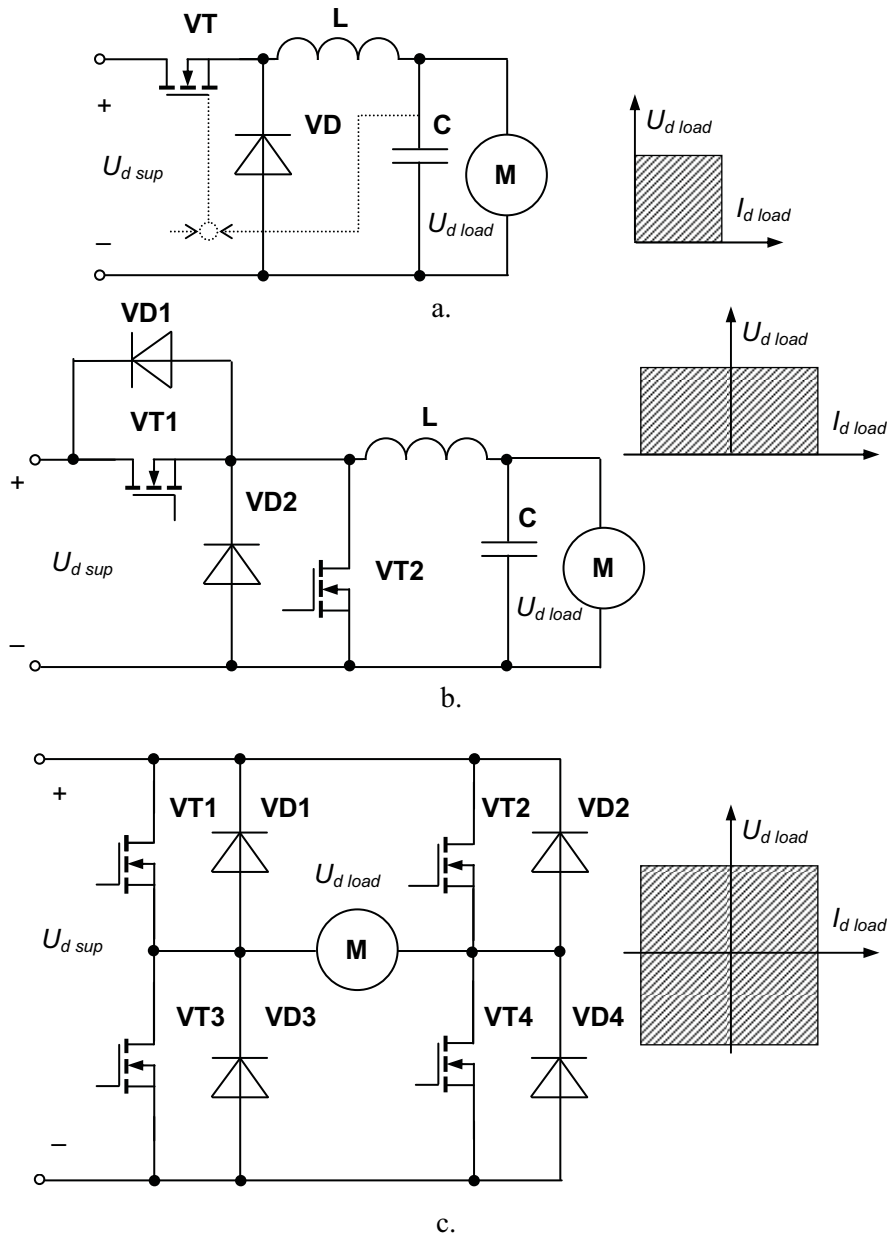

Fig. 27

Voltage applied to the load is a wave of varying periodicity. The graphs of the switch state and filtered load current  $I_{d\ load}$  and voltage  $U_{d\ load}$  for the forward converter are shown in Fig. 28, a. Converter operation can be broken up into two phases. The first phase is when the switch is on ( $t_{on}$ ). During this phase, the current passes from the input source through the inductor to the load and capacitor. The diode is reverse-biased. The inductor current rises according to the law:

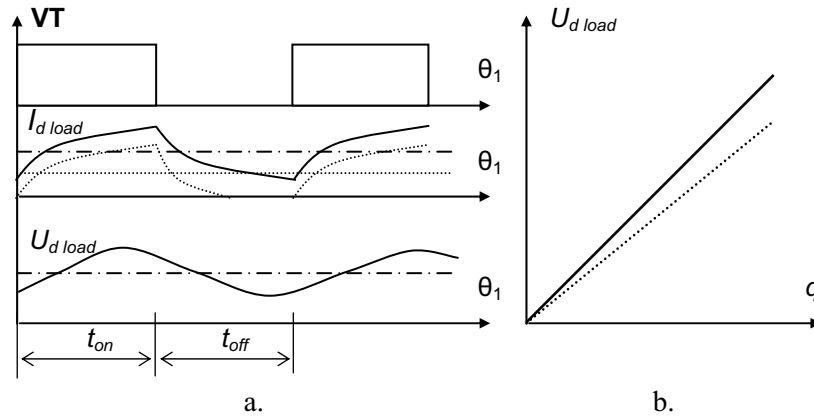

Fig. 28

$$\frac{dI}{dt} = \frac{U_{d\ sup} - U_{d\ load}}{L}$$

and once the switch turns off ( $t_{off}$ ), the inductor still expects current to flow through it. The diode now begins to conduct and the load current freewheels through the diode, thus maintaining a closed current loop through the load. Inductor current decreases as follows:

$$\frac{dI}{dt} = -\frac{U_{d\ load}}{L}$$

## Need help with your dissertation?

Get in-depth feedback & advice from experts in your topic area. Find out what you can do to improve the quality of your dissertation!

Get Help Now

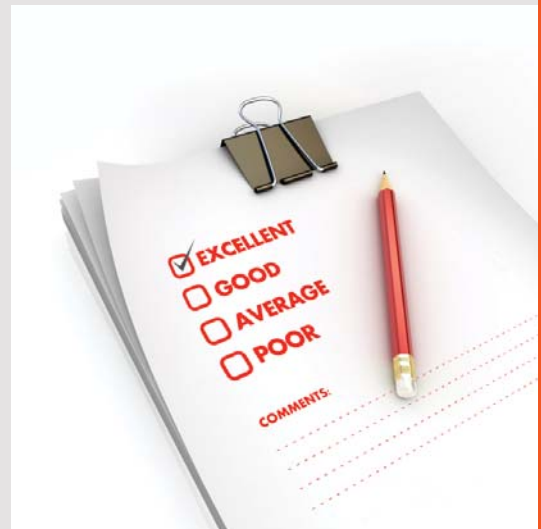

Go to [www.helpmyassignment.co.uk](http://www.helpmyassignment.co.uk) for more info



Then, the switch is turned on again and the cycle repeats. The chopping period of this circuit is

$$T_c = t_{on} + t_{off}$$

and the *chopping frequency*

$$f_c = \frac{1}{T_c}$$

Ideally, the *duty cycle (duty ratio)* is

$$q = \frac{t_{on}}{T_c}$$

The average and rms output voltage values are

$$U_{d\ load} = qU_{d\ sup}$$

$$U_{rms\ load} = \sqrt{q}U_{d\ sup}$$

From the *control curve* (Fig. 28, *b*) it is obvious that the output voltage grows linearly with the duty ratio of the chopper. In practice, the slope of the control curve depends on the current: the higher the current, the lower the curve slope, as the dotted line in Fig. 28, *b* shows.

This circuit supplies load by the unidirectional voltage and current providing the single-quadrant operation. The current may be continuous or discontinuous (dotted lines in Fig. 28, *a*). In the discontinuous current mode, the load voltage changes as follows:

$$U_{d\ load} = \frac{2U_{d\ sup}}{1 + \sqrt{1 + \frac{4k}{q^2}}}$$

where  $k = \frac{2L}{T_c R}$  and  $R$  is the motor winding resistance.

A *buck regulator* is a forward converter with a feedback. The voltage feedback shown in Fig. 27, *a*, by dotted lines adjusts the duty cycle to keep the output voltage at a desired level. A *sensing circuit* detects a change of the output voltage and adjusts the operation of the switching regulator. An increase in the loading caused by a decrease in load resistance



or mechanical torque on the motor shaft normally reduces the output voltage. As shown in Fig. 27, *a*, the converter output voltage measured by the voltage sensor is compared with its reference value using the comparator. The comparator output represents the switching function whose pulse width regulates the output of the converter.

A circuit that is capable of two-quadrant operation is depicted in Fig. 27, *b*. During the first phase, the converter operates as the basic chopper with **VT1** carrying the current. The current flows through the load while the transistor **VT1** is in on state. During the second phase, **VT1** is inoperative. Since the transistor **VT1** switches off, reactive energy of the load dissipates firstly through the freewheeling diode **VD2** and then via the discharge transistor **VT2**. **VT2** controls the current, which builds up negatively, limited by the load inductance. When **VT2** turns off, the only path for the current is via **VD1** back into the supply; hence, the circuit is regenerative.

Two-quadrant buck converter always supports the continuous current mode because the switches are capable of passing the current in both directions. Figure 27, *c* shows a basic four-quadrant *forward full-bridge converter* (filtered portion of the circuit is omitted here). The circuit diagram is the same as for the single-phase bridge inverter, thus the output voltage depends only on the control method. Ideally, here the average output voltage is

$$U_{d\ load} = (2q - 1)U_{d\ sup}$$

A variation of the full-bridge converter is the half-bridge converter where two split capacitors are placed instead of a pair of transistors. They form a dc input midpoint. It is sometimes used at slightly lower power levels compared to the full-bridge converter.

**Transformer-isolated converters.** In between the switch and the filter section there may be a three-winding transformer for stepping up or down the voltage, as shown in Fig. 29. Electrical isolation on the base of the transformer is required in the switch-mode dc power supplies for three reasons: safety (isolation of low-voltage dc output from the supply to avoid the shock hazard), different reference potential, and voltage matching (to avoid large voltage and current rating of semiconductor devices). The third winding in series with diode **VD1** as well as diode **VD2** serve for the core demagnetizing every switching cycle.

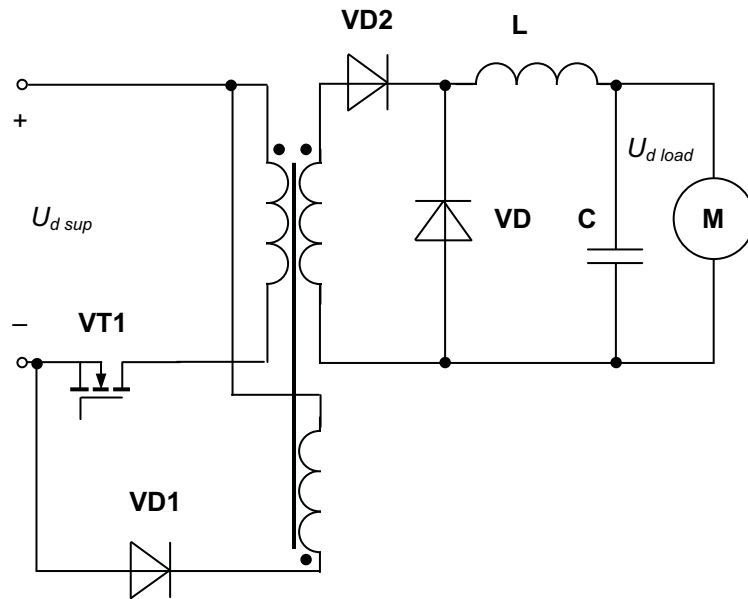

Fig. 29

The operation cycle of the forward *transformer-isolated converter* includes two phases: the working phase and the *loose running*. In the first phase the switch is on, the primary current flows through the switch, inducing the current into the secondary winding of the transformer.

# Brain power



By 2020, wind could provide one-tenth of our planet's electricity needs. Already today, SKF's innovative know-how is crucial to running a large proportion of the world's wind turbines.

Up to 25 % of the generating costs relate to maintenance. These can be reduced dramatically thanks to our systems for on-line condition monitoring and automatic lubrication. We help make it more economical to create cleaner, cheaper energy out of thin air.

By sharing our experience, expertise, and creativity, industries can boost performance beyond expectations. Therefore we need the best employees who can meet this challenge!

The Power of Knowledge Engineering

Plug into The Power of Knowledge Engineering.  
Visit us at [www.skf.com/knowledge](http://www.skf.com/knowledge)



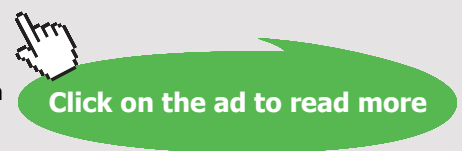

The secondary current charges the capacitor. In the second phase, when the switch is off, the diode is reverse-biased due to the self-induction of the transformer. Therefore, the load current occurs only because of the capacitor discharge.

Since the switch turns off, there is no full energy discharge of the transformer and the overvoltage may occur in the windings. To prevent the overvoltage, the additional winding with a diode is commonly used as mentioned above. The mass and weight of such a transformer will grow; it is the main drawback of the forward circuit. The amount of energy being delivered to the load is controlled by the duty cycle of the power switch on-time period. This may vary anywhere between 0 and 1 duty cycle and typically falls between 0,05 and 0,50 because the magnetizing and demagnetizing times are limited. For light loads, assume approximately

$$U_{d\ load} = qU_{d\ sup}$$

Single-switch buck converters are used in power ratings up to a few hundred watts. However, two-switch forward converters eliminate the need for a separate demagnetizing of winding. They are used in much higher power ratings of a kilowatt and more. Figure 30 shows the topology of the converter, where both transistors are gated on and off simultaneously. This *two-switch forward converter* is also known as *diagonal half-bridge forward converter*, *double-ended forward converter*, or *half-bridge asymmetrical forward converter*. This arrangement is particularly suitable for the MOSFET transistors, as the energy recovery diodes **VD1** and **VD2** provide preventing any overshoots during the flyback action. Its duty cycle cannot exceed 0,5 to avoid the isolated transformer saturation. During the first interval when both switches are on, diodes **VD1** and **VD2** get reverse-biased and the output inductor current flows through **VD3**, similar to that in a single-switch forward chopper. During the second interval when both switches are off, the magnetizing current in the transformer core flows through the two primary-side diodes, thus applying  $U_{d\ sup}$  negatively to the core and causing it to demagnetize. Application of  $-U_{d\ sup}$  to the primary winding causes **VD3** to be reverse-biased and the output inductor current flies back through **VD**.

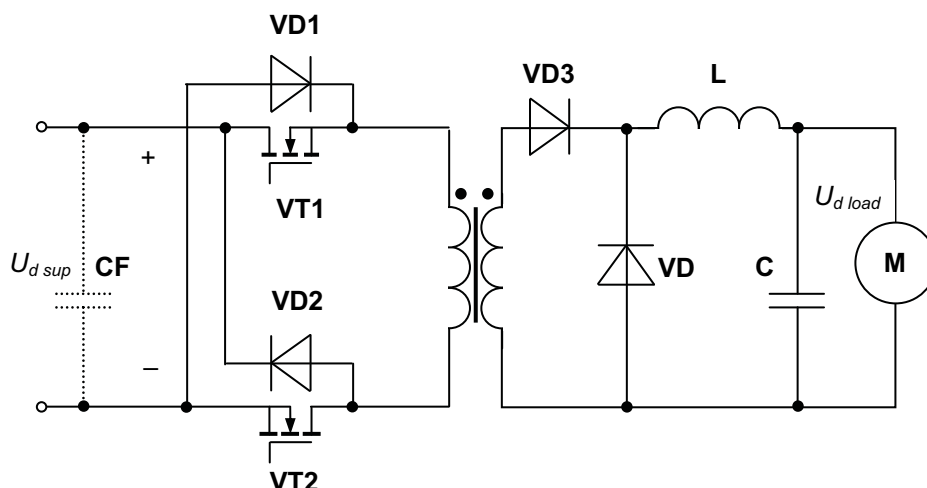

Fig. 30

The bridge transformer-isolated buck converters provide two-quadrant operation using the center-tapped transformer with the magnetic core. In Fig. 31, *a*, voltage applied to the primary winding alternates without a dc component. The waveform of this voltage has equal positive and negative volt-seconds, although the load voltage is always of a dc shape.

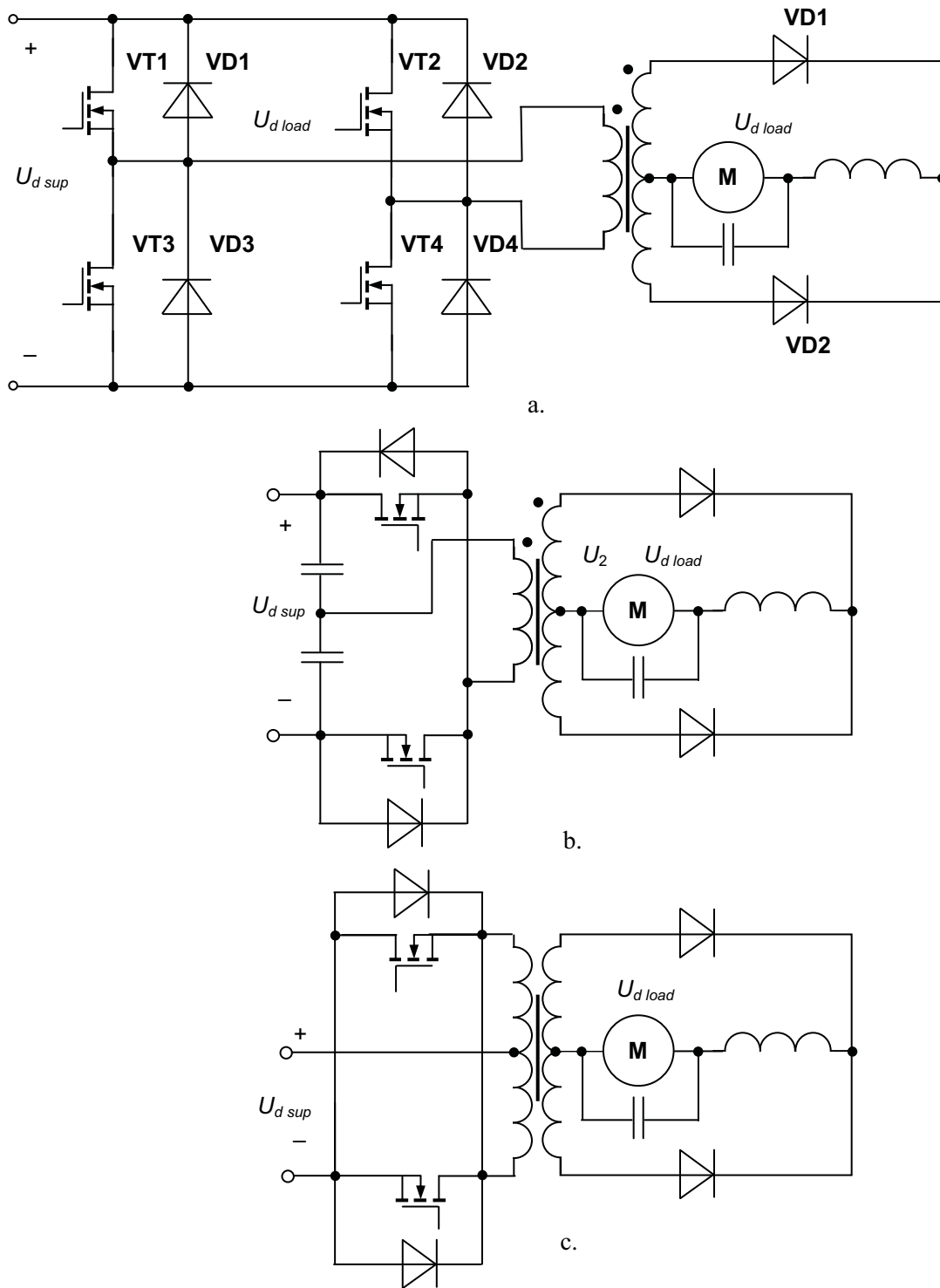

Fig.31

The midpoint converter shown in Fig. 31, *b*, consists of only two transistors but requires two split capacitors to form a dc input midpoint. It is sometimes used at slightly lower power levels compared to the full-bridge converter.

Push-pull principle of dc converting helps to build effective bi-directional circuits. The two-phase *push-pull converter* is shown in Fig. 31, *c*. The circuit includes the transformer with a center tap and the midpoint rectifier. During the first period, one switch is on and another is off. The current flows through the top diode and charges the capacitor. During the second period, the switches change their states. The current flows through the bottom diode and charges the capacitor again. In such a way, energy supplies the load both periods.

**Boost converters.** The step-down converters discussed above produce output voltages, the levels of which are less than the input voltage levels. However, the chopper configuration may be changed to provide higher load voltages. This operation is called *boosting*. A step-up flyback converter (Fig. 32, *a*) produces the higher output voltages than the input one. Here, inductor **L** is placed directly between input source  $U_{d\ sup}$  and switch **VT**. The anode of **VD** is in the node where the switch and inductor are connected, and capacitor **C** is connected across the load. Clearly, the step-up converter is similar to the reverse buck converter the input and the output of which changed their places. It causes the current regeneration by operation in the second quadrant of the current-voltage plane.



What do you want to do?

No matter what you want out of your future career, an employer with a broad range of operations in a load of countries will always be the ticket. Working within the Volvo Group means more than 100,000 friends and colleagues in more than 185 countries all over the world. We offer graduates great career opportunities – check out the Career section at our web site [www.volvogroup.com](http://www.volvogroup.com). We look forward to getting to know you!

**VOLVO**  
AB Volvo (publ)  
[www.volvogroup.com](http://www.volvogroup.com)

VOLVO TRUCKS | RENAULT TRUCKS | MACK TRUCKS | VOLVO BUSES | VOLVO CONSTRUCTION EQUIPMENT | VOLVO PENTA | VOLVO AERO | VOLVO IT  
VOLVO FINANCIAL SERVICES | VOLVO 3P | VOLVO POWERTRAIN | VOLVO PARTS | VOLVO TECHNOLOGY | VOLVO LOGISTICS | BUSINESS AREA ASIA

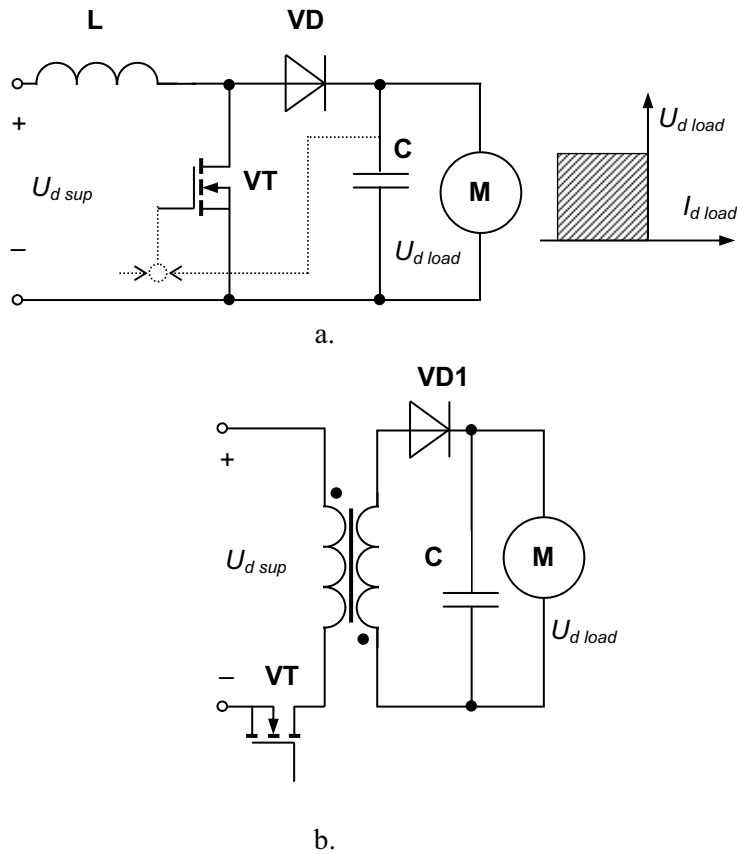

Fig. 32

As Fig. 33, *a*, explains, the boost operation consists of two periods. When the power switch is on, the current is being drawn through the inductor, which causes energy to be stored within its coil material. The switch then turns off. Since the current through the inductor cannot change direction instantaneously, it is forced to flow through the diode and the load and the inductor voltage reverses (flies back). This causes the diode to bias forward, thus dumping inductor energy into the capacitor. In this way, energy saved by inductor charges the capacitor, the voltage of which supplies the load. The inductor current decreases. This process continues until inductor energy is emptied. Since the inductor voltage flies back above the input voltage, the capacitor voltage becomes higher than the input voltage. When the capacitor voltage reaches the desired level, the switch turns on once again. The capacitor cannot discharge via the switch, as the diode is reverse-biased. Therefore, a stable voltage typically twice the  $U_{d\ sup}$  or more can be obtained.

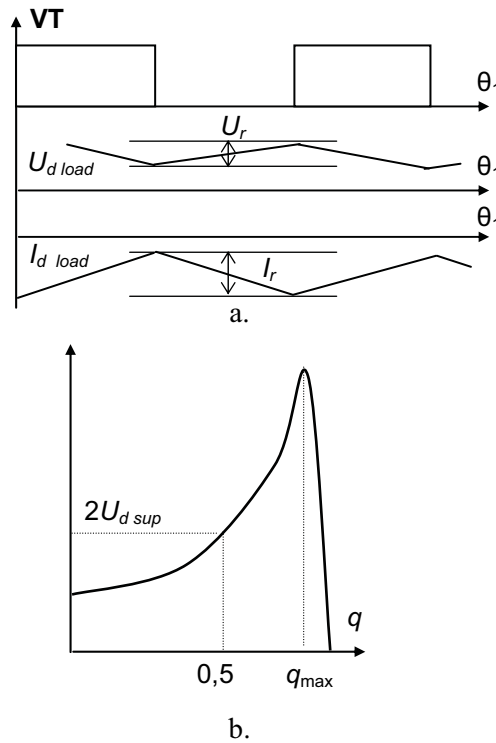

Fig. 33

Using the ideal duty ratio, the following formula describes the input and output voltages:

$$U_{d\ load} = \frac{U_{d\ sup}}{1 - q}$$

Thus, for a variation of  $q$  in the range  $0 < q < 1$ , the output voltage will be forced to change in the range of  $U_{d\ sup} < U_{d\ load} < \infty$ . In practice, the parasitic resistance  $\delta R$  of the circuit restricts the upper border of the control curve:

$$\delta R = R_1 + R_2 + R_3 + R_4,$$

where  $R_1$  is the inner resistance of the supply source,  $R_2$  is the resistance of the inductor,  $R_3$  is the resistance of the switched-on transistor, and  $R_4$  is the diode resistance. Because of this

$$q_{max} = 1 - \sqrt{\frac{\delta R}{R}} < 0,8 \dots 0,9,$$

where  $R$  is the load resistance. The appropriate control curves in Fig. 33, *b*, show the transistor behavior, the load voltage  $U_{d\ load}$  and the current  $I_{d\ load}$  having appropriate ripples  $U_r$  and  $I_r$ .



Again, current may be continuous or discontinuous. In the discontinuous current mode of operation

$$U_{d\ load} = U_{d\ sup} \left( 0,5 + \sqrt{0,25 + \frac{q^2}{k}} \right),$$

where  $k = \frac{2L}{RT_c}$ .

The boost DC/DC converter is recommended as an output stage of the passive single-phase rectifiers to perform their power factor correction in accordance with contemporary EMC standards. Thanks to this stage, the waveforms of the rectifier input voltage and current become strongly sinusoidal without phase shift between them, thus approaching the unity power factor. At the same time, the output voltage may be changed in a broad range, depending on the application needs.

A *boost regulator* is the flyback regulator with a negative voltage feedback shown in Fig. 32, *a* by dotted lines. It allows supporting the constant output voltage independent of the supply voltage and load variations. Such topology is used in supplies, active filters, and compensators of reactive power. The ability of the boost regulator to correct transients, spikes, and drops within the supply is quite important.

**qaiteye**<sup>®</sup>  
Challenge the way we run

**EXPERIENCE THE POWER OF FULL ENGAGEMENT...**

.....

**RUN FASTER.  
RUN LONGER..  
RUN EASIER...**

READ MORE & PRE-ORDER TODAY  
[WWW.GAITEYE.COM](http://WWW.GAITEYE.COM)

In the transformer-isolated converter shown in Fig. 32, *b*, during the first phase, while the switch is on, the primary winding stores energy and the primary current is growing up. Once the switch turns off, the polarity of the windings changes due to the self-induction phenomenon. The diode biases forward, the secondary current charges the capacitor, and the primary current falls. There is no high overvoltage in this case. The load current may be continuous or discontinuous but the supply current flows continuously anyway.

**Buck-boost converters.** A chopper, which generates the load voltages of less or higher levels than the supply voltage (*buck-boost converter*) is shown in Fig. 34, *a*. Like in the step-down chopper, the power switch **VT** is placed here directly between the input voltage source  $U_{d\ sup}$  and the filter section. Diode **VD**, series inductor **L**, and shunt capacitor **C** compose an energy storage reservoir. When the switch is on, the inductor is connected to the supply voltage and the inductor current increases. While the switch is off, the inductor voltage changes the polarity and the inductor current decreases flowing through the load and diode.

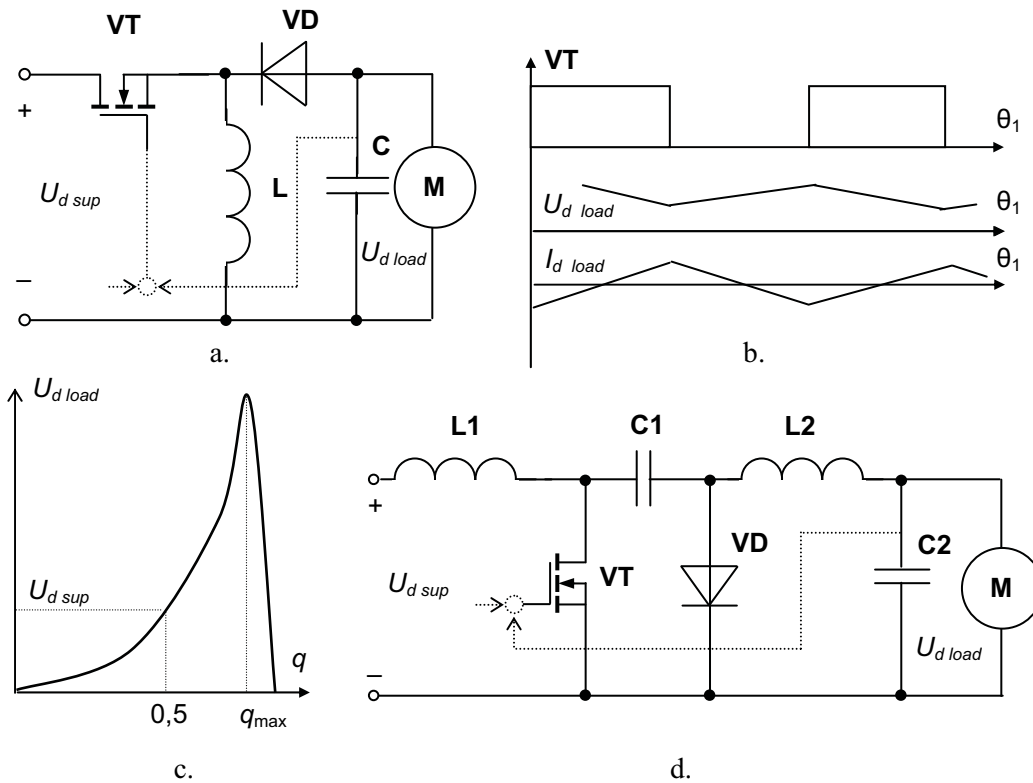

Fig. 34

Fig. 34, *b* shows the output voltage and current waveforms. In this converter

$$U_{d\ load} = U_{d\ sup} \frac{q}{1-q}$$

Here, for a variation of  $q$  in the range  $0 < q < 1$ , the output voltage may theoretically be changed in the range  $0 < U_{d\ load} < \infty$ . Again, in practice inequality occurs:  $q < q_{\max}$ . In the real converter, the loss resistance  $5R$  is to be taken into account (Fig. 34, *c*):

$$U_{d\ load} = U_{d\ sup} \frac{q}{(1-q) \cdot \left(1 - q^2 + \frac{\delta R}{R}\right)}$$

The current may flow continuously or to be interruptible. In the last case

$$U_{d\ load} = U_{d\ sup} \frac{q}{\sqrt{k}},$$

where  $k = \frac{2L}{RT_c}$ .

A *buck-boost regulator* is a form of the buck-boost chopper with the negative voltage feedback, whose operation is very closely related to the buck and boost regulators.

The *Cuk converter* named after its inventor is shown in Fig. 34, *d*. Similar to the usual buck-boost converter, the Cuk converter provides the negative output signal with respect to the common terminal of the input voltage. Here, capacitor **C1** acts as the primary unit of the energy storing and transferring from the input to the output. In a steady state, inductor voltages are zero. Therefore

$$U_{C1} > U_{d\ sup}$$

$$U_{C1} > U_{d\ load}$$

When the switch is off, inductor currents flow through diode **VD**. Current  $I_{L1}$  is decreased because  $U_{C1} > U_{d\ sup}$ . The energy stored in **L2** feeds the output. Therefore,  $I_{L2}$  also falls. When the switch is on,  $U_{C1}$  reverse biases the diode. Currents  $I_{L1}$  and  $I_{L2}$  flow through switch **VT**. Capacitor **C1** discharges through the switch and  $I_{L2}$  increases. The input power feeds energy to **L1** causing  $I_{L1}$  to grow. Equating input and output powers in this converter leads to the equation:

$$U_{d\ load} = U_{d\ sup} \frac{q}{1-q}$$

which shows the same functionality as the step-down and step-up chopper. One of the advantages of the Cuk converter is that this circuit produces continuous current without

any additional filters. Its uninterrupted output current reduces the required capacity of the output capacitor.

**Soft switching converters.** In the hard switching converters discussed above, the switching power losses, device stresses, high thermal effects, and electromagnetic interference resulting from high current and voltage spikes occur regularly. Unlike typical resonant converters, new soft-switched converters usually utilize resonance in a controlled manner. Resonance is allowed to occur just before and during the turn-on and turn-off processes to create ZVS and ZCS conditions.

The fundamental component used in a soft-switching technique is a resonant switch. It is a sub-circuit comprising a semiconductor switch and resonant elements **L** and **C**. In a ZCS, an inductor is connected in series with a power switch. The objective of this type of switch is to shape the switch current waveform during the transistor turn-off whereas at turn-on the switch current rises slowly from zero. It will then oscillate because of the resonance between **L** and **C**. In a ZVS, a capacitor **C** is connected in parallel with the switch. The objective of this type of switch is to create a zero-voltage condition for the switch turn-on.

This e-book  
*is made with*  
**SetaPDF**



PDF components for PHP developers

[www.setasign.com](http://www.setasign.com)



To archive switching under zero voltage (ZVS), a buck converter may be modified, as shown in Fig. 35, *a*, by adding small external capacitors. The inductance value in this case is chosen to be much smaller than in a buck converter such that the inductor current has a waveform with a high ripple, thus the transition from one transistor to another occurs at zero voltage.

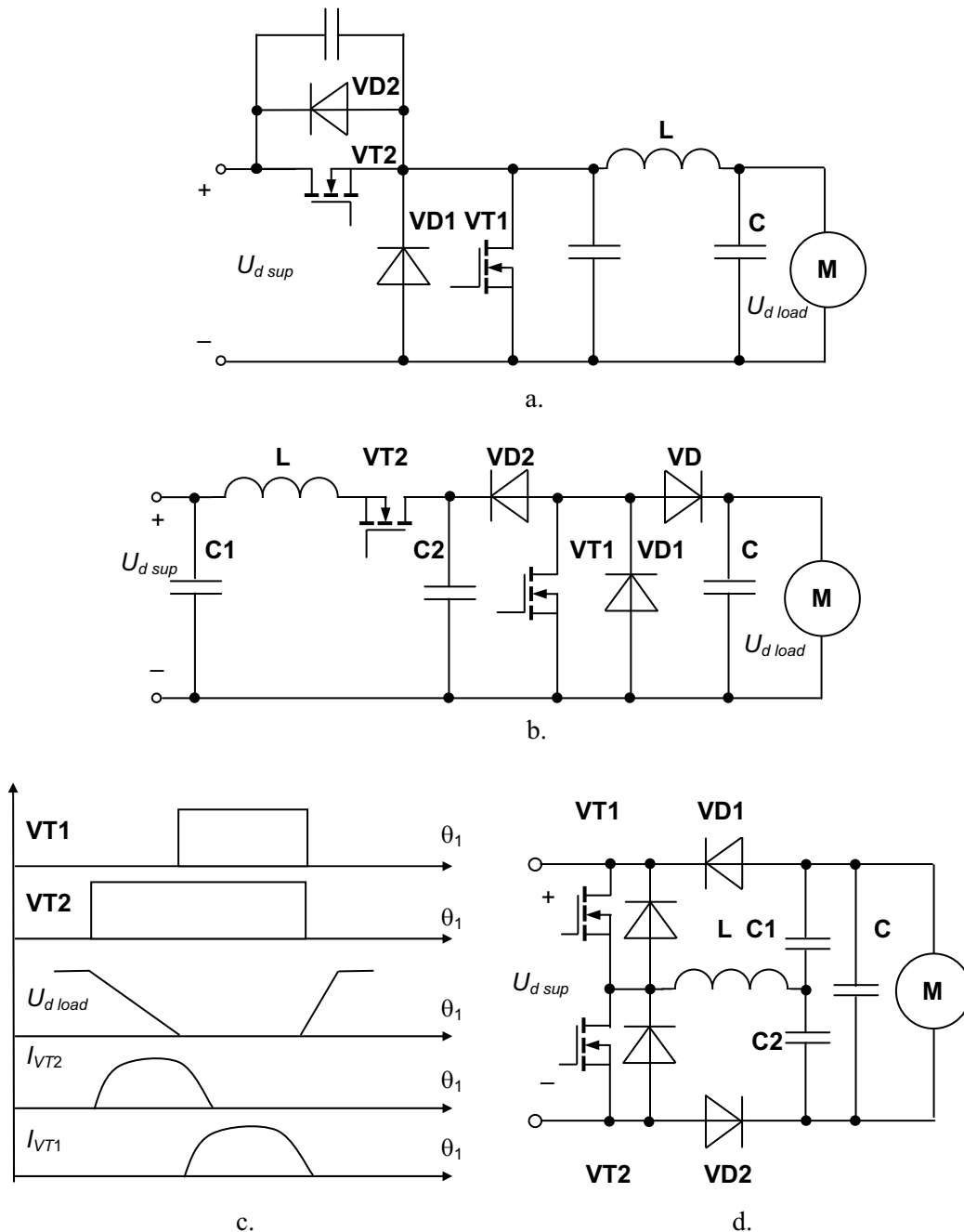

Fig. 35

As an example of a new energy technology, the snubber-assisted zero-voltage and zero-current transition buck chopper (SAZZ) is shown in Fig. 35, *b*. This configuration realizes the

desirable properties of zero-current turn-off and zero-voltage turn-on. Figure 35, *c* illustrates voltage and current waveforms of the SAZZ. Firstly, the snubbed capacitor **C2** discharges through the auxiliary switch **VT2** causing zero voltage and zero current in the main switch **VT1** by a resonant reverse current of **VT2**. When the switch **VT1** turns off, voltage across **VT1** starts to increase from zero because of capacitor **C2** charging.

The soft switching boost converter is shown in Fig. 35, *d*. In the figure, **VT1** and **VT2** are the main switches. Diodes **VD1** and **VD2** prevent reverse current from the motor to the power supply. The small-size capacitors **C1** and **C2** provide a resonance with an inductor **L**. The load voltage is smoothed by the large capacitor **C**. Switches **VT1** and **VT2** turn on or off alternately by the gate signal. When one switch is in on state, the other is in off state. Consequently, the resonant current flows through the on-state switch (for example **VT1**), then via the inductor, capacitor **C1**, and returns back through diode **VD1**. At the beginning, **C2** is at low voltage, therefore the resonant current increases in the inductor. On the other hand, because of high voltage of **C1** due to the former operation, it discharges forward through the motor. In such a way, the boosted voltage can be obtained on the output side. By the commutation of **C1** and **C2**, the output voltage can be given about two times of the input voltage.

Since switching is performed at zero current, switching losses are low. Accordingly, the soft switching converter has a significant advantage to increase the whole circuit efficiency. In addition, since the switch charge and discharge in resonance are efficiently available due to alternate operation, it is clear that utilization efficiency for the reactive components is high.

**Summary.** One embodiment of a DC/DC converter is known as a chopper. The chopping circuits normally operate at the frequencies of 2...200 kHz. The main features of the step-down choppers are: very high current and voltage rising and decreasing during transients that lead to high dynamic power losses. Industrial applications of these circuits are normally restricted to loads below 5 kW. Traction applications, however, are designed at ratings of hundreds of kilowatts.

The DC/DC converters, which produce the voltage higher than supply voltage, must accumulate energy in the input reactive element (inductor) and pass it into the output reactive element (capacitor) independently, in different time intervals. The control of these processes is provided by means of duty cycle changing with or without feedback.

The universal DC/DC converters step up and step down the load voltage, support single-, two- and four-quadrant operation, and do not require additional filters and powerful reactive elements. The fast switching devices are the necessary components of such circuits. Nevertheless, these converters suffer from several additional stresses. Therefore, their implementation is beneficial only when both the buck and the boost capabilities are needed. Otherwise, a step-down or a step-up converter should be used based on the desired capability.

## 2 POWER ELECTRONIC CONTROLS

Power electronic converters must be suitably controlled to supply the voltages, currents, or frequency ranges needed for the load and to guarantee the requested power quality. The process of the power converter control and adjustment is called *gating*. Gating procedures involve switching the power converter on and off, adjustment its necessary mode of operation, control the performance accordantly the reference, protection in danger, and examination its operation with the required diagnostic.

Different gate circuits provide gating by the control of the thyristor and transistor switching instants. Usually, they perform the following operations:

- clocking the discrete intervals for the system timing
- generation of carrier signals
- production of control pulses
- conversion of the control pulses into the gate pulses
- distribution of the gate pulses between the power switches
- galvanic isolation of control and power circuits



www.sylvania.com

We do not reinvent  
the wheel we reinvent  
light.

Fascinating lighting offers an infinite spectrum of possibilities: Innovative technologies and new markets provide both opportunities and challenges. An environment in which your expertise is in high demand. Enjoy the supportive working atmosphere within our global group and benefit from international career paths. Implement sustainable ideas in close cooperation with other specialists and contribute to influencing our future. Come and join us in reinventing light every day.

Light is OSRAM

OSRAM  
SYLVANIA





An ordinary *gate driver* (Fig. 37) compares the *reference signal*  $u^*$  with a periodic *carrier signal*  $u_c$  of the *carrier generator*, synchronized by the supply voltage  $U_s$ . Whenever the difference of the compared signals becomes positive for the first time in each half-period, the gate driver performs control pulses and allocates them between the pulse *amplifiers* of the converter power switches. Many manufacturers of electronic devices supply gate circuits available on computer boards.

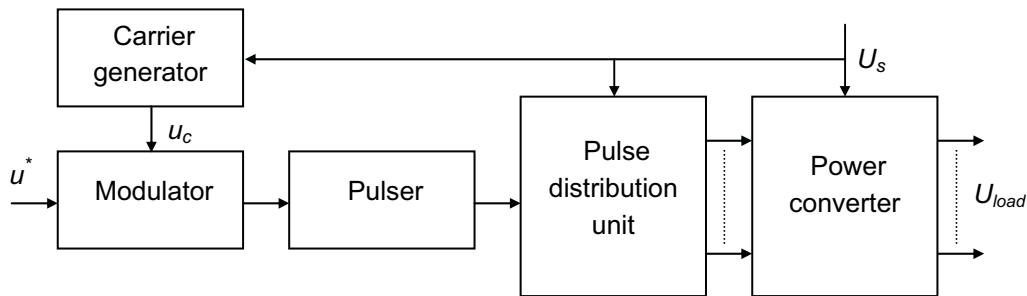

Fig. 37

Gating restrictions concern the maximum and minimum peak and duration of the gate pulses. In order to allow a safe turn-on commutation, the gate pulse should be high enough to avoid an unwanted turn-off immediately after the turn-on. To stabilize the output signal by keeping the output voltage at a desired level, a negative *feedback* is used sometimes.

Perhaps, the most important process for implementing control in power converters is *modulation* that is the power switching adjustment in accordance with the reference signal. To realize gating functionality, multiple modulation techniques are used.

In the thyristor converters, the *phase modulation* method is used commonly. The simplest *block modulation* has been outlined along with the transistor converter description: the *square-wave* or *rectangle modulation* method.

## 2.1 PHASE MODULATION

**Operation diagram.** An *operation diagram* called also *timing diagram* of the gate circuit for the three-phase bridge rectifier given in Fig. 4, f displays the gating process in Fig. 38. At those very instants when the supply voltages  $U_{L1}$ ,  $U_{L2}$ ,  $U_{L3}$  cross the zero level, the carrier signal  $u_c$  is generated. Carrier pulses may be different but their period is exactly divisible by the supply voltage period. The other entry of the gate driver is the reference *modulation signal*  $u^*$ . The amplitudes of both signals – reference and carrier – are scaled in such a way that their extremes  $U_{\max}$  are equal to each other. Whenever their difference becomes positive for the first time in each half-period ( $u^* > u_c$ ), the gate driver produces a short pulse  $I_G$ ,

which, after amplification by the pulse amplifier, passes through an isolating circuit to the gate of an appropriate thyristor to be fired. To start the next half-wave and to provide the discontinuous current mode, pulses must be sufficiently broad or doubled. Such paired pulses are shown in Fig. 38.

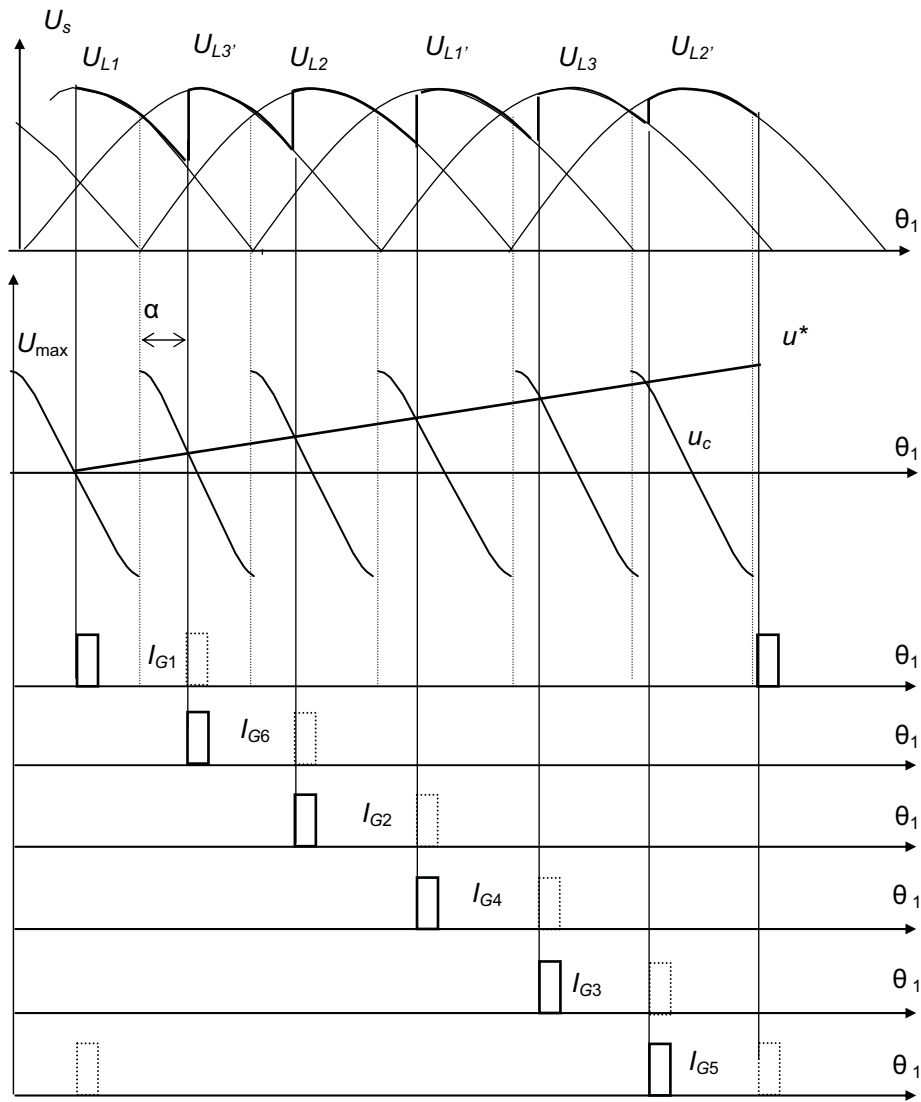

Fig. 38

It is seen that the comparison of the reference signal  $u^*$  with the carrier signal  $u_c$  represents a *sampling method* that provides a voltage-to-phase conversion with phase modulation. Often, the carrier signal  $u_c$  is a saw-tooth function or, instead of a saw-tooth, alternations of cosine wave are employed:

$$u_c(\theta_1) = U_{\max} \cos \theta_1$$

$$\alpha = \arccos \frac{u^*}{U_{\max}}$$

Here, the supply voltage phase  $\theta_1$  is calculated in the range from 0 to  $\pi$  from the carrier  $u_c$  starting point, which is at the same time the natural commutation point of the firing thyristor and  $U_{\max} = \max(u_c, u^*)$ . A similar effect is sometimes achieved by inserting an arcsine wave generator in the input channel of the firing circuit.

**Control curves.** The single-phase rectifiers shown above in Fig. 4, *b*, *c*, *d* drive the resistive load with the discontinuous current. Their rectified load voltage depends on the firing angle  $\alpha$ , as the *control curve* in Fig. 39, *a* shows:

$$U_d = \frac{U_0}{2}(1 + \cos \alpha)$$

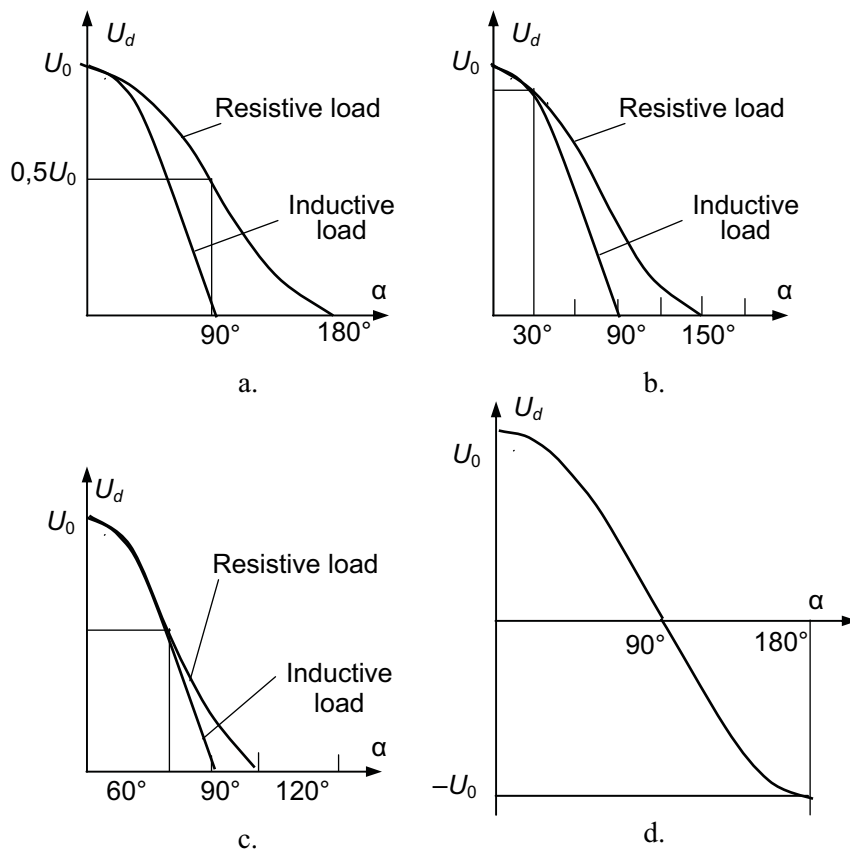

Fig. 39

In the half-wave circuit shown in Fig. 4, *b*, the average value of the dc output alternation that a dc voltmeter reads in a non-controlled rectifier is equal to

$$U_0 = \frac{\sqrt{2}U_s}{\pi} = \frac{U_s}{k_U} = \frac{U_s}{2,22}$$

In the single-phase full-wave rectifier shown in Fig. 4, *c*, and in the single-phase bridge rectifier shown in Fig. 4, *d*,

$$U_0 = \frac{2\sqrt{2}U_s}{\pi} = \frac{U_s}{k_U} = \frac{U_s}{1,11}$$

When the resistive-inductive load with infinite inductance is adjusted,

$$U_d = U_0 \cos \alpha \quad (1)$$

with  $U_0 = 0,9U_s$  and *continuous current* flowing via the load in all single-phase circuits. The corresponding control curve is shown in Fig. 39, *a* also. In between the two control curves, the discontinuous current area lies.

In the three-phase full-wave rectifier (Fig. 4, *e*) in the interval  $\alpha = 0 \dots 30^\circ$ , the continuous current flows through the resistive and inductive loads. The average value of the dc output voltage does not depend on the type of load and is measured by (1) again, where

$$U_0 = \frac{3\sqrt{6}U_s}{2\pi} = \frac{U_s}{k_U} = \frac{U_s}{0,85}$$



Discover the truth at [www.deloitte.ca/careers](http://www.deloitte.ca/careers)

**Deloitte.**

© Deloitte & Touche LLP and affiliated entities.

The appropriate part of the control curve is shown in Fig. 39, *b*. In between  $30^\circ$  and  $90^\circ$ , the continuous current flows through the resistive-inductive load with infinite inductance and the control curve keeps its previous shape (1).

In the case of resistive load, the current becomes discontinuous in the region between  $30^\circ$  and  $150^\circ$ , and the control curve equation is converted into the formula:

$$U_d = \frac{U_0}{\sqrt{3}} \left( 1 + \cos \left( \frac{\pi}{6} + \alpha \right) \right),$$

where

$$\frac{U_0}{\sqrt{3}} = \frac{3\sqrt{2}U_s}{2\pi} = 0,67U_s$$

The corresponding control curve is shown in Fig. 39, *b* also.

In the three-phase bridge rectifier shown in Fig. 4, *f*, when  $0 \leq \alpha \leq 60^\circ$ , the continuous current flows through the resistive and inductive loads. The average value of the dc output voltage is again calculated by (1), where

$$U_0 = \frac{3\sqrt{6}U_s}{\pi} = \frac{U_s}{k_U} = 0,42$$

The corresponding control curve is shown in Fig. 39, *c*. In between  $60^\circ$  and  $90^\circ$ , the continuous current flows through the resistive-inductive load with infinite inductance and the control curve keeps its previous shape (1).

In the case of resistive load, the current becomes discontinuous in the region from  $60^\circ$  to  $120^\circ$ , and the control curve equation describes

$$U_d = U_0 \left( 1 + \cos \left( \frac{\pi}{3} + \alpha \right) \right)$$

with  $U_0 = 2,34U_s$ . The corresponding control curve is shown in Fig. 39, *c*, as well.

In the case of resistive-inductive load and counter-EMF, the gate driver may arrange the line-fed inverting process by enlarging the firing angle more than  $90^\circ$ , as shown in Fig. 39, *d*. It is the typical braking mode of motor drive operation.

**Output curves.** Output curves are placed on the *output diagram* of a converter that describes the load voltage with respect to the load current,  $U_d(I_d)$  in the current-voltage plane. It depends on the load EMF and inner resistances of the converter circuit:

$$U_d = U_0 - \delta U,$$

where the sum of voltage drops  $\delta U$  depends on the number of the current-conducted devices  $k$  having voltage drop  $U_F$ , the load current  $I_d$ , the number of phases  $m$ , and a transformer resistance  $R_p$ , as was discussed earlier in term of the transformer calculation:

$$\delta U = kU_F + I_d R_p + \frac{k m f_1 I_d L_{tr}}{2\pi}$$

In the case of continuous current, the output curves comprise the set of parallel straight lines shown in Fig. 40, *a*. They demonstrate that the higher the output current is, the lower the output voltage drops. Depending on the power, the active and reactive components affect  $\delta U$  differently. Usually in the low-power rectifiers, resistances predominate, whereas in high-power converters the reactance plays the main role. In common cases of restricted load current, voltage usually drops no more than 15...20% of  $U_0$ . In overloading modes, this value grows extensively.

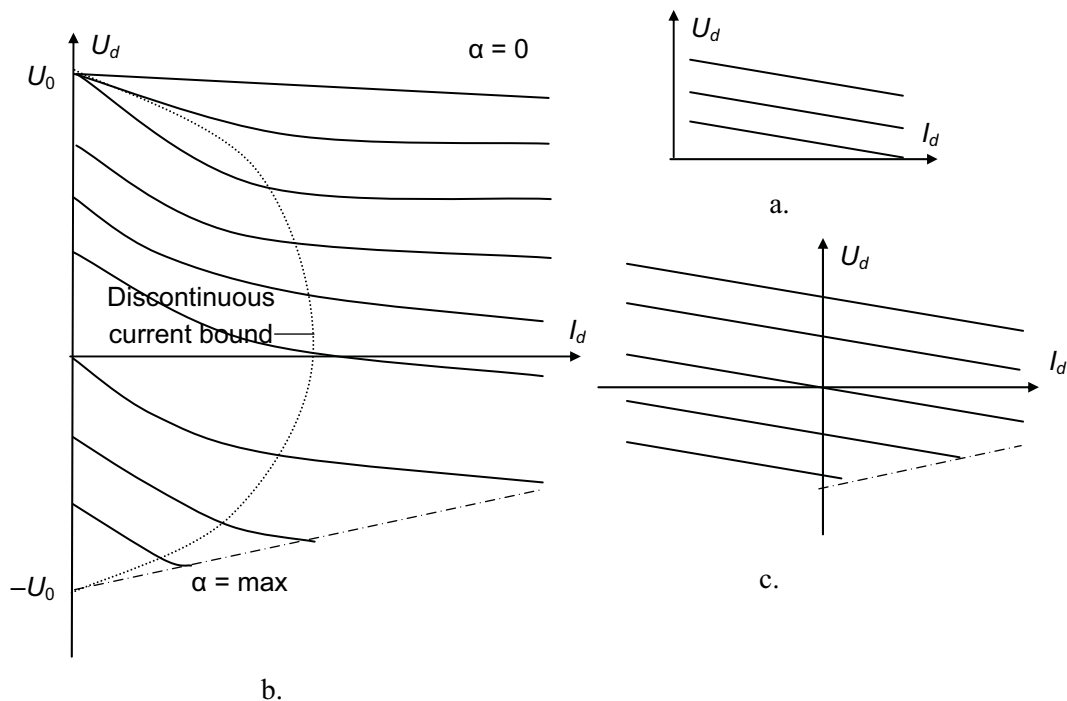

Fig. 40

In the case of low loading, the current approaches discontinuous mode, and the output curves change their shape significantly. Here, the steep slump at the beginning of the diagrams is caused by the current flowing time dependence on the EMF. The ellipsoidal line on the output characteristics in Fig. 40, *b*, shows the discontinuous current boundary. The discontinuous current occurs to the left of this line and the continuous current occurs to the right. Consequently, the characteristics in the continuous current region are linear, exhibiting only a slight droop. In contrast, in the discontinuous current region the curves are strongly nonlinear with the loss in output voltage. The discontinuous current boundary equation is expressed as follows:

$$I_{ab} = \frac{U_0 \sin \alpha}{2\pi f L} \left( 1 + \frac{\pi}{m} \operatorname{ctg} \frac{\pi}{m} \right),$$

where  $m$  is the number of pulses in the rectified voltage,  $L$  is the inductance of the rectified loop, and  $f$  is the rectified ripple frequency.

In the no-load point (zero current and idle operation) when  $\alpha = 0 \dots, \frac{\pi}{m}$ ,

$$U(0) = U_0 - \delta U,$$

## WHY WAIT FOR PROGRESS?

DARE TO DISCOVER

---

Discovery means many different things at Schlumberger. But it's the spirit that unites every single one of us. It doesn't matter whether they join our business, engineering or technology teams, our trainees push boundaries, break new ground and deliver the exceptional. If that excites you, then we want to hear from you.

**Dare to discover.**  
[careers.slb.com/recentgraduates](https://careers.slb.com/recentgraduates)



Schlumberger



where  $\delta U$  is close to zero, whereas when  $\alpha > \frac{\pi}{m}$ ,

$$U(0) = U_0 \cos \alpha - \delta U$$

**Gating of dual rectifiers.** In the two-quadrant and four-quadrant dual rectifiers, the average dc-side voltage should be adjusted from a positive maximum to a negative minimum value. The two-quadrant and four-quadrant dual rectifiers are accomplished by connecting the rectifiers in *anti-parallel* (back-to-back) *circuits* as given in Fig. 6 and Fig. 7.

There are two common methods of the dual thyristor rectifier gating: a separate control and a coordinated control.

In the *separate control* systems, only one rectifier at a time is allowed to conduct. In this case, each rectifier operates independently. The separate control is preferable where the first rectifier conducts when the load current is required to be positive, and the second one when it is required to be negative. Clearly, in order to exclude short circuits between line terminals, only one of the converters can be allowed to conduct at any instant. This, by the way, has the advantage that only one pair of thyristors produces conducting switching losses so that both groups can be mounted on the same heat sink. However, having opposite polarity, they must be electrically insulated from each other. At lower power rating, complete thyristor modules are available, having the necessary interconnections built-in.

Here, the firing unit switches off the first rectifier and, when the other rectifier is required, it switches on with some delay. In order to prevent short-circuiting in the rectifier leg, there should be a lockout time between the turn-off of one rectifier and the turn-on the next. The delay as the current passes through zero, while the thyristors in one device safely turn off before those in the second are opened must be larger than the maximum particle storage time of a rectifier. This delay introduces a discontinuous-current mode with a current-free period of typically near 5 to 10 ms.

The effect of the dead time is a distortion on the voltage level. The distorted current flows through the load and the load curves become non-linear, with a narrow discontinuous area (Fig. 41, *a*). In high-quality drive system, the dead time compensation is mandatory to avoid voltage distortion to cause instabilities at low frequency. The hardware and the software compensation may be used.

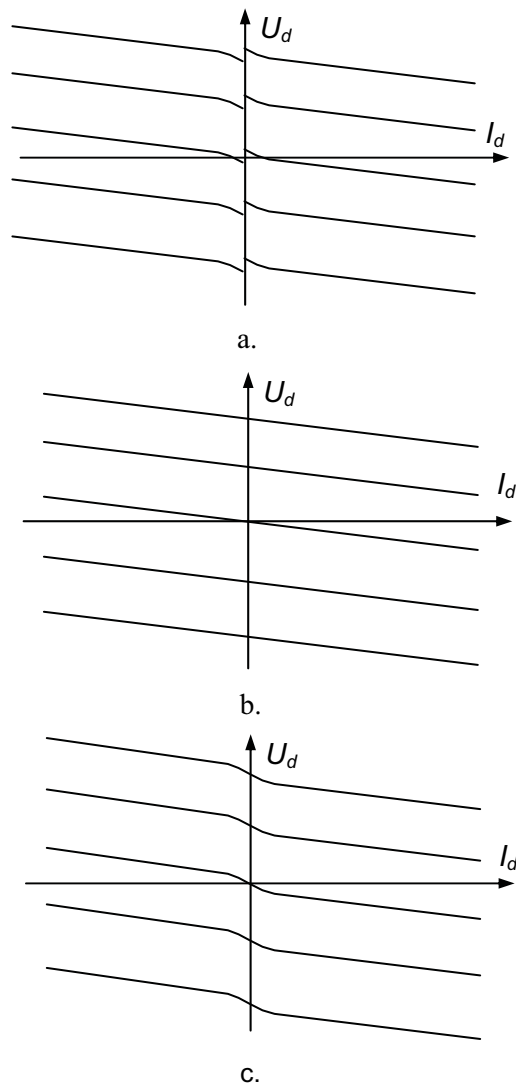

Fig. 41

In contrast, in *coordinated control* systems both rectifiers are controlled simultaneously to give the same mean output voltage. As a result, a new current loop appears which does not include the load. The current flowing through this loop built by the second group of thyristors is known as a *circulating current*. Thus, the coordinated control burns the dual rectifiers with circulating current. However, the instantaneous voltage from both devices cannot be identical; therefore, reactors are included into the power circuit to limit the current circulating between them. The principal advantage of these systems is that when the current is required to change direction, there is no need for a delay between the conduction of one rectifier and the other.

The circulating current is a parasitic one, which results in the system's power increasing. Its value depends on the instant voltage differences of both rectifiers and the resistance of the

loop. Theoretically, to avoid a discontinuous current through the load, the firing angles of both rectifiers,  $\alpha_1$  and  $\alpha_2$ , should be calculated in accordance with the equations:

$$\alpha_1 + \alpha_2 = \pi; \alpha_1 - \alpha_2 = \pi$$

In practice, the two methods of the coordinated control of the thyristors are used.

In the *joint coordinated control* systems, the firing unit performs control by the following law:

$$\alpha_1 + \alpha_2 = \pi$$

Thus, the mean values of the voltages are equal, but their instantaneous values are different and the circulating reactor is included into the dual rectifier to consume this difference. The continuous current flows through the load while the circulating current travels through the reactor, thyristors, and windings. Figure 41, *b* shows the appropriate output characteristics. The advantage of this system is that when the current changes its direction, the output characteristics are linear and there is no delay between the conduction of one rectifier and the other.

SIMPLY CLEVER

ŠKODA



**We will turn your CV into an opportunity of a lifetime**



Do you like cars? Would you like to be a part of a successful brand? We will appreciate and reward both your enthusiasm and talent. Send us your CV. You will be surprised where it can take you.

Send us your CV on  
[www.employerforlife.com](http://www.employerforlife.com)



Click on the ad to read more

In the *joint non-coordinated control* systems, the firing unit performs according to a simpler control law:

$$\alpha_1 + \alpha_2 > \pi.$$

In this case, the mean values of the voltages are almost equal, and again the circulating reactor consumes the difference of their instantaneous values. The discontinuous current flows through the load, and the circulating current travels through the reactor, thyristors, and windings. The output characteristics are non-linear, with narrow discontinuous area (Fig. 41, c) yet the low parasitic circulating current results as the system power grows as compared with the *circulating current-free mode*.

With a dc supply, there is no natural commutation available and other methods of device switching have to be employed.

**Gating of a cycloconverter.** Each thyristor group of the cycloconverter shown above in Fig. 23 includes the three-phase midpoint rectifier. The first alternation of the output voltage is produced by the anode thyristor group; the second by the cathode group. For such operation, the non-conducting group is blocked when the other group conducts.

An operation diagram of the cycloconverter circuit is shown in Fig. 42. The supply voltage  $U_{s\ sup}$  is shown by the curves  $U_{L1}$ ,  $U_{L2}$ ,  $U_{L3}$ . The average output voltage of each thyristor triplet varies as the cosine of the firing angle. The successive firing angles can be changed by the gate signals  $I_G$  so that the average output voltage obtains the sinusoidal envelope.

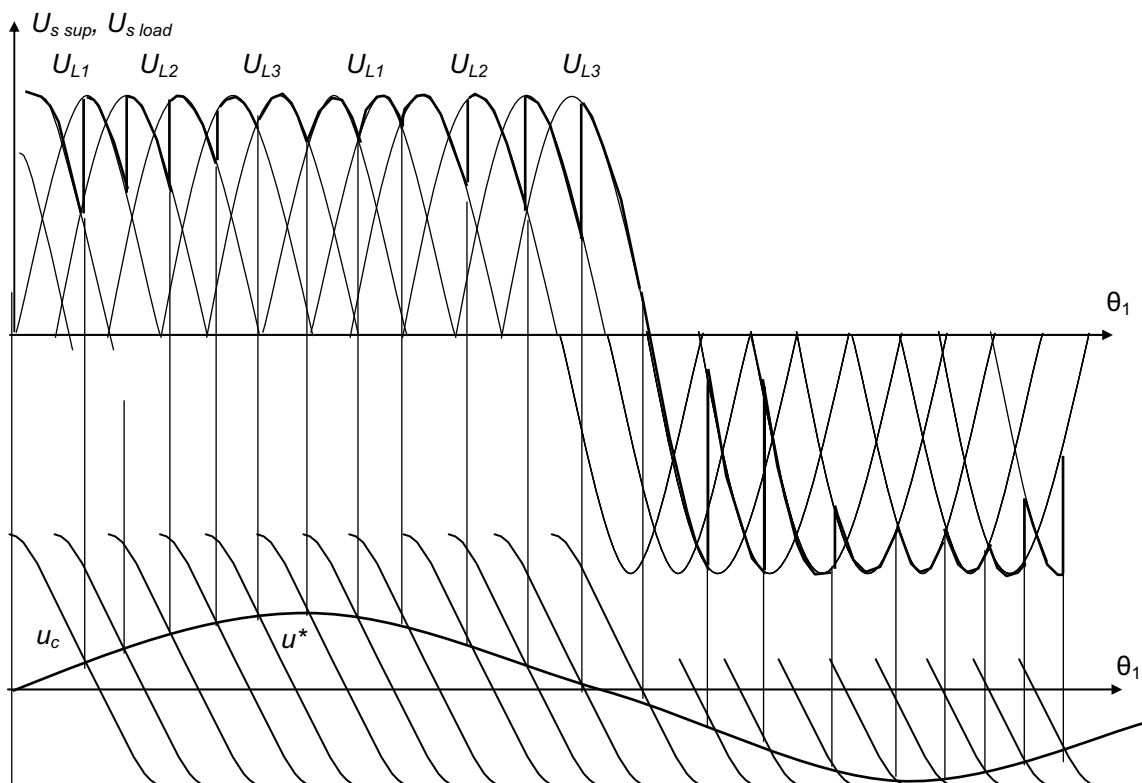

Fig. 42

Generation of such output voltage from the free-phase input voltages may follow two algorithms: with the pulse duration  $120^\circ$  as well as  $180^\circ$ . In both cases, these pulses determine the time intervals for the output voltages production. These voltages have the necessary sign and phase shift. Pulsing with  $\pi$  pulse duration is illustrated in Fig. 43. Phase-to-phase output voltages of cycloconverter are similar to the same voltages of the three-phase midpoint rectifiers having separate control. The only difference is that the positive and negative outputs are equal here. Each time when a triplet of thyristors switches off and the next triplet has to be on, thyristors change their mode of operation from rectifying to inverting and the voltage sign changes. Since the current falls down to zero, the rectifying and inverting groups are blocked, and further the next group switches on with the current rising due to the positive voltage.

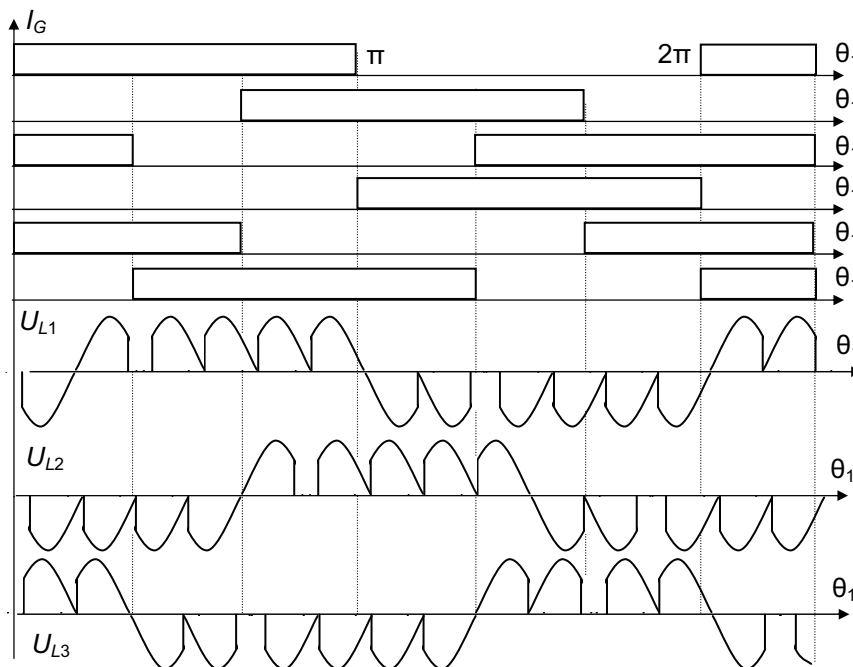

Fig. 43

As Fig. 42 shows, polarity of the desired voltage  $u^*$  defines the polarity of the output voltage  $U_{s\ load}$ , the amplitude of  $u^*$  displays the desired average output voltage, and the frequency of  $u^*$  represents the output frequency of  $U_{s\ load}$ . Zero average voltage is required at the starting instant and therefore the firing angle in this point equals  $90^\circ$ . During the positive half-cycle of  $u^*$ , the rectified thyristors are fired, and during the negative half-cycle the inverting devices are fired. As  $u^*$  increases, the firing angle decreases. At the peak value of  $u^*$  the firing angle is minimum. Further, the firing angle raises and later decreases in appropriate steps. The output voltage waveform of Fig. 42 displays the case when the output frequency is measured by the quarter of the input frequency. Because the reference voltage alters with time during half-cycle instead of remaining constant, the firing angles change in the half-cycle as well.

The control curve of the cycloconverter supplied by the three-phase voltage  $U_{s\text{ sup}}$  is described by the equation:

$$U_{s\text{ load}} = \frac{24U_{s\text{ sup}}}{\pi^2} \sin \frac{\pi}{3} \sin \frac{\pi}{6} \cos \alpha$$

**Summary.** The core of a thyristor gate circuit is the phase-shifting gate driver that compares the reference signal of the controller with the periodic carrier signal of the generator synchronized by the supply voltage. Simple gate circuit provides a single-quadrant operation of the rectifier whereas systems that are more complex are required for the multi-channel pulse distribution. Operation diagrams and control curves of the gate circuits depend on the continuous or discontinuous mode of operation.

## 2.2 BLOCK MODULATION

**Gating of single-phase bridges.** The best of desired ac converters would be a device that generates pure sinusoidal waves of symmetrical phases as well as the best of desired dc converters would be a device that generates pure linear supply. Unfortunately, any converter

I joined MITAS because  
I wanted **real responsibility**

The Graduate Programme  
for Engineers and Geoscientists  
[www.discovermitas.com](http://www.discovermitas.com)



**Month 16**  
I was a construction supervisor in the North Sea advising and helping foremen solve problems

Real work  
International opportunities  
Three work placements



**MAERSK**

is a source of voltage and current waveforms having more or less distortion. The distortion profile and level depend on the modulation principle of the gate circuit.

In Fig. 44, *a*, the operation diagram of the single-phase bridge inverters shown in Fig. 10, *c*, is displayed. In the first modulating half-period, transistors **VT1** and **VT4** are in on state whereas transistors **VT2** and **VT3** are in off state. Thus, the source dc voltage  $U_s$  supplies the load. In the second half-period, **VT1** and **VT4** switch off whereas **VT2** and **VT3** switch on, therefore the polarity of the load supply changes. As the load has an inductance, the current shown by dotted lines cannot change its direction instantly, thus the freewheeling diodes pass the current during the part of the half-period.

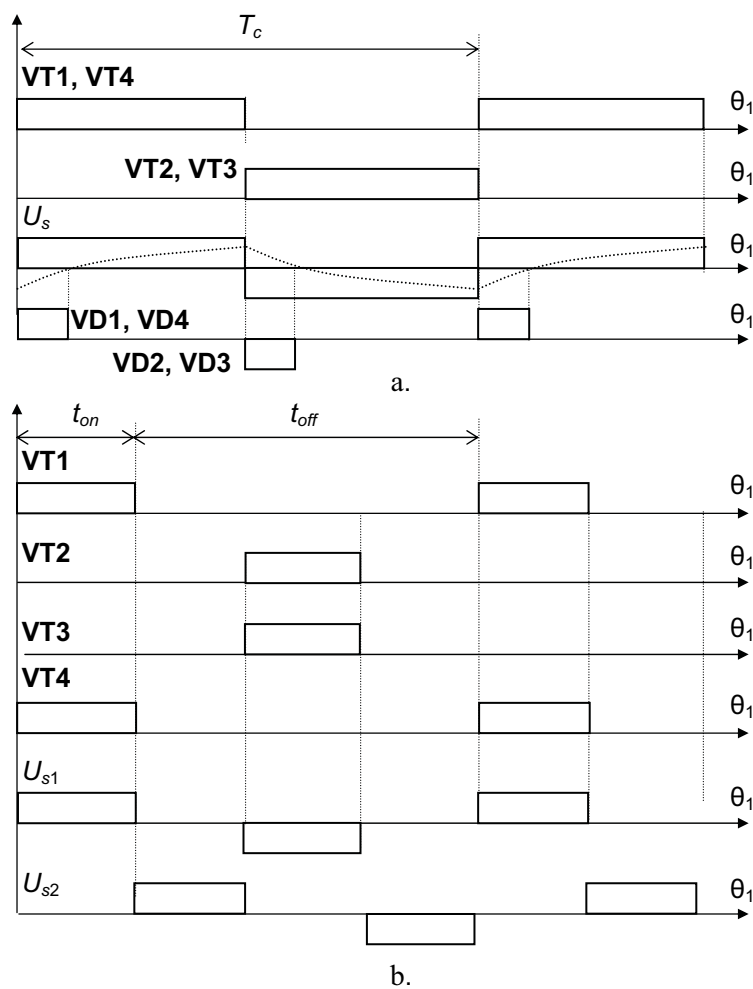

Fig. 44

Figure 44, *b*, illustrates the method known as *phase-shift block modulation*, which is also popular in transistor bridges. Unlike the simple rectangle modulation where only the frequency is subjected to adjustment, the phase-shift approach is suitable to simultaneous voltage and frequency control that is the most widespread problem among ac drive applications. In Fig. 44, *b*, the timing diagram of the single-phase bridge inverters shown in Fig. 10,



$c$ , is proposed. At the beginning of the first modulating period, transistors **VT1** and **VT4** switch on, whereas transistors **VT2** and **VT3** are in off state. During  $t_{on}$ , the source dc voltage  $U_{s1}$  supplies the motor control winding. At the end of this interval, **VT1** and **VT4** switch off and the control winding remains unsupplied during the time interval  $t_{off}$ . In the next interval  $t_{on}$ , **VT2** and **VT3** switch on, thus the polarity of the control winding supply changes. The duty cycle

$$q = \frac{t_{on}}{T_c} \tag{2}$$

is proportional to the alternating gate pulse frequency although the full period remains constant. When this method is used to control a two-winding ac motor (Fig. 10,  $d$ ), the corresponding diagram of the excitation winding supply voltage  $U_{s2}$  is similar, with  $90^\circ$  shift.

The circuit diagram of the forward full-bridge chopper shown Fig. 27,  $c$ , is the same as for single-phase bridge inverter of Fig. 10,  $c$ , thus, the output voltage depends only on the modulation method. A symmetrical control, which results in ac output, and an asymmetrical control resulting in ac or dc output are possible in this circuit. In the timing diagrams of Fig. 44,  $a$ , all switches change their state simultaneously. During the first phase, transistors **VT1** and **VT4** are switched on in the on period and diodes **VD2** and **VD4** conduct in the off period. With transistors **VT2** and **VT3** conducting, the current is reversed and hence the full four-quadrant inverting operation is obtained.

In the case of asymmetrical control depicted by the timing diagrams of Fig. 44,  $b$ , the regulation of the output ac voltage is provided by shifting the output of one switching group with respect to the other to control the zero-voltage interval. To obtain the unipolar ac voltage, both transistors in the left leg, **VT1** and **VT3**, are controlled to ensure that with one of them in off state, another one is on (Fig. 45). Both transistors in the second leg, **VT2** and **VT4** are controlled with a duty cycle  $1 - q$  obtained from a switch-off pulse with a time shift. Thus, switches **VT2** and **VT4** change their state while the switch **VT1** is open and **VT2** is closed. The duty cycle is controlled to achieve the output voltage regulation by means of zero intervals between the positive and the negative applied voltages.

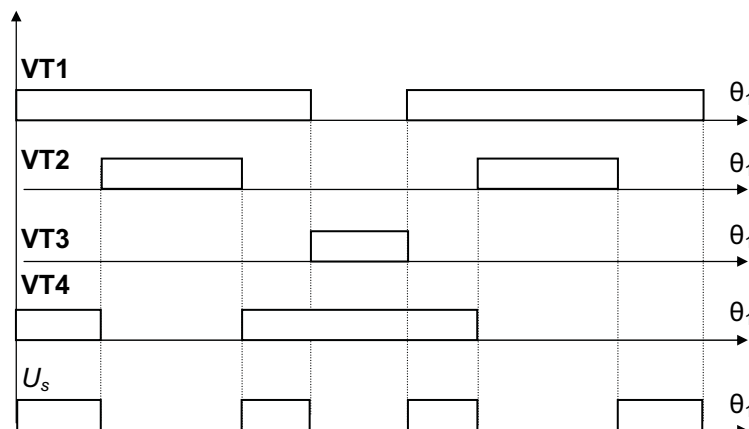

Fig. 45

Obviously, the asymmetrical control makes it possible to reduce the current ripple without modifying the switching frequency.

**Output curves.** Analysis of the output curves begin from the simple single-switch converters like choppers led by block modulation. Their instantaneous load currents depend on the circuit and control mode.

In the single-quadrant step-down chopper, the output voltage versus average load current varies linearly with the duty cycle, as the solid traces in Fig. 46, *a* show. Dotted lines describe discontinuous current mode. If the load resistance is  $R$  and the rated load current is  $I_{d\ load}$ , then the mean value of the voltage should be  $RI_{d\ load}$ , therefore

$$q = \frac{RI_{d\ load}}{U_{d\ sup}}$$

**ie** business school

#1 EUROPEAN BUSINESS SCHOOL  
FINANCIAL TIMES 2013

#gobeyond

**MASTER IN MANAGEMENT**

**Because achieving your dreams is your greatest challenge.** IE Business School's Master in Management taught in English, Spanish or bilingually, trains young high performance professionals at the beginning of their career through an innovative and stimulating program that will help them reach their full potential.

- Choose your area of specialization.
- Customize your master through the different options offered.
- Global Immersion Weeks in locations such as London, Silicon Valley or Shanghai.

*Because you change, we change with you.*

www.ie.edu/master-management | mim.admissions@ie.edu |

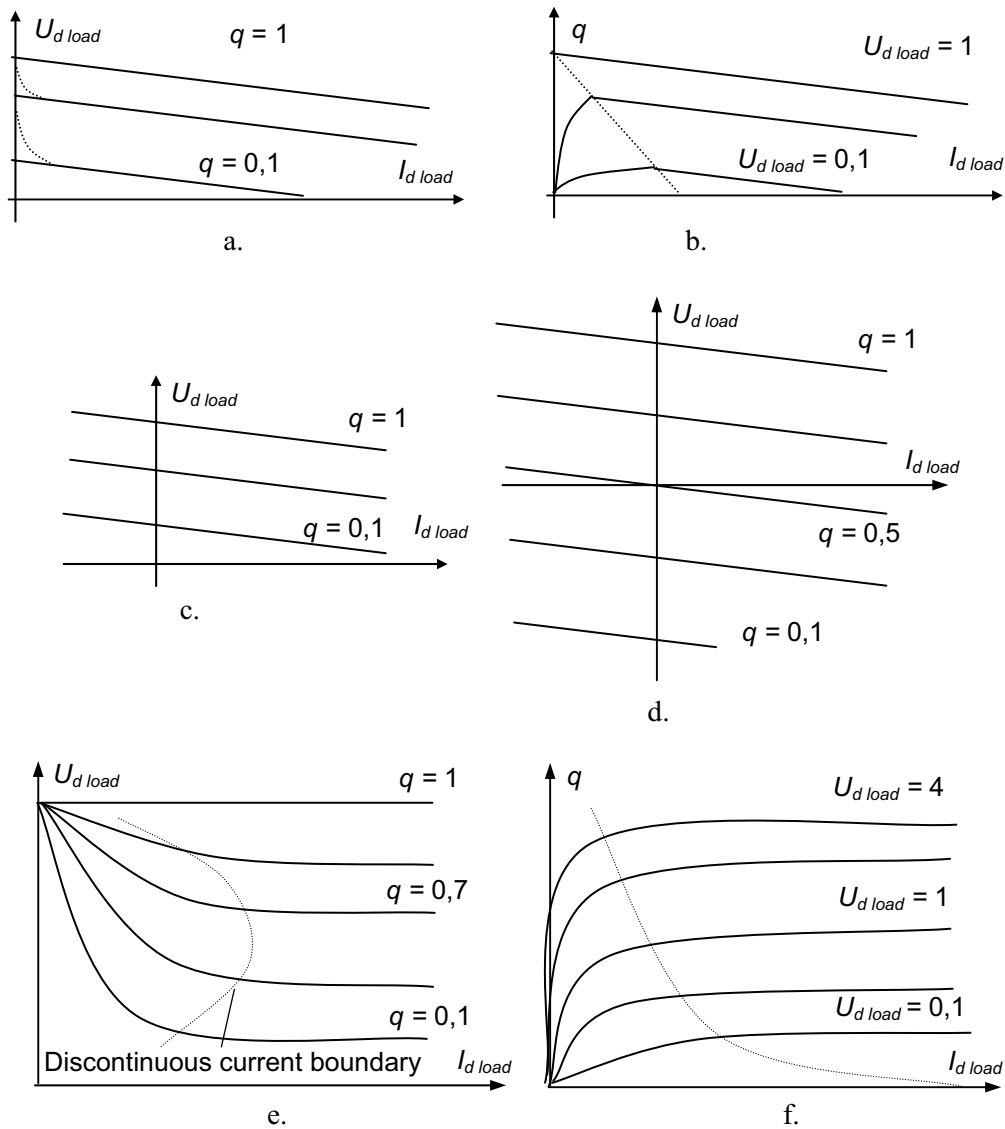

Fig. 46

When the load current  $I_{d\ load}$  decreases, the converter passes from the continuous operation to the discontinuous operation. The border between these two operations is drawn by a dotted line in Fig. 46, *b*.

The two-quadrant forward chopper is able to reverse the average current flow of the load but unable to reverse the load terminal voltage, as the load curve in Fig. 46, *c*, shows.

In the four-quadrant forward chopper with symmetrical control,

$$I_{on} = \frac{U_d}{R} \left( 1 - 2 \frac{1 - k_2}{1 - k_1 k_2} \exp \frac{-t}{T} \right) - \frac{E}{R}$$

$$I_{off} = \frac{U_d}{R} \left( 1 - 2 \frac{1-k_1}{1-k_1k_2} \exp \frac{-t}{T} \right) - \frac{E}{R},$$

and with asymmetrical control

$$I_{on} = \frac{U_d}{R} \left( 1 - \frac{1-k_2}{1-k_1k_2} \exp \frac{-t}{T} \right) - \frac{E}{R}$$

$$I_{off} = \frac{U_d}{R} \left( 1 - 2 \frac{1-k_1}{1-k_1k_2} \exp \frac{-t}{T} \right) - \frac{E}{R}$$

where

$$k_1 = \exp \frac{-qT_c}{T}$$

$$k_2 = \exp \frac{(q-1)T_c}{T}$$

$$T_c = \frac{1}{f_c}, T = \frac{L}{R}, E = qU_d - RI_{on}$$

Here,  $f_c$  is the carrier frequency,  $R$  and  $L$  are the load resistance and inductance, and  $E$  is the load EMF.

In the four-quadrant forward chopper with symmetrical control, the full four-quadrant operation is obtained as curves in Fig. 46, *d*, show. When asymmetrical control is used, the same curves correspond to  $-1 < q < 1$ .

The output characteristics of the boost converter depend on the duty cycle. When the load current  $I_{d load}$  decreases, the converter passes from the continuous operation to the discontinuous operation and the voltage  $U_{d load}$  changes, as shown in Fig. 46, *e*, *f*.

**Gating of three-phase bridges.** For the three-phase bridge VSI shown in Fig. 11, two algorithms of block modulation are the most popular: the algorithm with the  $120^\circ$  switch open state interval and the algorithm with the  $180^\circ$  interval.

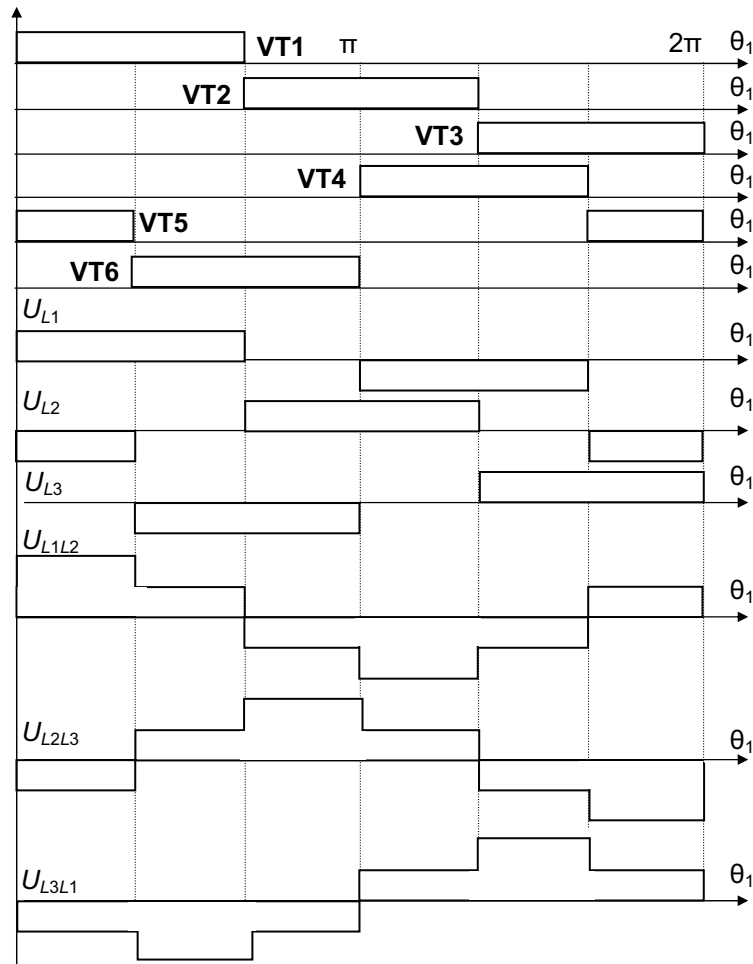

Fig. 47

When the first method is applied, the states of the switch and the voltages of the phase have the waveforms plotted in Fig. 47. The switching sequence is in the order **VT1–VT6–VT2–VT4–VT3–VT5–VT1...** To switch the load off, two zero states may be used: **VT1–VT2–VT3** or **VT4–VT5–VT6**. Each phase is under the current during a  $\frac{1}{3}$  period and closed during a  $\frac{2}{3}$  period. The time duration of the full switching period ( $2\pi$ ) depends on the required modulating frequency that is referred to by the reference code  $u^*$ , thus, the output frequency may be changed simply. Since the supply dc voltage is kept constant, the inverter output voltage has constant amplitude anywhere.

For the second method, the states of the switch and the phase, neutral, line-to-neutral, and line-to-line voltages have the waveforms plotted in Fig. 48. Here, the switching on of the three half-bridges is phase-shifted by  $120^\circ$ . Each phase is under the current during half a modulating period and closed during another half a period. In accordance with the described algorithm, a specific phase is alternately switched from the positive pole to the negative one and that it is alternately in series with the remaining two phases connected in

parallel. When **VT1** is switched on, the load phase  $L1$  is connected to the positive terminal of dc supply, resulting in  $U_{L1} = \frac{U_d}{2}$ . When **VT4** is switched on, the phase  $L1$  is connected to the negative terminal of dc supply, resulting in  $U_{L1} = -\frac{U_d}{2}$ . Waveforms of  $L2$  and  $L3$  are the same as those of  $L1$ , except that they are shifted by  $120^\circ$ .

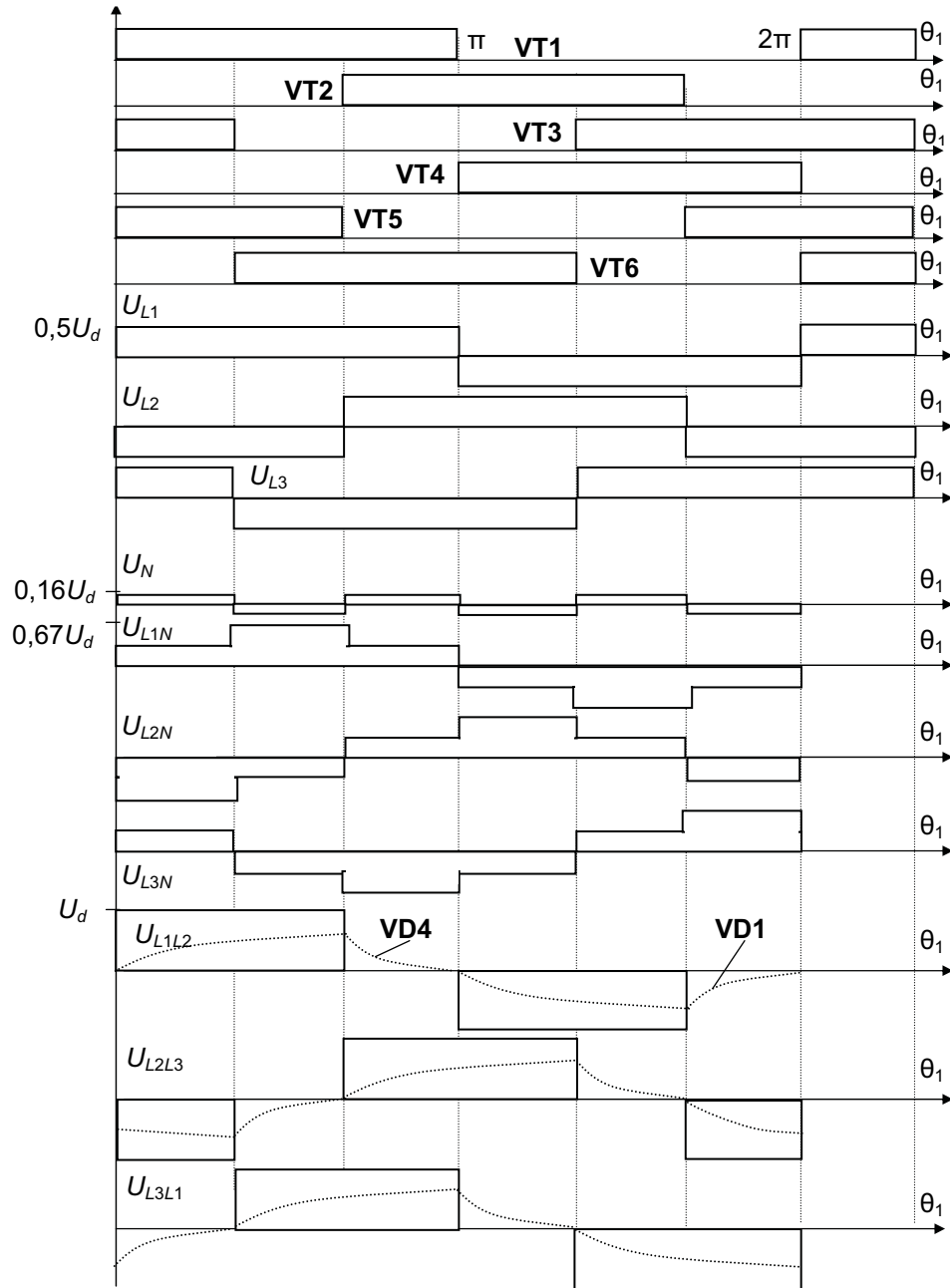

Fig. 48

**Voltage-current analysis.** The rms value of the line-to-neutral voltage of the load for the described operation depends on the dc link voltage. This voltage can be expressed as

$$U_{LN} = \frac{\sqrt{2}U_d}{3} = 0,47U_d$$

For the balanced three-phase operation

$$U_{L1} + U_{L2} + U_{L3} = 0 \quad (3)$$

At the same time, the three-phase voltage system of the legs measured relatively the load neutral is unbalanced and can be written as

$$U_N = \frac{U_{L1} + U_{L2} + U_{L3}}{3} \quad (4)$$

The neutral potential of the triple frequency is either positive or negative as two upper or lower transistors are on in the inverter leg. From here, the load phase (line-to-neutral) voltages may be obtained as follows:

$$U_{L1N} = U_{L1} - U_N \quad U_{L2N} = U_{L2} - U_N \quad U_{L3N} = U_{L3} - U_N \quad (5)$$

"I studied English for 16 years but...  
...I finally learned to speak it in just six lessons"

Jane, Chinese architect

ENGLISH OUT THERE

Click to hear me talking before and after my unique course download



Therefore, in each phase the voltage drops to  $\pm\frac{U_d}{3}$  or  $\pm\frac{2U_d}{3}$  with the polarity of the voltage drop across the phase being determined by whether it is connected to the positive or negative pole. They have a characteristic six-stepped wave shape. The presence of six steps in the line-to-neutral modulation period of the voltage waveform is the reason why this type of modulation is called a *six-step modulation*.

The instantaneous load phase currents may be described as follows:

$$I_{0...60^\circ} = \frac{U_d}{3R} \left( 1 - \frac{(1+k) \cdot (2-k)}{1+k^3} \exp\frac{-t}{T} \right)$$

$$I_{60^\circ...120^\circ} = \frac{U_d}{3R} \left( 2 - \frac{(1+k)^2}{1+k^3} \exp\frac{-t}{T} \right)$$

$$I_{120^\circ...180^\circ} = \frac{U_d}{3R} \left( 1 - \frac{(1+k) \cdot (1-2k)}{1+k^3} \exp\frac{-t}{T} \right)$$

where

$$k = \exp\frac{T}{mf_1}, \quad T = \frac{L}{R}$$

Here,  $R$  and  $L$  are the load resistance and inductance,  $m = 6$ ,  $f_1$  – supply frequency. These currents are shown by dotted lines along with the freewheeling diodes signals, which pass the tail current since the transistor switch-off.

The line-to-line voltages are related to the phase voltages as follows:

$$U_{L1L2} = U_{L1} - U_{L2}, \quad U_{L2L3} = U_{L2} - U_{L3}, \quad U_{L3L1} = U_{L3} - U_{L1} \quad (6)$$

The rms value of the load line-to-line voltage is equal to

$$U_{LL} = \sqrt{\frac{2}{3}} U_d = 0,82U_d$$

These voltages form square waves with  $120^\circ$  pulse widths.

Fourier analysis of these waveforms indicates a square-wave type of geometric progression of the harmonics, i.e., the line-to-line and line-to-neutral waveforms contain  $1/5^{\text{th}}$  of the fifth

harmonic,  $1/7^{\text{th}}$  of the seventh harmonic, and so on. Harmonics of order three and multiples of three are absent from both the line-to-line and line-to-neutral voltages and consequently from the currents. The line-to-line voltage contains an rms fundamental component  $\frac{\sqrt{6}U_d}{\pi}$ .

So, a standard 460 V load would require 590 VDC at the dc terminals. For this reason a 600 VDC bus is quite standard in US and in other countries for inverter loads. Standard 380 V load requires 487 VDC and 400 V needs 512 VDC.

The six-step algorithm provides higher usage of the supply voltage and less output distortion as compared with the first switching mode. At the same time, converter logical structure at both described switching modes is constant because the number of open and closed transistors is equal and does not change during the full modulating period. This is the main advantage of the described modulation methods. Other switching algorithms are possible also. For example, the open state interval may continue  $150^\circ$  instead of  $180^\circ$  as well as the switching order VT1–VT6, VT1–VT2–VT6, VT2–VT6, VT2–VT4–VT6, VT2–VT4, VT2–VT3–VT4, VT3–VT4, VT3–VT4–VT5, VT3–VT5, VT3–VT5–VT1, VT5–VT1, VT5–VT1–VT6. This leads to the variable structure of the converter.

**Switching table.** A switching model of Fig. 49, a, simulates the discussed three-phase inverter circuit shown in Fig. 11. Each load terminal assumes a potential defined by the control. The legs' short-circuiting is avoided here since the terminals are connected to the positive or negative supply bus. In other words, the state of one switch in a leg is off while another is conductive, except for the short protective intervals, when both of switch contacts are broken. The protective interval, which, in practice, lasts only for a few microseconds, can be assigned to a finite switching time in the proper converter model.

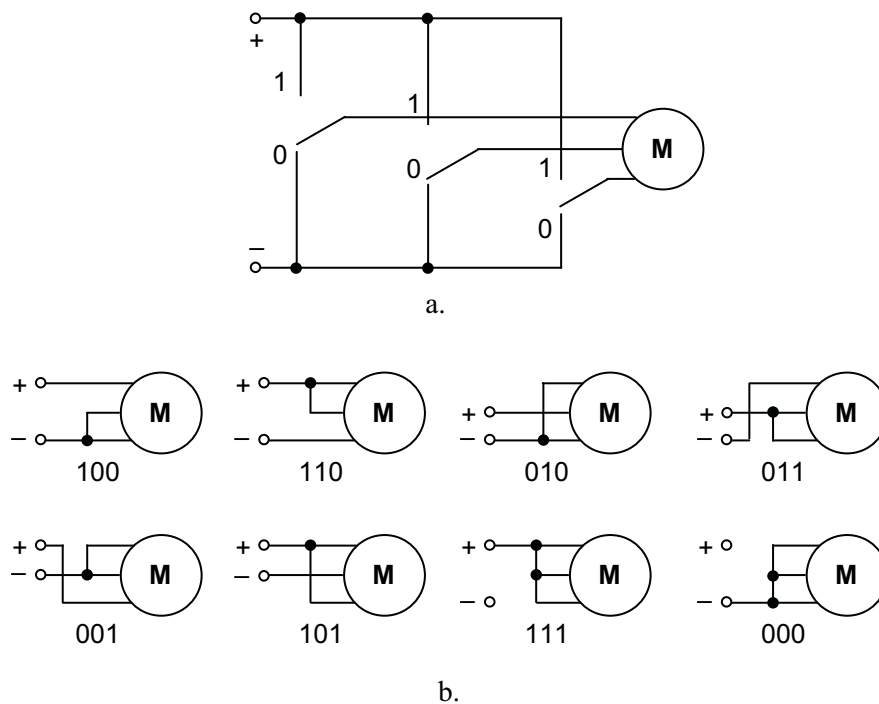

Fig. 49

The reversing switches may be designated by the binary variables, which indicate whether the switch is in the top (1) or in the bottom (0) position. Accordingly, a three-bit binary word with eight different values defines all possible switching states of the converter: 100, 110, 010, 011, 001, 001, 101, 111, and 000. These states are shown in Fig. 49, *b*.

Figure 50 illustrates the transposition of the first six model states into the phase voltages of Fig. 11. During the modulating period, a phase voltage may be equal to  $\pm \frac{2U_d}{3}$ ,  $\pm \frac{U_d}{3}$ , or zero depending on which transistors are switched on. Clearly, to produce the typical six-step output voltage, only one pair of the inverter switches needs to change its state (similar to the Gray coding rule). These switches are linked in the *switching table* of Fig. 50. Other transistors keep their previous states until the next switching.

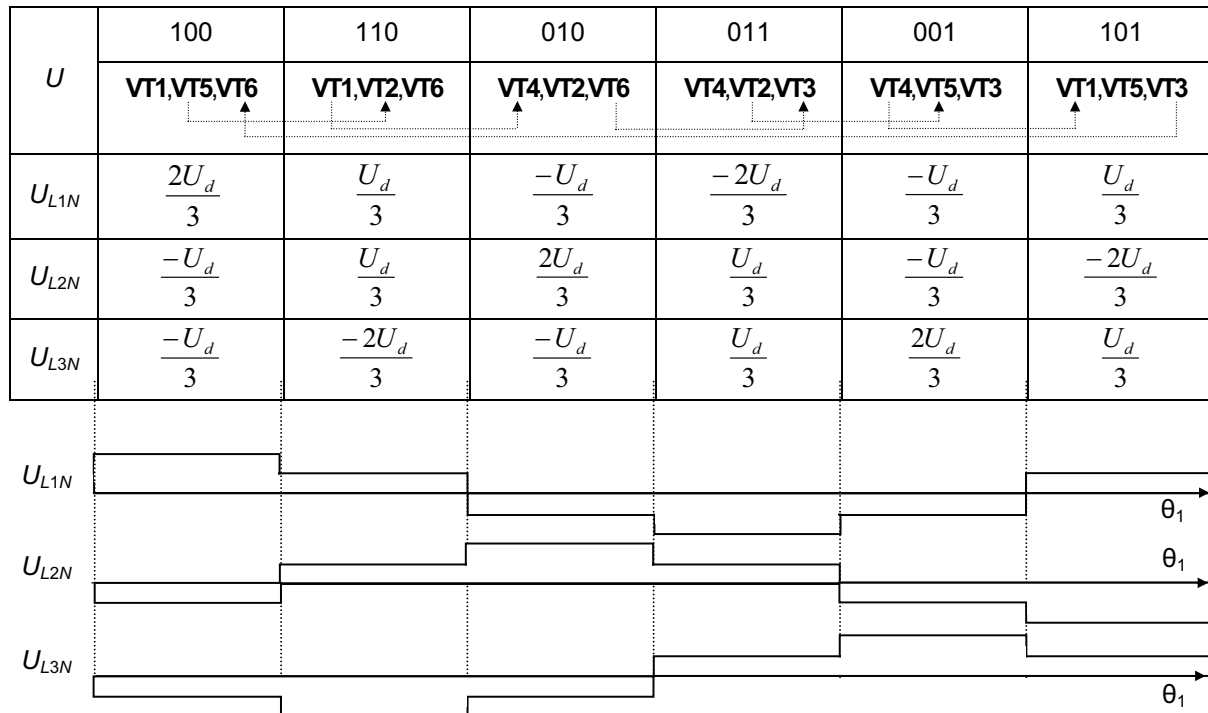

Fig. 50

**Summary.** The advantages of the square-wave modulation are: high efficiency (close to 98%), potentially good reliability, and high-speed capability. A simple form of block modulation results in minimum switching duty of the semiconductor switches. Thus, a constant switching frequency scheme guarantees fast response together with the a limited steady-state tracking error.

Commonly, voltage control is impossible in the simple block modulated driver circuits; this is their drawback. Therefore, the square-wave modulation is normally used in low-power applications where the voltage range is fixed and dynamic performance is not important.

Examples are frequency changers and inverters with dc controlled input. The need in a phase-controlled rectifier to control the voltage of the inverter is an inherent weakness of this circuit. A line-commutated rectifier supplying the dc link is particularly notorious often because it does not only produce the line currents with low orders of harmonics, but draws also substantial reactive currents of line frequency. Its large compensative capacitor slows the response time of the system.

Another disadvantage of the block modulated ac converters is that they suffer from low-voltage pulsations due to non-sinusoidal voltage shape, which leads to the load current pulsations and instability with extra energy losses especially when the frequency is low. In such inverters, harmonic voltage amplitudes are inversely proportional to the harmonic order. Thus, the six-step mode is the worst with respect to voltage harmonic content with 20% of the 5<sup>th</sup> harmonic, 14% of the 7<sup>th</sup> and so on. Hence, there are no pronounced high-order harmonics. These are filtered out by the load inductances.

Excellent Economics and Business programmes at:



university of  
 groningen



“The perfect start  
 of a successful,  
 international career.”

**CLICK HERE**  
 to discover why both socially  
 and academically the University  
 of Groningen is one of the best  
 places for a student to be

[www.rug.nl/feb/education](http://www.rug.nl/feb/education)

## 2.3 PULSE-WIDTH MODULATION

**PWM technique.** The *pulse-width modulation* or the PWM method is now gradually taking over the inverter market of control applications. This technique combines both voltage and frequency control. The PWM circuit output is the chain of constant amplitude pulses, in which the pulse duration is modulated to obtain the necessary specific waveform on the constant pulsing period. In modern converters, PWM is the high-speed process ranging from a few kilohertz in simple motor control systems up to several megahertz in resonant converters for power supply.

In the converters discussed above, the dc link voltage is often uncontrolled and derived from a simple diode bridge. In the case of PWM modulation, the controlled output voltage is easily obtained by switching the transistors on and off many times within a cycle to generate a variable-voltage output which is normally low in harmonic content. This is the reason why the active rectifiers are often known as *PWM rectifiers* and a majority of inverters is called *PWM inverters*.

Performance of the *PWM converter* significantly depends on the control method and the type of modulation. The pulse-width modulators are now available in a variety of designs and integrated circuits, which greatly simplifies the design. A large number of PWM techniques exist each having different performance notably in respect to the stability and audible noise of the load. Therefore, PWM methods should perform some general demands like: a broad range of linear operation, a minimal number of switching to keep low switching losses in power components, a low content of higher harmonics in voltage and current, because they produce additional losses and noise in load, as well as elimination of low frequency harmonics to avoid motor torque pulsations.

In general, modulation techniques fall into two classes. Those in which the pulse width continuously changes are known as sinusoidal PWM whereas those which operate at a fixed pulse widths grouped in blocks are called picket PWM.

**Sinusoidal PWM.** The objective of the *sinusoidal modulation* (also called suboscillation PWM) is to synthesize voltages that produce currents as close to sinusoidal as economically possible. With the PWM control, the switching signals are generated by comprising a switching-frequency carrier triangular waveform  $u_c$  with the modulation signal  $u^*$ , as shown in Fig. 51, *a*, for the standard single-phase bridge inverter of Fig. 10, *c*. This is the reason why the described PWM is known also as a carrier-based modulation. When  $u^* > u_c$ , two transistors are turned on and another two are turned off. The switching duty cycle can be obtained from the waveforms for switching by (2) and for turning off as

$$q_{off} = 1 - q$$

The duty cycle  $q$  can change between 0 and 1 depending on the magnitude and the polarity of  $u^*$ . Due to the voltage jumps between  $+U_s$  and  $-U_s$ , this switching strategy is referred to as the *bipolar voltage-switching PWM*. The average output current can be either positive or negative. The unipolar output is also possible.

The other ratio is correct also on a half-period of the modulating signal or its fundamental harmonic:

$$q = \frac{1}{2} \left( 1 + \frac{u^*}{u_{c \max}} \right)$$

The last equation shows that the average output voltage changes linearly with the modulating signal, similarly to a linear amplifier. Particularly, if  $u^* = u_{c \max}$ , then  $q = 1$ , if  $u^* = -u_{c \max}$ , then  $q = 0$ , and if  $u^* = 0$ , then  $q = 0,5$ . Examples are in Fig. 51, *b*.

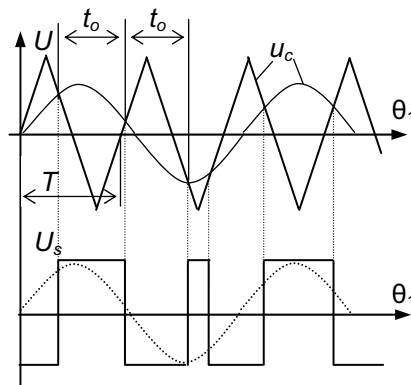

a.

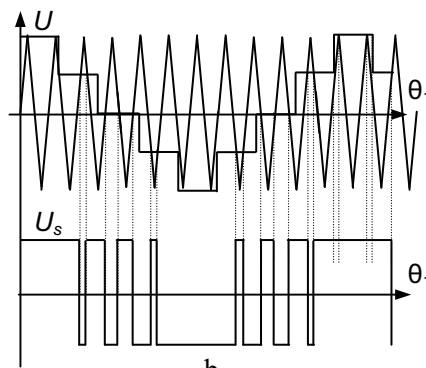

b.

Fig. 51

In the PWM, the waveform of pulse pattern depends on the ratio of the peak  $u^*$  to the peak  $u_c$ . Here, the *carrier ratio (frequency ratio)* determines the number of pulses in each cycle of the inverter output voltage:

$$k_f = \frac{f_c}{f^*},$$

where  $f_c$  is the carrier frequency and  $f^*$  is the modulation frequency. The higher this ratio, the more sinusoidal is the output current. Typically,  $k_f = 50 \dots 500$ .

The *modulation index (modulation ratio)* determines the height of the pulses and hence the rms value of the inverter output voltage is

$$k_{mod} = \frac{u_{\max}^*}{U_{c \max}}$$

In the case of the sinusoidal PWM, the ideal maximum modulation index is equal to unity. Different PWM schemes allow  $k_{mod} < 1$  that represents an important performance criterion, as the inverter maximum power depends on the maximum voltage at load terminals.

In non-sinusoidal PWM schemes,  $k_{mod} > 1$  is also possible. This is known as an *overmodulation*. The operation in the overmodulation area can cause the problems from the control viewpoint as well as in the application behavior.

Often, the carrier and modulation signals are to be synchronized, that is there must be a fixed number of carrier cycles in each modulating period. If this number is chosen to give a “good” sinusoidal current waveform at low frequency, say a 1 Hz, then the ratio  $k_f$  will be in the neighborhood of 100. If the same ratio is then used at a motor frequency of 100 Hz, the carrier frequency becomes 10...20 kHz. This switching frequency may be far too high for some kinds of devices, say, bipolar transistors. Hence, a technique of “*gear changing*” is employed which reduces  $k_f$  in step as the modulation frequency increases. The majority of commercially available systems built on the custom chips are designed in such a way.

One frequently used three-phase PWM algorithm is illustrated in Fig. 52 for the bridge circuit shown in Fig. 10. The sinusoidal modulation signals  $u^*$  specify the required output waveforms. To obtain balanced three-phase output voltages in a three-phase PWM inverter, three reference sinusoidal modulated voltages that are  $120^\circ$  out of phase are needed, one per each phase. The high-frequency triangle carrier signal  $u_c$  is also required. Its frequency is typically 2 kHz to 200 kHz. The natural intersections of  $u^*$  and  $u_c$  determine both the offset and the duration of the gate control signals.



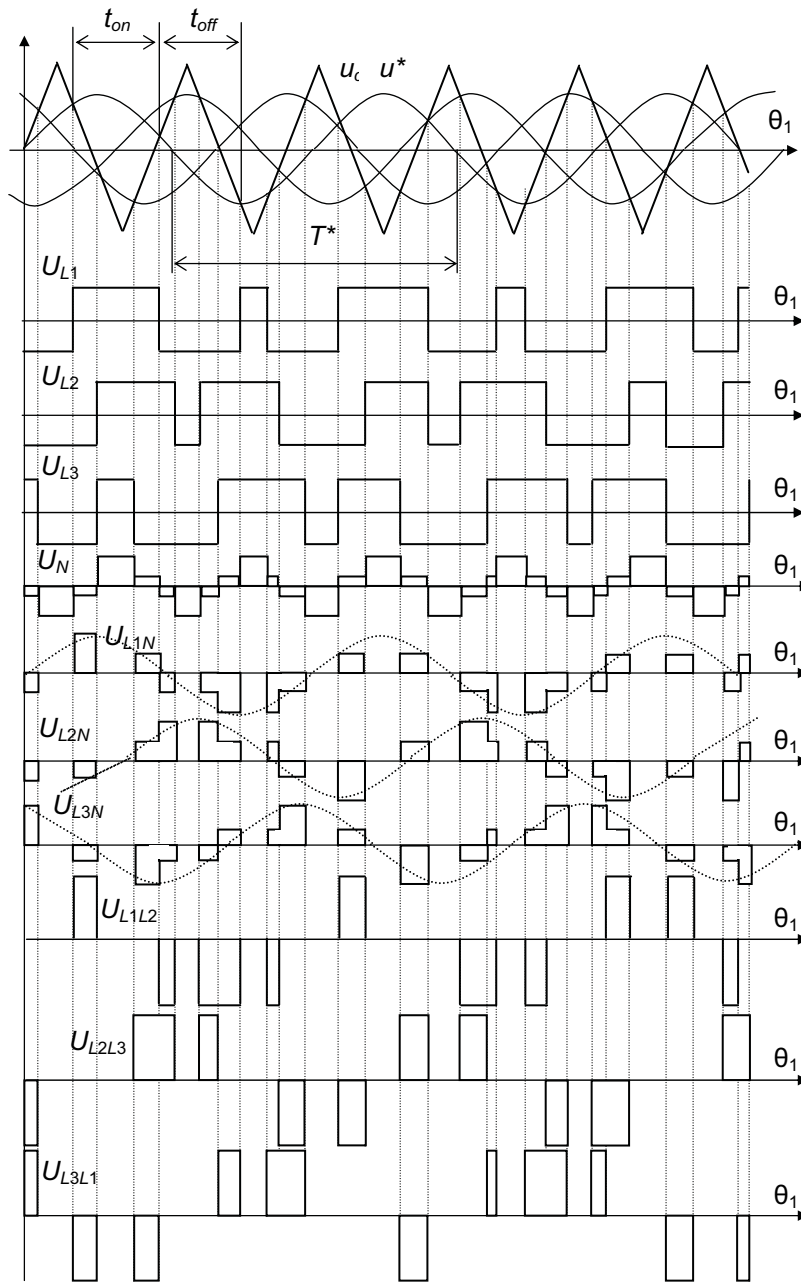

Fig. 52

Changing the pulse width of each half-cycle alters the output phase voltages  $U_{L1}$ ,  $U_{L2}$ ,  $U_{L3}$  of the inverter (with respect to mid dc link point). They are switched between positive and negative buses at the intersections of the carrier wave and the modulating waves. Here, unlike the block modulation scheme, the conduction angle  $t_{on}$  of various transistors may be less than  $60^\circ$ .

The sequence of switching has no order as in the block modulation case, and zero states are used regularly that correspond to zero load voltage. When **VT1** switches on, the load

phase  $L1$  is connected to the positive terminal of dc supply making  $U_{L1} = \frac{k_{mod}U_d}{2}$ . When **VT4** switches on, the phase  $L1$  is connected to the negative terminal of dc supply resulting in  $U_{L1} = -\frac{k_{mod}U_d}{2}$ . Waveforms of  $L2$  and  $L3$  are the same as those of  $L1$ , except that they are shifted.

Again, as for the block modulation, for the balanced three-phase operation described by (3) the voltage of the load neutral can be expressed by (4).

The load neutral voltage has three times the referred frequency and thus contains the triple harmonics, which does not appear in the load phase voltages that may be obtained from (5). Therefore, each phase obtains the voltage equal to  $\pm \frac{k_{mod}U_d}{3}$ ,  $\pm \frac{2k_{mod}U_d}{3}$ , or zero. Again, they have a characteristic six-stepped wave shape. The rms line-to-neutral voltage equals

$$U_N = \frac{k_{mod}U_d}{2}$$

## American online

# LIGS University

is currently enrolling in the  
Interactive Online **BBA, MBA, MSc,**  
**DBA and PhD** programs:

- ▶ enroll **by September 30th, 2014** and
- ▶ **save up to 16%** on the tuition!
- ▶ pay in 10 installments / 2 years
- ▶ Interactive Online education
- ▶ visit [www.ligsuniversity.com](http://www.ligsuniversity.com) to find out more!

Note: LIGS University is not accredited by any nationally recognized accrediting agency listed by the US Secretary of Education. More info [here](#).



that is the same as in the case of the six-step modulation when  $k_{mod} = 1$  and may exceed this value in the case of overmodulation. The corresponding line voltages of the load are given by (6).

Note that the positive pulse patterns of the voltages are not quite the same as the negative ones until  $f_c \neq 6kf^*$  with any integer  $k$ , although the two areas are quite similar to give zero average values. Fourier analysis of the inverter voltage waveforms reveals that they have less harmonic content than a single pulse per half-cycle inverter block-modulated voltage. Nevertheless, they have sinusoidal fundamental components but still noticeable losses as well as objectionable noise emitted by the converter and the load.

Increasing of  $k_f$  and  $k_{mod}$  leads to more symmetrical output waveforms with less losses and better harmonic contents, as Fig. 53 shows.

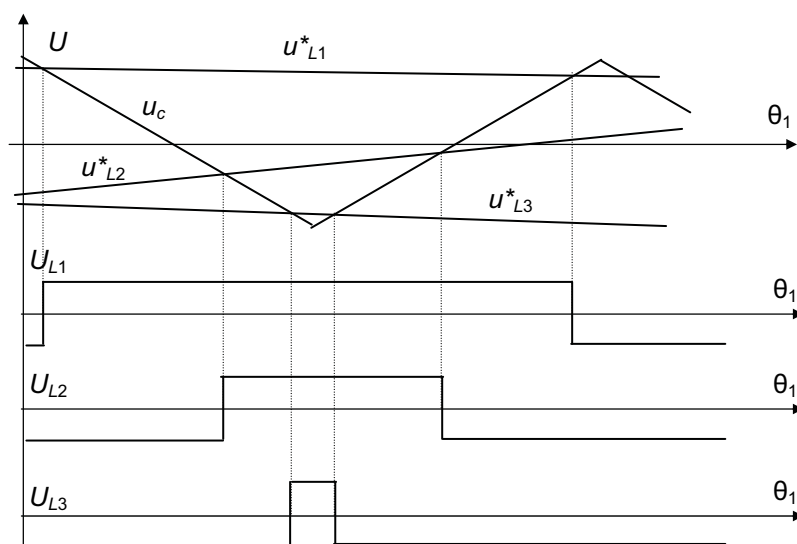

Fig. 53

**PWM gating.** The modulation frequency that a PWM system can theoretically process is the Nyquist frequency, thus the carrier rate is to be more than twice the Nyquist frequency. So far as in practice the carrier frequency must exceed the Nyquist level tenfold and more, the digital on-chip modulation sub-processors are employed for this purpose. Their goal is to generate the triangle carrier function  $u_c$ , compare it with one or three reference signals  $u^*$ , and find the logical results of this operation, as Fig. 51, *a* shows. The driver switches on the required transistor when  $u^* > u_c$ , and switches it off in the opposite case.

Clearly, the “analog” solution obtained by the intersection of a triangle wave and a sine wave becomes only one of many possibilities. There are numerous software-based modulation approaches based on the fast signal processors with unlimited flexibility ensured by combining

PWM and a sophisticated current control, such as predictive or time-optimal control. Particularly, this is of interest with high power converters switching at a lower frequency.

Often, the *natural modulation* earlier described is replaced to benefit from the advantage of *regular modulation* in which the modulating waveform is piecewise constant, particularly sampled at four of the carrier frequency.

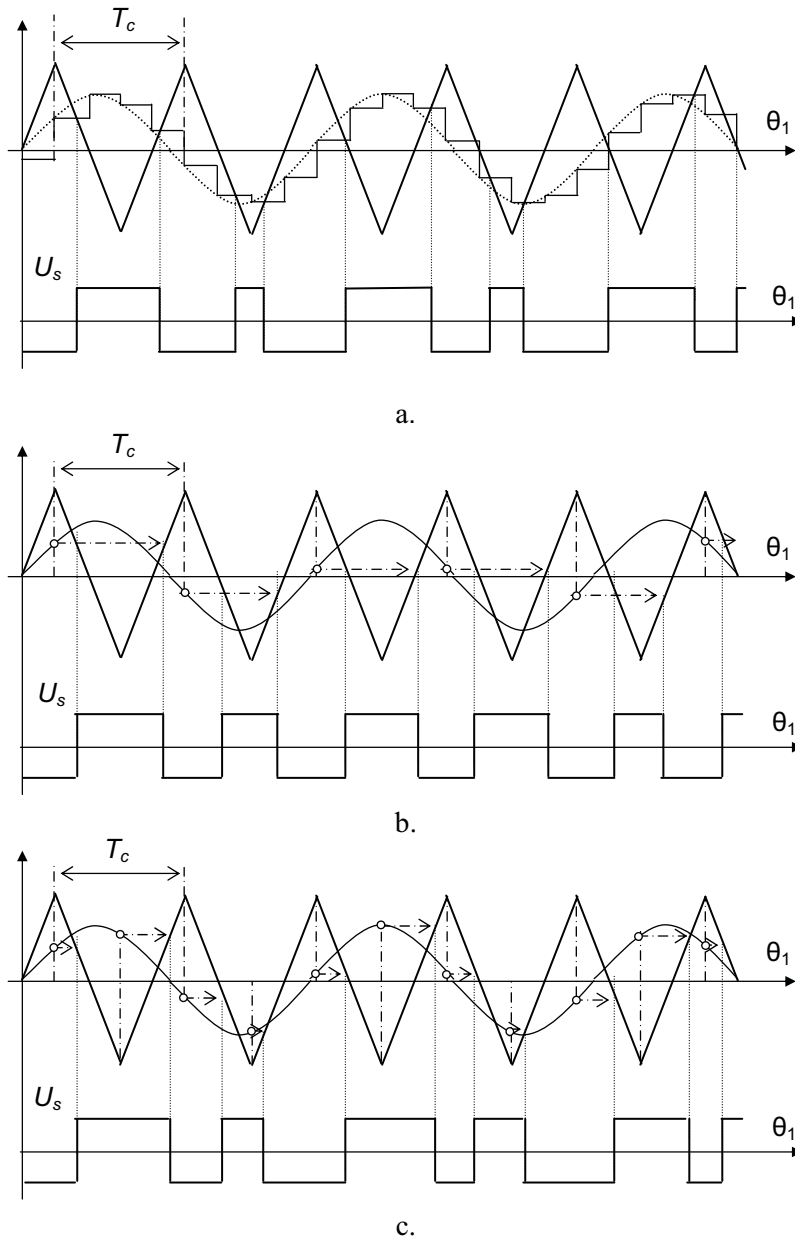

Fig. 54

In Fig. 54, *a*, representing a modulation process, one possible use of a microprocessor technique is introduced. The stepped *Euler interpolation* is displayed in this case.

To speed up this operation, one calculation per carrier period  $T_c$ , the real triangle function may be replaced by the *symmetrical interpolation* procedure illustrated in Fig. 54, *b*:

$$t_{on} = \frac{T_c}{4} \left( 1 + \frac{u^*}{u_c} \right)$$

$$t_{off} = t_{on} + \frac{T_c}{2}$$

An *asymmetrical interpolation* procedure is suitable as well. The graphs of voltages versus time shown in Fig. 54, *c*, help to understand this method. Thanks to the double frequency measurement, the dynamic modulation precision rises and the load current distortion decreases here, although the higher processor capacity is required.

All the described interpolation algorithms represent signals sufficiently accurately most of the time, but are limited by the bandwidth and the sample rate. They sample the signals in evenly spaced spans to construct the waveform; however, rapid variations that may occur between samples are not acquired. This glitch can result in aliasing, causing loss of important points. Other interpolation methods have been developed that find the highest and lowest values of the modulating signal over each sample interval and use these values



**e-learning for kids**

- The number 1 MOOC for Primary Education
- Free Digital Learning for Children 5-12
- 15 Million Children Reached

**About e-Learning for Kids** Established in 2004, e-Learning for Kids is a global nonprofit foundation dedicated to fun and free learning on the Internet for children ages 5 - 12 with courses in math, science, language arts, computers, health and environmental skills. Since 2005, more than 15 million children in over 190 countries have benefitted from eLessons provided by EFKI. An all-volunteer staff consists of education and e-learning experts and business professionals from around the world committed to making difference. eLearning for Kids is actively seeking funding, volunteers, sponsors and courseware developers; get involved! For more information, please visit [www.e-learningforkids.org](http://www.e-learningforkids.org).

in gating. In this way, the modulation system can process narrow pulses and corners, which may otherwise be missed. Of course, noise will appear to be higher in this approach.

PWM inverter efficiency typically approaches 98 % but this figure is heavily affected by the choice of the switching frequency – with low frequency, converter losses are low, while for higher switching frequency, the losses are higher.

To counterbalance these advantages, the switching frequency is variable and very intensive in such circuits; the number of switching per period is as high as  $\frac{2}{k_f}$ . As a result, the converter losses are higher than for the block mode of operation. When  $f_c \neq 6kf^*$ , the phase voltages are asymmetrical, therefore the bipolar modulation leads to the high current pulsation and the high reactive energy level.

An attempt to synthesize the best possible sine wave by selecting a higher carrier frequency may well create more losses in the inverter than in the load.

**Picket PWM.** *Picket PWM* is the type of PWM that is closest to the block modulation. Instead of varying the amplitude of the motor voltage waveform by the variation of the dc link voltage, it is changed by switching of one or two inverter transistors at the fixed pulse durations. These durations are called here the carrier periods that adjust the notches of the resulting pulses to control the load voltage in accordance with the referenced output level. The number of pulses is maintained constant over a predetermined speed range although the number of pulses may change discretely at several prescribed speeds. A simple timing diagram of the picket three-phase modulation is shown in Fig. 55 where the switching is limited by the middle  $60^\circ$  of each device conduction period, resulting in a minimum switching duty of the semiconductor switches. In spite of the similarities between the picket modulation and the block mode, motor torque pulsations at low speed are much less severe than for the six-step modulated inverter. The harmonics typical of the six-step inverter are represented also with picket modulation, but there are also higher harmonics associated with the switching frequency. However, the motor noise and losses are significant compared to more elegant modulation algorithms, thus this method is not widely used.



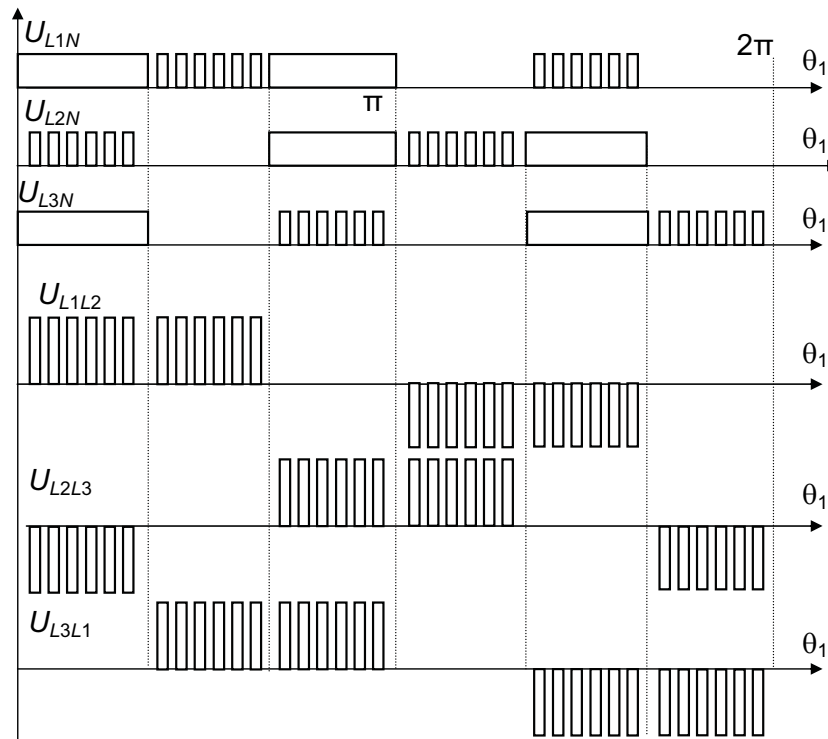

Fig. 55

**Summary.** PWM is a basic energy processing technique applied in modern power converter systems. When the sinusoidal PWM is used, the low-order voltage harmonics are greatly attenuated although other significant harmonics are represented close to the carrier frequency. Hence, this is a good solution where an electronic system is to be used across a wide voltage and frequency range. Since voltage and frequency are both controlled with the PWM, a quick response to changes in the demand voltage and frequency can be achieved.

At the same time, PWM inverters have several problems in terms of ac motors. Often, harmonics of output voltage increase the loss of the motor, and spikes caused by the high  $\frac{dU}{dt}$  have a serious effect on motor insulation. In addition, PWM inverters generate high frequency voltage, which may increase the bearing current of the ac motor and equipment connected by the shaft. The bearing current generates noises and breaks the bearings of equipment in severe cases. High  $\frac{dU}{dt}$  of the inverter output is reflected in the cable, which may cause the motor terminal voltage to increase up to double of the voltage step. This peak voltage depends on the value of  $\frac{dU}{dt}$  of the inverter output voltage and the cable length. Therefore, different filters are attached to the inverter output to reduce the peak voltage.



## 2.4 SPACE VECTOR MODULATION

**Objective.** The unsatisfactory noise situation has given rise to the development of a multitude of advanced modulation. Their objective is to reduce the current harmonics of power losses, the current pulsations or noise under steady-state conditions as well as to avoid the continued fluctuations of the voltage amplitude, which would disturb the switching sequences.

There are a number of circuits where the fine and rapid control is obtained through the frequency input of the modulator but the voltage would be changed more slowly and temporarily in somewhat coarser steps. Clearly, the more often the voltage is reversed per period, the more conditions can be satisfied, given a precision fundamental voltage component.

The restrictions of the converter with regard to the minimum time between two subsequent switching operations must be observed to allow the commutation to be completed. In addition, the losses in the converter caused by each commutation transient should be considered, which means that there is an upper limit for the switching frequency.

A very effective method that is particularly suited for the fast switching converters is called *space vector modulation (SVM)* or *vectorial PWM* because it represents an attempt to reproduce a voltage vector demanded by a controller in a given time interval. It is a digital technique



.....Alcatel-Lucent 

[www.alcatel-lucent.com/careers](http://www.alcatel-lucent.com/careers)

What if you could build your future and create the future?

One generation's transformation is the next's status quo. In the near future, people may soon think it's strange that devices ever had to be "plugged in." To obtain that status, there needs to be "The Shift".

of building the load voltages, which are on average as near as possible to a given value. The objective of this method is to minimize the switching frequency to reduce unwanted even harmonics in the output voltage spectrum. This is done in each sampling period by properly selecting the switch states from the valid variants presented in the look-up table and by carefully calculating the period of times they are used. The selection and calculation times are based upon the space-vector transformation, where the reference voltage is treated directly but not phase-by-phase. Like the block modulation algorithm and sinusoidal PWM, this method provides all the possible switching states made up of the six-step block control system.

**Space vectors graph.** To proceed from the six-step modulation to SVM, associate each binary word of the table shown in Fig. 50 with a particular *space vector* and describe the switching states of the converter by eight space vectors  $U_0 \dots U_7$ . This vector set includes six *active voltage space vectors*  $U_1$  to  $U_6$  corresponding to the switching states 100, 110, 010, 011, 001, 101, and two *zero voltage space vectors*  $U_0$ ,  $U_7$  keeping with 111 and 000.

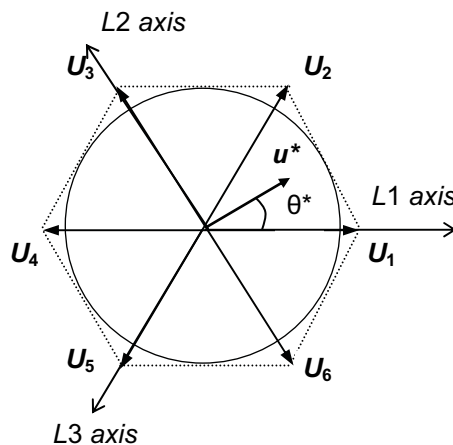

Fig. 56

On the plane shown in Fig. 56 (known also as the Concordia graph), six active space vectors are situated  $60^\circ$  apart, segmenting the plane by equal sectors. Voltage vectors  $U_1$ ,  $U_3$ ,  $U_5$  are oriented along the axes of  $L1$ ,  $L2$ , and  $L3$  phases. Supply voltage  $U_d$  specifies the amplitude of the space vectors. The demanded reference vector is determined by its module  $u^*$  and phase  $\theta^*$ . Allowable module of the reference vector for each of an angle is

$$u_{\max}^* = \frac{U_d}{\sqrt{3}}$$

Since  $u^*$  is normally not coinciding with one of the available space vectors its allowable phase is

$$\theta_{\max}^* = \frac{\pi}{3}.$$

**Control method.** In SVM, the reference voltage space vector  $\mathbf{u}^*$  is treated through adequate timing of adjacent non-zero and zero space vectors. It is composed by a switching sequence comprising the neighbor space vectors  $\mathbf{U}_1 \dots \mathbf{U}_6$ , while filling up the rest of the time interval with zero vectors  $\mathbf{U}_0$  or  $\mathbf{U}_7$  during the voltage alternation. Again, as Fig. 50 shows, during one transition, only one pair of the switches changes its state: **VT2** with **VT5**, **VT1** with **VT4**, or **VT3** with **VT6**. As a result, the end of vector  $\mathbf{u}^*$  travels along the hexagon or stops. Deviation of the vector end from the circle causes the voltage and current distortions.

Timing the eight voltage space vectors  $\mathbf{U}_0 \dots \mathbf{U}_7$  is, in fact, the art of SVM. Let the modulation period  $2\pi$  consists of six sub-intervals, each including a number of fixed carrier intervals:

$$T_c = \frac{2\pi f^*}{f_c} = \frac{2\pi}{k_f}$$

Then, to obtain a reference vector  $\mathbf{u}^*$  situated between the neighbor vectors  $\mathbf{U}_i$  and  $\mathbf{U}_{i+1}$ , the switching sequence of pulses  $U_i$  and  $U_{i+1}$  has to be generated in each carrier interval, the time durations of which are consequently  $t_i$  and  $t_{i+1}$ , that is

$$\mathbf{u}^* = f_c (t_i \mathbf{U}_i + t_{i+1} \mathbf{U}_{i+1}),$$

where  $\mathbf{U}_i$  is one of the space vectors;  $\mathbf{U}_{i+1}$  is the space vector valid in the next  $T_c$  interval;  $t_i$  and  $t_{i+1}$  are the sub-intervals for the two adjacent vectors that are to be computed in real time. Minimum values of  $\mathbf{u}^*$  and  $t_i$  are zero whereas their maximum values are  $\mathbf{u}^*_{\max}$  and  $T_c$ . Commonly,

$$t_i + t_{i+1} + t_0 = T_c,$$

where  $t_0$  is the zero vector duration. Solution for  $t_i$  and  $t_{i+1}$  results in

$$t_i = \frac{\sqrt{3}u^*}{2U_d} T_c \sin\left(\frac{\pi}{3} - \theta^*\right)$$

$$t_{i+1} = \frac{\sqrt{3}u^*}{2U_d} T_c \sin \theta^*$$

Since  $t_i$  and  $t_{i+1}$  are calculated, the residual sampling time is reserved for zero vectors:

$$t_0 = T_c - t_i - t_{i+1}$$

In fact, this technique produces an average of three voltage space vectors  $U_p$ ,  $U_{i+1}$ , and  $U_0$  ( $U_7$ ) over a carrier interval  $T_c$ . Particularly, the maximum value of  $u^*$  without delays (when  $t_0 = 0$ ) may be calculated from these equations as follows:

$$u^* = \frac{2U_d}{\sqrt{3}T_c \left( \sin\left(\frac{\pi}{3} - \theta^*\right) + \sin\theta^* \right)}$$

In each sector, it describes the straight line, which is the side of the hexagon that connects the ends of space vectors. Taking the sector altitude as the maximum space vector modulus  $u^*_{\max}$ , we obtain the inscribed circle as the optimum switching path. Thus, using SVM leads to the output voltage amplitude equal to the inner-circle radius of the hexagon, that is  $\frac{U_d}{\sqrt{3}}$  or 15.5% higher than in the case of sinusoidal PWM with  $k_{\text{mod}} = 1$ . This means also that in any case except for  $\frac{k\pi}{3}$  ( $k = 1 \dots 6$ ), the zero space vectors should take part in switching. Thus, to control the average modulus of the space vector (output voltage pausing) extra switching is required in addition to that indicated in the switching table.



**Maastricht University**

*Leading in Learning!*

**Join the best at  
the Maastricht University  
School of Business and  
Economics!**

**Top master's programmes**

- 33<sup>rd</sup> place Financial Times worldwide ranking: MSc International Business
- 1<sup>st</sup> place: MSc International Business
- 1<sup>st</sup> place: MSc Financial Economics
- 2<sup>nd</sup> place: MSc Management of Learning
- 2<sup>nd</sup> place: MSc Economics
- 2<sup>nd</sup> place: MSc Econometrics and Operations Research
- 2<sup>nd</sup> place: MSc Global Supply Chain Management and Change

Sources: Keuzegids Master ranking 2013; Elsevier 'Beste Studies' ranking 2012; Financial Times Global Masters in Management ranking 2012

**Maastricht University is the best specialist university in the Netherlands (Elsevier)**

**Visit us and find out why we are the best!  
Master's Open Day: 22 February 2014**

[www.mastersopenday.nl](http://www.mastersopenday.nl)



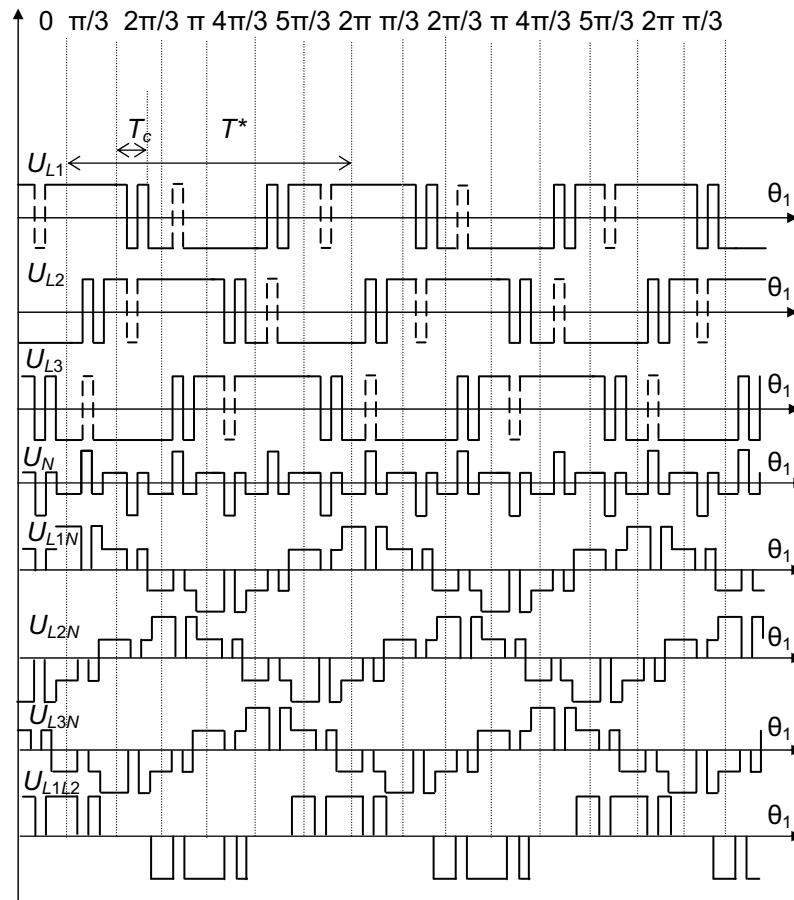

Fig. 57

An example of the SVM operation diagram is shown in Fig. 57. Here, the additional pulses that perform zero space vectors are shown by strokes. The most popular SVM method is modulation with symmetrical zero states when the durations of  $U_0$  and  $U_7$  are equal  $0,5t_0$ . In the diagram,

- in the sectors  $0 \dots 60^\circ$  and  $180^\circ \dots 240^\circ$ , VT1 and VT4 preserve their states, VT2 and VT5 switch periodically to move the space vector along the circle, and VT6 is replaced momentarily by VT3 to produce the zero voltage vector;
- in the sectors  $60^\circ \dots 120^\circ$  and  $240^\circ \dots 300^\circ$ , VT3 and VT6 preserve their states, VT1 and VT4 switch periodically to move the space vector along the circle, and VT2 is replaced momentarily by VT5 to produce the zero voltage vector;
- in the sectors  $120^\circ \dots 180^\circ$  and  $300^\circ \dots 360^\circ$ , VT2 and VT5 preserve their states, VT3 and VT6 switch periodically to move the space vector along the circle, and VT4 is replaced momentarily by VT1 to produce the zero voltage vector.

It is beneficial to compare the SVP timing diagram with analogous diagrams of the block modulation and sinusoidal PWM discussed earlier.

Obviously, the zero voltage timing distorts the output waveform along with the reference voltage decreasing. To further smooth transition and improve performance, special overmodulation algorithms are introduced.

The above given equations describe an idealized situation, where the intervals and the inherent delays of the switching devices are neglected. For the actual design of modulators, these effects must be taken into account, particularly the difference between turn-on and turn-off times, which can cause considerable distortion of the converter characteristics at low output voltage and frequency.

**Summary.** SVM produces higher performance although it can be implemented only on microprocessors because it requires online computation of the referenced voltage space vector.

As compared to the block modulation and sinusoidal PWM, SVM allows a higher phase voltage and thus a higher output power of a converter with minimum switching frequency. The output voltage amplitude in the sinusoidal PWM is near  $\frac{U_d}{2}$ . With the space vector PWM, the amplitude is equal to the inner-circle radius of the hexagon that is  $\frac{U_d}{\sqrt{3}}$  or 15.5% higher. However, this is achieved through abandoning the sinusoidal output that results in additional losses caused by higher harmonic components.

Furthermore, with a diode rectifier as the input circuit, a high power factor, approaching unity, is offered to the incoming ac supply over the entire voltage and load range. No PWM generation is needed here and the modulation does not depend on the load parameters. Typically, it is a very robust signal processing method where quick and precise control response is achieved.

Thus, this technique is well suited for the high-performance high-speed applications.

# INDEX

## A

- amplifier 79
- angle
  - firing 23
  - of advance 23
  - overlap 23
  - phase displacement 20

## B

- bipolar junction transistor 15
- boosting 69

## C

- changer 48
- characteristics
  - control 64
- chopper 61
  - boost 61
  - brake 59
  - buck 61
  - fly-back 61
  - forward 61
  - step-down 61
  - step-up 61
- circuit
  - anti-parallel 86
  - sensing 64
- control
  - coordinated 87
  - joint coordinated 88
  - joint non-coordinated 89
  - separate 86
- converter 10
  - AC/AC 48
  - AC/DC 18
  - buck-boost 73
  - Cuk 74
  - cyclo- 48
  - DC/AC 31
  - DC/DC 61
  - dc link 48

- diagonal half-bridge 67
- direct frequency 48
- double-ended forward 67
- forced commutated 18
- forward 65
- four-quadrant 25
- half-bridge asymmetrical 67
- line-commutated 18
- matrix 53
- push-pull 69
- PWM 104
- single-quadrant 22
- transformer-isolated 66
- two-quadrant 23
- two-switch forward 67
- current 21
  - continuous 82
  - discontinuous 22

## D

- diac 13
- diagram
  - circuit 19
  - control 81
  - operation 79
  - output 84
  - timing 79
- diode 12
  - feedback 32
  - freewheeling 32
- driver
  - gate 79
- duty cycle 64

## E

- EMC 27

## F

- factor
  - ripple 20
- feedback 79
- firing angle 13



- frequency
  - chopping 64
- G**
- gate turn-off thyristor 14
- gating 78
- gear changing 106
- generator
  - carrier 79
- I**
- insulated gate bipolar transistor 16
- interpolation
  - asymmetrical 111
  - Euler 110
  - symmetrical 111
- inverter 31
  - autonomous 32
  - current source, CSI 32
  - line-fed 32
  - offline 32
  - online 32
  - PWM 104
  - resonant 43
  - voltage source, VSI 32
  - voltage stiff 32
  - Z- 37
- J**
- junction field-effect transistor 15
- L**
- loose running 66
- M**
- metal-oxide semiconductor field-effect transistor 15
- mode
  - circulating current 87
  - circulating current-free 89
- modulation 79
  - bipolar voltage-switching 105
  - block 79
  - index 106
  - natural 110
  - phase 79
  - phase-shift 92
  - picket 112
  - PWM 104
  - rectangle 79
  - regular 110
  - sinusoidal 104
  - six-step 100
  - space vector 114
  - square-wave 79
  - vectorial 114
- MOS-controlled thyristor 14
- O**
- overmodulation 106
- P**
- power electronics 9
- power electronic system 10
- R**
- ratio
  - carrier 106
  - duty 64
  - frequency 106
  - modulation 106
- rectifier 18
  - active 28
  - bridge 23
  - controlled 19
  - dual 25
  - full-wave 23
  - half-wave 22
  - midpoint 23
  - passive 18
  - PWM 104
  - three-phase 24
  - uncontrolled 19
  - Vienna 29
- regulator 61
  - boost 72
  - buck 64
  - buck-boost 74
- resistor
  - braking 59

**S**

- sampling 80
- shoot-through 37
- signal
  - carrier 79
  - modulation 79
- space vector 115
  - active 115
  - zero 115
- switching
  - hard 43
  - soft 43
  - table 102
  - Zero Current 43
  - Zero Voltage 43

**T**

- thyristor 13
- triac 14

**V**

- voltage 21