

An-Najah National University  
Faculty of Graduate Studies

**Design and Building of Biogas Digester for  
Organic Materials Gained From Solid waste**

By  
Mansour-Al Sadi

Supervisor  
Prof.Dr. Marwan Mahmoud

*This Thesis is submitted in Partial Fulfillment of the Requirements for the Degree of Master of Program in Clean Energy and Conservation Strategy Engineering, Faculty of Graduate Studies, An-Najah National University, Nablus-Palestine.*

**2010**



A handwritten signature in blue ink, appearing to be "M. Al Sadi".

## Design and Building of Biogas Digester For Organic Materials Gained From Solid Waste

By  
Mansour-Al Sadi

Supervisor  
Prof. Dr. Marwan Mahmoud

This Thesis was defended successfully on 4/2/2010, and approved  
by:

Defense Committee Members

Signature

1. Prof. Dr. Marwan Mahmoud (Supervisor)

A handwritten signature in blue ink, corresponding to Prof. Dr. Marwan Mahmoud, written over a dashed line.

2. Dr. Osama Omari (External Examiner)

A handwritten signature in blue ink, corresponding to Dr. Osama Omari, written over a dashed line.

3. Dr. Muneer Abdo (Internal Examiner)

A handwritten signature in blue ink, corresponding to Dr. Muneer Abdo, written over a dashed line.

## **Dedication**

**Dedicated to.....**

**My Family For Constant Love and Support**

## **Acknowledgments**

**I would like to thank Prof. Marwan Mahmoud my major professor and advisor, for his continuous support, guidance and encouragement. He has been the source of continuous support and help through out my Master's degree program.**

**I will never forget what I have learned from Prof. Marwan Mahmoud to do researches in a scientific way with full confidence and hopefulness.**

**I would like to thank my family for constant love and support that have always give me.**

**Finally , I would like to thank my friends at Nablus Industrial School for support that have given me.**

**Mansour Al - Sadi**

## الإقرار

أنا الموقع أدناه مقدم الرسالة التي تحمل العنوان:

# Design and Building of Biogas Digester for Organic Materials Gained From Solid Waste

## تصميم وبناء هاضم حيوي لإنتاج الغاز من النفايات الصلبة

أقر بأن ما اشتملت عليه هذه الرسالة إنما هي نتاج جهدي الخاص، باستثناء ما تمت الإشارة إليه حيثما ورد، وان هذه الرسالة ككل، أو أي جزء منها لم يقدم من قبل لنيل أية درجة علمية أو بحث علمي أو بحثي لدى أية مؤسسة تعليمية أو بحثية أخرى.

### Declaration

The work provided in this thesis, unless otherwise referenced, is the researcher's own work, and has not been submitted elsewhere for any other degree or qualification.

**Student's name:**

اسم الطالب: منصور علي سليمان السعدي

**Signature:**

التوقيع:

**Date:**

التاريخ: 4/02/2010

## Abbreviations

AD	Anaerobic Digestion
AC	alternating current
B	barrel
BSP	Biogas Support Program
C <sub>4</sub> H <sub>10</sub>	Butane gas
CH <sub>4</sub>	Methane gas
C/N	Carbon : Nitrogen ratio
CO <sub>2</sub>	Carbon dioxide gas
CH <sub>4</sub>	Methane Gas
CHP	Combined Heat and Power
D1	1.5 m <sup>3</sup> digester with stirrer
D2	1.5 m <sup>3</sup> digester without stirrer
DC	direct current
h	Height [m]
H <sub>2</sub>	Hydrogen gas
HRT	Hydraulic Retention Time
GHG	Green House Gases
kg	Kilo gram
km	Kilo meter
kj	Kilo Joule
kWh	Kilo. Watt. Hour
L	litter
LPG	Liquefied petroleum gas
m	meter
MSW	Municipal Solid Waste
mg	milligram
NMOCs	"non-methane organic compounds"
N <sub>2</sub>	Nitrogen gas
NIS	New Israeli Shekel
NGO	Non Governmental Organization
OFMSW	Organic fraction of Municipal Solid Waste
OLR	Organic Loading Rate
PERC	Palestinian Energy and Environment Research Center
pH	Acidity degree value
PVC	Polyvinyl chloride
PV devices	Photovoltaic
ERC	Energy Research Centre at An-Najah National University
r	Radius [m]
RAS	Return Activated Sludge

SRT	Solids Retention Time
TS	total solids
T <sub>a</sub>	Auto ignition temperature [°C]
T <sub>b</sub>	Boiling point [°C]
T <sub>f</sub>	Flash point [°C]
T <sub>m</sub>	Melting point [°C]
t	Retention time [day]
UASB	Up flow Anaerobic Sludge Blanket
V	Volume [m <sup>3</sup> ]
VFAs	Volatile fatty acids
Z.A	Zahret Alfingan Landfill
ρ	Density [kg/m <sup>3</sup> ]

### Term Definition

**Anaerobic Digestion: (AD)** the biological, physical and or chemical breakdown of animal manure in the absence of oxygen.

**Biogas:** the gas produced as a by-product of the anaerobic decomposition of livestock manure consisting of about 60-80 percent methane, 30-40 percent carbon dioxide, and trace amounts of other gases.

**Combined Heat and Power: (CHP)** a system for producing electricity while capturing and using heat.

**Hydraulic Retention Time :(HRT)** average length of time any particle (liquid or solid) of manure remains in a manure treatment or storage structure.

**Mesophilic :**Relating to, or being at a moderate temperature of about 30 to 35 c degrees.

**Return Activated Sludge:(RAS)** a process by which some of the digester bacteria are returned to the digester reducing the amount of energy.

**Solids Retention Time: (SRT)** average length of time any solid particle of manure remains in a manure treatment or storage structure. This is calculated by the quantity of solids maintained in the digester divided by the quantity of solids wasted each day.

## Table of Contents

No.	Content	Page
	Dedication	II
	Acknowledgments	III
	Declaration	IV
	Abbreviations	V
	Table of contents	VII
	List of tables	X
	List of figures	XI
	Abstract	XIII
<b>Chapter One: Introduction and Background</b>		<b>1</b>
1.1	Introduction and Background	2
1.2	Definitions and History	4
1.3	Research Questions	6
1.4	Research Objectives and Outputs	6
1.5	Literature Review	6
<b>Chapter Two:</b>		<b>9</b>
<b>A- Renewable Energy Sources and the Environment</b>		
<b>B- Potential of a Renewable Energy in Palestine</b>		
2.1	What Is Energy?	10
2.2	Renewable Energy Sources and the Environment.	10
2.3	Potential of Renewable Energy in Palestine.	16
<b>Chapter Three: Municipal Solid Waste, Landfill Gas, Biogas, Biofuels</b>		<b>23</b>
3.1	Municipal Solid Waste.	24



No.	Content	Page
3.2	Burning Municipal Solid Waste (MSW).	24
3.3	Facts about Landfill Gas	24
3.4	Collecting Landfill Gas or Biogas	25
3.5	Biodegradation	26
3.6	Bioreactors Landfills	27
3.7	Landfill Energy	28
3.8	Anaerobic Treatment	28
3.9	Bio fuels	29
3.10	Biogas.	29
<b>Chapter Four: Biogas Generation</b>		33
4.1	Biogas Technology in the World.	34
4.2	Anaerobic Digestion	37
4.3	Biological and Chemical Oxygen Demand	40
4.4	Basic Digester Design	41
4.5	Available Feed stocks for AD	46
4.7	Factors Affect the Rate of Digestion and Biogas Production	48
4.8	Biogas Plants Types	56
4.9	Size types	57
4.10	Design types	58
4.11	Inputs and Their Characteristics	61
<b>Chapter Five: Potential of Biogas Production In Palestine</b>		63
5.1	Potential of Biogas Production in Palestine	64
5.2	Theoretical Estimation of Biogas Production in North of West Bank	64
5.3	Constructed digesters in Palestine	65

No.	Content	Page
<b>Chapter six: Experimental Work</b>		72
6.1	Experimental Work	73
6.2	Experimental work on daily feed digester	73
6.3	Experimental Work With Batch System in Nablus Industrial School	80
6.4	Case Study: Jenin Digester At Zahret AL-Fingan Land Fill	85
6.5	Why Anaerobic Digestion?	87
6.6	Methane Production	89
6.7	Assumed Values	89
6.8	Discussion of Results	90
<b>Chapter Seven: Design of a Family Digester and Its Economic Evaluation</b>		92
7.1	Family Digester Design and Its Economic Evaluation	93
7.2	Daily Feed Quantity as Continuous Feed Type	95
7.3	Batch system	95
7.4	The family digester design	96
7.5	Economic Analysis	97
	Conclusion	99
	Recommendations	100
	References	101
	Appendix	105
	الملخص	116

### List of Tables

No.	Table	Page
Table (2.1)	The daily average of total solar radiation and wind speed for each month during 2000 at Jenin	17
Table (3.1)	Biogas composite	31
Table (3.2)	Characteristics for CH <sub>4</sub>	31
Table (3.3)	Characteristics of different fuel gases	32
Table (4.1)	Problems with pH value	49
Table (4.2)	C/N ratio of some organic materials	51
Table (4.3)	Effects of C/N ratio	52
Table (4.4)	Toxic level of various inhibitors	56
Table (4.5)	Gas production potential of various types of dung	62
Table (4.6)	The gas yield of some common fermentation materials	62
Table (5.1)	composition of each digester sample with ratio of each organic waste type and water dilution factor are found	66
Table (5.2)	Approximated areas and amount of biogas production from one Kg waste for some of Jenin digesters	69
Table (6.1)	Mansour digester results	76
Table (6.2)	Best Result	79
Table (6.3)	N.I.S digester result	83
Table (7.1)	Requirements and costs for constructing the family design	97

### List of Figures

No.	Figure	Page
Figure (2.1)	Types of Biomass	14
Figure (2.2)	Meteorological station used by the Energy Research Centre at An-Najah National University	18
Figure (2.3)	Yearly averages solar radiation in different cities in Palestine	18
Figure (2.4)	The carbon cycle	20
Figure (3.1)	biogas energy if use as car fuel	25
Figure (3.2)	Modern landfill	28
Figure (4.1)	Rubber top digesters	36
Figure (4.2)	Anaerobic process microbiology consists of four steps	37
Figure (4.3)	Path of Anaerobic Digestion	40
Figure (4.4)	Continuous digester	44
Figure (4.5)	Electricity output per M.T	47
Figure (4.6)	Concrete model biogas plant	59
Figure (4.7)	Deenbandhu biogas plant (3m <sup>3</sup> gas production per day)	59
Figure (4.8)	Bag digester	60
Figure (4.9)	Plug flow digester	60
Figure(4.10)	The anaerobic filter	61
Figure (5.1)	PH values with time for the samples from B1 to B10	67
Figure (5.2)	PH values with time for the samples from B11 to B18 and D1, D2 [24].	67
Figure (5.3)	Biogas productions with time for Barrels from B1 to B10	67
Figure (5.4)	Biogas productions with time for Barrels from B11 to B18	68
Figure (5.5)	Biogas productions with time for Barrels for D1 and D2	68
Figure (5.6)	Biogas production rate m <sup>3</sup> for 50 L slurry per day for Khadoury digester	69

<b>Figure (5.7)</b>	Biogas production rate $m^3$ for 100 L slurry per day for Khadoury digester	70
<b>Figure (5.8)</b>	The functional test measurements for daily rate production of biogas in Shufa digester ( $m^3/day$ )	71
<b>Figure (6.1)</b>	Mansour digester	73
<b>Figure (6.2)</b>	The result of the daily rate production of biogas	81
<b>Figure (6.3)</b>	The result of the daily ph record	81
<b>Figure (6.5)</b>	N.I.S Digester dimensions	84
<b>Figure (6.6)</b>	bio gas generation from Nablus Industrial school digester	88
<b>Figure (6.7)</b>	PH value from Nablus Industrial school digester	88
<b>Figure (7.1)</b>	Sketch of a family digester in Palestine ( $0.5 m^3$ ) Dimension in mm.	100

# **Design and Building of Biogas Digester for Organic Materials Gained From Solid Waste**

**By  
Mansour-Al Sadi**

**Supervisor  
Prof.Dr. Marwan Mahmoud**

## **Abstract**

There are millions of tons of biomass waste being produced every year for which disposal is a problem. At the same time the world is rapidly depleting its supply of natural gas, which is known to be the cleanest of the fossil fuels. Anaerobic digestion (AD) is a highly promising technology for converting biomass waste into methane, which may directly be used as an energy source, or converted to hydrogen. This thesis describes an alternative low cost approach to anaerobic digestion and energy production.

This thesis depends mainly on the organic materials gained from solid waste materials such as food, garden waste and paper.

This issue makes this thesis very different in comparison to those dealing with anaerobic digesters depending on animal dung.

The motivation for this study comes from Zahret.Alfinjan Landfill in Jenin City at north of West Bank. There is no heavy industry in the municipalities and no hazardous waste produced and thus is a good candidate for biological treatment.

From the calculations, a range of 4000 to 5000 kWh/day of electricity can be produced by the digester according to 400 ton/day received to Zahret

Alfingan land fill with organic fraction 50%, resulting enough power to supply 800 to 1000 homes of Jenin City.

This thesis will discuss the biogas production technology from organic waste using tow types of digestion:

Batch-load digesters are filled all at once, sealed, and emptied when the raw material has stopped producing gas, An experimental work in Nablus Industrial School, where we use a batch digester type with 100 liter capacity and we fill the digester by 30 kg of organic waste and 30 liter of water (total mix as liquid 60 liter), which produced 4.98 kg of bio gas over 30 days, as result we can say each one kg of organic waste can produce 0.166 kg of bio gas.

Another experimental work done on continuous-load digesters which feed a little, regularly, so this gas and fertilizer are produced continuously. A two drum digester continuous-load digesters with total volume of 240 L. We used about 100 kg of waste and 100 liter of water, with a daily supply of 5 L mixed over a period of 40 days, 11.125 kg of biogas during 40 days =  $15.89\text{m}^3$  had been produced, (density of Methane  $0.7\text{ kg/m}^3$ ). As result we can say each kg of organic waste can produce 0.11 kg of bio gas.

# **Chapter One**

## **Introduction and Background**



## 1.1 Introduction and Background.

Around the world, pollution of the air and water from municipal, industrial and agricultural operations continues to grow. The concept of the 'four R's', which stands for Reduce, Reuse, Recycle, and Renewable Energy, have generally been accepted as a useful principle for waste handling.

The emission of CO<sub>2</sub> and other greenhouse gases (GHG) has become an important issue, particularly since Russia has ratified the Kyoto Protocol which came into force on 16 February, 2005. Governments and industries are therefore increasingly on the lookout for technologies that will allow for more efficient and cost-effective waste treatment while minimising greenhouse gases .

The purpose of this thesis is to develop a design of an effective solids anaerobic digestion (SAD) system in West Bank.

In this thesis, a complete literature review of existing anaerobic digestion in general and High Solid Anaerobic Digestion (HSAD) technology in particular is presented.

Organic waste anaerobic digestion that will produce energy, recover fertilizer, and provide organic materials that could prove beneficial in composting and eventual use in creating high fertility soil for gardeners, and agriculture from organic municipal solid waste.

The existing technology will be compared according to reported performance, impacts and economics of full scale application. Modeling concepts of mixing and energy balance as crucial aspects of anaerobic digestion are also reviewed to highlight their importance and how they will be tackled in the future project tasks in West Bank.

This thesis will discuss the Biogas Production Technology from organic waste; It contains seven chapters to explain the process of biogas production systems and the potential of biogas production in Palestine.

The first chapter includes introduction and background, research question, research objectives, and literature review.

The second chapter divided into two parts; The first part shows the renewable energy sources in general; The second part shows potential of a renewable energy in Palestine, climate in Palestine, potential of Solar Energy in Palestine, potential of Wind Energy in Palestine, potential of Biomass Energy in Palestine, and Municipal Solid Waste in Palestine.

In the third chapter I give information about biofuels, biogas, biogas characteristics; Then, the chapter is concerning with biogas systems, their types and the main factors influencing the selection of the design. At the end of the chapter, try to classify and to discuss the characteristics of digester inputs.

In the fourth chapter, try to present the biogas generation in the World and in Arab countries it also contains the biogas resources, biogas process, and the important factors affected the digestion process.

In the fifth chapter, Try to present the potential of biogas Production in Palestine. It consists the Organic Wastes in Palestine and estimation of theoretical biogas production and constructed digesters in Palestine, Jericho Digester, Jenine Digester Plant, Khadoury digester/ Tulkarem, Shufa Digester.

In the sixth chapter, a case study includes an economic evaluation of biogas production for Zahret Al Fingan Land fill Digester by calculating

the cost of  $1\text{m}^3$  biogas related to experimental work which carried out at homes made digester as pilot digester.

In Chapter Seven, I discuss the design of a family digester and its economic evaluation, sizing the digester ,daily feed quantity as continuous feed type, batch system type, economic analysis, capital cost, running cost, biogas profit, fertilizer profit and finally Simple bay back period calculation.

## **1.2 Definitions and History.**

Digestion is a process by which organic material is dissolved and chemically converted so that it can be absorbed by the cells of an organism and used to maintain body functions. During digestion, these organic compounds are reduced by hydrolytic enzymes, such as cellulase, protease, and lipase, secreted by bacteria and glands. [1]

The process of anaerobic digestion (AD) employs specialized bacteria to break down organic waste, converting it into biogas, a mixture of Carbon Dioxide and Methane, and a stable biomass. [2]

Under anaerobic conditions, a considerable portion of the Chemical Oxygen Demand (COD) is converted to Methane gas as an end product. Methane is a potential energy source, thereby lessening the waste biomass disposal requirements and the financial burden associated with disposal considerably. Biogas produced from AD has been promoted as a part of the solution to energy problems. Methane contains about 90% of the energy with a calorific value of  $9000 \text{ kcal /m}^3$  ( $10.46 \text{ kWh/m}^3$ ) and can be burned on site to provide heat for digesters or to generate electricity. Little energy (3-5%) is wasted as heat in the biological process [3].

Recent developments in AD technology worldwide are in the treatment of industrial wastes and wastewater. The current designs of the AD systems reflect the need for shorter hydraulic retention times, higher retention of biomass, smaller reactor volume and higher loading rates, indicative of their urban locations. The companies benefit by using the biogas produced, reducing odor and the volume of sludge produced, as well as sanitizing the wastes.

However, the treatment of solid waste using AD adds several new challenges because of the variety in the feedstock and the space limitations where such facilities would be located. The organic fraction of Municipal Solid Waste (OFMSW) may contain agricultural, food, yard waste, or paper in varying concentrations, sizes, and composition. Furthermore, MSW is contaminated with non-organics, such as glass and metal, and therefore requires pre-treatment to separate the feedstock. [4].

Over 50 plants process MSW either alone or with sewage in Germany, Denmark, France, Spain, Austria, Holland, England, Belgium, and other European nations. Several types of digesters process between 50,000 and 80,000 tons of organic wastes (e.g., source separated biowastes, mixed grey wastes) per year, with the largest treating 100,000 tons, annually. [5].

Some plants accept mixed MSW, for example the Vagron plant, which treats 232,000 tons of mixed waste per year, 92,000 tons of which are organics . While Anaerobic Digestion of OFMSW is relatively well established in other nations, especially in Europe, it remains an undeveloped or developing technique in the United States [5].

Future development of AD as a MSW management strategy depends on several parameters ranging from environmental concerns to economic

considerations: increasing process efficiency, reducing digester operation costs, higher and more stable gas production.

It seems that AD systems will continue to play a major role to decompose MSW organics in other nations while the application of AD on MSW is still to be determined in Palestine.

### **1.3 Research Questions.**

The following are key research questions:

1. What are the viable options for producing renewable energy from the organic waste materials?
2. How much gas can be produced per unit weight of organic waste?
3. What is the effective cost analysis for the digestion options?

### **1.4 Research Objectives and Outputs.**

This process is still underutilizing, However, because the system is not well known to the agricultural, industrial and engineering communities.

The objectives of this thesis are to:

1. Demonstrate the effectiveness of the anaerobic digester as a cost-effective means of waste minimization and energy production.
2. Describe and explain design criteria for optimal performance.
3. Explain the benefits of anaerobic digestion of biomass for farmers, industry, and the general public.

This project, therefore is addressing multiple goals, including: improved rural-based biomass processing techniques, development of abundant, commercially relevant, and sustainable energy sources.

### 1.5 Literature Review.

Anaerobic Digestion (AD) dates back as far as the 10th century, when the Assyrians used it to heat bath water. It was historically insignificant before reappearing in 17th century Europe, when it was determined that decaying organic matter produced flammable gasses. The first full scale application was in the 1890s when the city of Exeter, UK used the first unheated and unmixed tanks with significant operational problems due to solid settling and scum formation. [6].

The first commercial applications were on farms where manure was digested to produce heat and later electricity. As the knowledge base expanded, AD was employed to treat other farm wastes, wastewater, industrial organics, and finally Municipal Solid Waste (MSW).

The energy crises in the 1970s prompted American research into alternative energy strategies, and AD was one such option. This push resulted in the first farm digester built in America in 1970 where the biogas could be used for heat and power [6].

Ducellier and Isman started to build first solid waste batch digesters in northern Africa before World War II. Their experience led to the first "Swiss" solid waste digesters, which were built in Rwanda 1982. The plant consisted of three unheated, rectangular batch-reactors of 20 m<sup>3</sup> each covered by a plastic membrane with gas storage in an extra balloon. This installation supplied the energy to cook the meals of a large agricultural school for over ten years until the time of the civil war in Rwanda. [7]

The future of anaerobic digestion of solid wastes is increasingly seen in the integration of this unique unit process in overall sustainable waste treatment.

In the anaerobic digestion of the organic fraction of municipal solid waste (OFMSW), under imperfect mixing conditions Methanogenic bacteria require sites where they should be protected from rapid acidogenesis. Volatile Fatty Acids (VFAs), which are transferred from the acidogenic to the methanogenic areas, serve as the precursor for Methane production. [8]

However, the cost of these systems is relatively high. In “wet” complete mixed systems, the organic solid waste is diluted with water to less than 15% total solid (TS), while in “dry” systems, the waste mass within the reactor is kept at a solids content in the range of 20–40% TS.[9]

Because batch digesters are technically simple, the capital cost is significantly lower than for continuously fed digesters, though some technical problems still exist. [9]

A landfill bioreactor approach has been developed to optimize landfills as biological treatment systems.

One of the most critical parameters affecting OFMSW biodegradation is the moisture content, which can be controlled via leachate recirculation. The idea of enhancing refuse decomposition by the addition of supplemental water and/or recirculation leachate was first proposed over twenty-five years ago [9].

## **Chapter Two**

**A- Renewable Energy Sources and the Environment**

**B- Potential of a Renewable Energy in Palestine**



## **A. Renewable Energy Sources and the Environment.**

### **2.1 What Is Energy?**

Energy makes change; it does things for us. It moves cars along the road. It plays our favorite songs on the radio and lights our homes. Energy makes our bodies grow and allows our minds to think. Scientists define energy as the ability to do work. People have learned how to change energy from one form to another so that we can do work more easily and live more comfortably.

### **2.2 Renewable Energy Sources and the Environment.**

Renewable energy sources include biomass, geothermal energy, hydropower, solar energy, and wind energy. They are called renewable energy sources because they are replenished in a short time. We use renewable energy sources mainly to make electricity.

The use of renewable energy is not new. Five generations (125 years) ago, wood, which is one form of biomass, supplied up to 90 percent of our energy needs. The next largest use is the production of heat and steam for industrial purposes. Renewable fuels, such as ethanol, are also used for transportation and to provide heat for homes and businesses.

Renewable energy plays an important role in the supply of energy. When renewable energy sources are used, the demand for fossil fuels is reduced.

In the past, renewable energy has generally been more expensive to use than fossil fuels. Plus, renewable resources are often located in remote areas and it is expensive to build power lines where they are needed. The use of renewable sources is also limited by the fact that they are not always

available (for example, cloudy days reduce solar energy, calm days mean no wind blows to drive wind turbines, droughts reduce water availability to produce hydroelectricity)[ 10 ].

The production and use of renewable fuels has grown more quickly in recent years due to higher prices for oil and natural gas.

### **2.2.1 Hydropower Generates Electricity.**

One of the renewable energy sources that generate electricity, hydropower is the most often used in the world.

It is one of the oldest sources of energy and was used thousands of years ago to turn a paddle wheel. Hydroelectric power plants must be located on a water source. Therefore, it wasn't until the technology to transmit electricity over long distances was developed that hydropower became widely used.

### **2.2.2 Hydropower and the Environment.**

Some people regard hydropower as the ideal fuel for electricity generation because, unlike the nonrenewable fuels used to generate electricity, it is almost free, there are no waste products, and hydropower does not pollute the water or the air.

### **2.2.3 Energy from Wind.**

Wind is, air in motion. It is caused by the uneven heating of the earth's surface by the sun. Since the earth's surface is made of very different types of land and water, it absorbs the sun's heat at different rates.

During the day, the air above the land heats up more quickly than the air over water. The warm air over the land expands and rises, and the heavier, cooler air rushes in to take its place, creating winds. At night, the winds are reversed because the air cools more rapidly over land than over water.

In the same way, the large atmospheric winds that circle the earth are created because the land near the earth's equator is heated more by the sun than the land near the North and South Poles.

Today, wind energy is mainly used to generate electricity. Wind is called a renewable energy source because the wind will blow as long as the sun shines.

#### **2.2.4 Wind and the Environment.**

In the 1970s, oil shortages pushed the development of alternative energy sources. In the 1990s, the push came from a renewed concern for the environment in response to scientific studies indicating potential changes to the global climate if the use of fossil fuels continues to increase. Wind is a clean fuel; wind farms produce no air or water pollution because no fuel is burned. Growing concern about emissions from fossil fuel generation, and higher costs for fossil fuels (especially natural gas and coal) have pushed wind power capacity grow substantially over the last 10 years.

The most serious environmental drawbacks to wind machines may be their negative effects on wild bird, populations, and the visual impact on the landscape.

### 2.2.5 Energy from the Sun.

The sun has produced energy for billions of years. Solar energy is the sun's rays (solar radiation) that reach the earth.

Solar energy can be converted into other forms of energy, such as heat and electricity. Today, people use the sun's energy for lots of things.

Solar energy can be converted to thermal (or heat) energy and used to:

- Heat Water: for use in homes, buildings, or swimming pools.
- Heat Spaces: inside greenhouses, homes, and other buildings.

Solar energy can be converted to electricity in two ways:

- Photovoltaic (PV Devices) or "Solar Cells": Change sunlight directly into electricity. PV systems are often used in remote locations that are not connected to the electric grid. They are also used to power watches, calculators, and lighted road signs.
- Solar Power Plants: indirectly generate electricity when the heat from solar thermal collectors is used to heat a fluid which produces steam that is used to power generator.

### 2.2.6 Photovoltaic Energy.

Photovoltaic energy is the conversion of sunlight into electricity. A photovoltaic cell, commonly called a solar cell or PV, is the technology used to convert solar energy directly into electrical power. A photovoltaic cell is a no mechanical device usually made from silicon alloys.

The performance of a photovoltaic array is dependent upon sunlight. Climate conditions (e.g., clouds, fog) have a significant effect on the

amount of solar energy received by a photovoltaic array and, in turn, its performance. The simplest photovoltaic systems power many of the small calculators and wrist watches used everyday. More complicated systems provide electricity to pump water, power communications equipment, and even provide electricity to our homes. Photovoltaic cells, like batteries, generate direct current (DC) which is generally used for small loads (electronic equipment). When DC power from photovoltaic cells is used for commercial applications or sold to electric utilities using the electric grid, it must be converted to alternating current (AC) using inverters, solid state devices that convert DC power to AC.

### **2.2.7 Solar Energy and the Environment.**

Solar energy is free, and its supplies are unlimited. Using solar energy produces no air or water pollution but does have some indirect impacts on the environment. For example, manufacturing the photovoltaic cells used to convert sunlight into electricity consumes silicon and produces some waste products. In addition, large solar thermal farms can also harm desert ecosystems if not properly managed.

### **2.2.8 Biomass.**

Biomass is organic material made from plants and animals. Biomass is a renewable energy source because we can always grow more trees and crops, and waste will always exist. Some examples of biomass fuels are wood, crops, manure, and some garbage. When burned, the chemical energy in biomass is released as heat. Wood waste or garbage can be burned to produce steam for making electricity, or to provide heat to homes.

### Types of Biomass

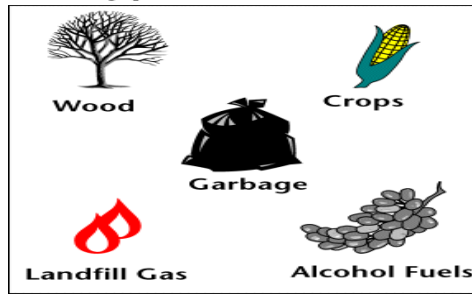

Figure (2.1): Types of Biomass. [11]

Biomass can be converted to other usable forms of energy like methane gas or transportation fuels like ethanol and biodiesel. Methane gas is the main ingredient of natural gas. Smelly stuff, like rotting garbage, and agricultural and human waste, release Methane gas - also called "Landfill gas" or "Biogas." Crops like corn and sugar can be fermented to produce the transportation fuel, ethanol. Biodiesel, another transportation fuel, can be produced from left-over food products like vegetable oils and animal fat. [11].

#### 2.2.9 Biomass and the Environment

Biomass can pollute the air when it is burned, though not as much as fossil fuels. Burning biomass fuels does not produce pollutants like sulfur that can cause acid rain. When burned, biomass does release carbon dioxide, a greenhouse gas. But when biomass crops are grown, a nearly equivalent amount of carbon dioxide is captured through photosynthesis.

## **B. Potential of Renewable Energy in Palestine.**

### **2.3 Potential of Renewable Energy in Palestine.**

#### **Climate in Palestine.**

Palestine is located between 34° 20' - 35° 30'E and 31° 10' - 32° 30'N. Palestine adjacent to the Mediterranean Sea and the West Bank extends from the Jordan River in the east to center Palestine. Palestine elevation ranges from 350m below sea level in the Jordan Valley, to sea level along the Gaza Strip seashore, exceeding 1000 m above sea level in some locations in the West Bank. [14].

Climate conditions in Palestine vary widely. The coastal climate in Gaza Strip is humid and hot during summer and mild during winter. These areas have low heating loads, while cooling is required during summer. The daily average temperature and relative humidity vary in the ranges: 13.3 - 25.4 C° and 67 - 75% respectively. In the hilly areas of the West Bank, cold winter conditions and mild summer weather are prevalent. Daily average temperature and relative humidity vary in the ranges: 8 - 23 C° and 51 - 83% respectively. In some areas the temperature decline below 0C°.

#### **2.3.1 Potential of Solar Energy in Palestine.**

Palestine has high solar energy potential, it has about 3000 sunshine hours per year and high annual average of solar radiation amounting to 5.4 kWh/m<sup>2</sup> – day on horizontal surface, which is classified as a high solar energy potential. The lowest solar energy average is in December, it amounts to 2.63 kWh/ m<sup>2</sup> - day. The solar radiation on horizontal surface varies from 2.63 kWh/m<sup>2</sup>-day in December to 8.4 kWh/m<sup>2</sup> - day in June. The peak rate of incident solar energy in Palestine occurs around 12:00 noon and is about 1,030 Watts per square meter. Table 2.1 and figure 2.3

shows the average total solar radiation per day for each month during 2000 at Jenin city as an example of West Bank region.

**Table (2.1):** The daily average of total solar radiation and wind speed for each month during 2000 at Jenin. [12]

<b>Jenin-2000</b>		
<b>Months</b>	<b>Solar Energy (Kwh/m<sup>2</sup> - day)</b>	<b>Wind Speed (m/s)</b>
1	<b>2.82</b>	<b>4.74</b>
2	<b>3.58</b>	<b>3.66</b>
3	<b>4.82</b>	<b>4.16</b>
4	<b>6.36</b>	<b>3.83</b>
5	<b>7.67</b>	<b>4.42</b>
6	<b>8.19</b>	<b>5.26</b>
7	<b>7.75</b>	<b>5.48</b>
8	<b>6.7</b>	<b>4.94</b>
9	<b>5.83</b>	<b>4.57</b>
10	<b>3.99</b>	<b>3.82</b>
11	<b>3.99</b>	<b>2.86</b>
12	<b>2.724</b>	<b>3.76</b>

The Energy Research Centre at An-Najah National University (ERC) is carrying out, since Feb 2000; measurements on solar radiation intensity using modern meteorological stations equipped with automatic data loggers as shown in Figure 2.2.



**Figure (2.2):** Meteorological station used by the Energy Research Centre at An-Najah National University [12].



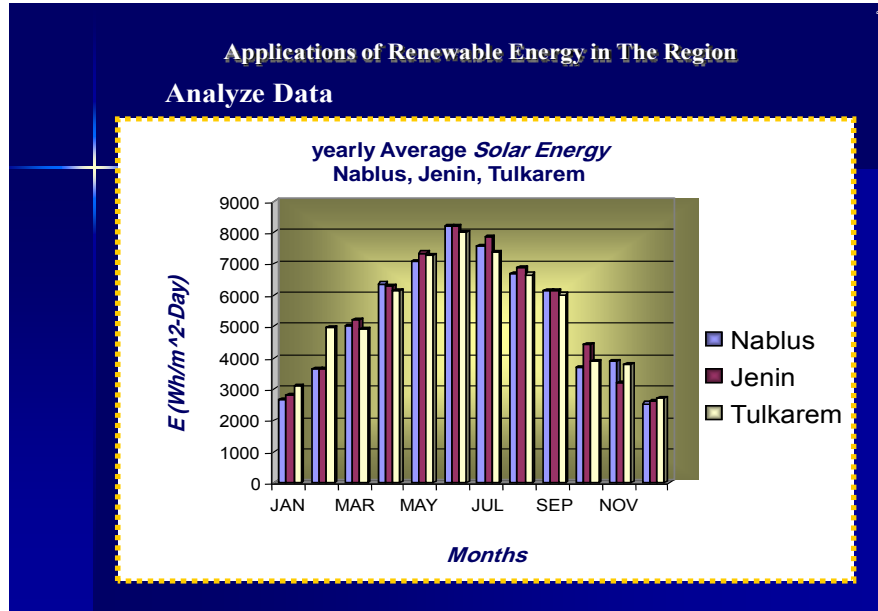

**Figure (2.3):** Yearly averages solar radiation in different cities in Palestine

The solar energy in Palestine has been utilized for crop and vegetable drying; also the solar water heaters are extensively used in the households in Palestine, about 70% of households using such systems. [12].

### 2.3.2 Potential of wind Energy in Palestine.

The annual average of wind velocity at different places in Palestine is about 3 m/s which makes the utilization of wind energy converters surely unfeasible in such places. In other places it exceeds this number and reaches up to 5.5 m/s (Al-Mazra'a Al-sharqiyah/Ramallah-Ramallah) which makes it considerable for some applications. At Nablus, the annual average of wind velocity reaches to about 4.5 m/s. [10].

Results of data analysis for the wind measurements in the two sites (Ramallah & Nablus) illustrate that the energy density available in wind for Ramallah site is about 2008 kWh/m<sup>2</sup>.year, while it is 927 kWh/m<sup>2</sup>.year, for Nablus site. [13].

A certain Palestinian case was studied (Ramallah site) to supply a certain daily load curve with a maximum power equals to 24 kW by utilizing a hybrid wind-PV system mainly dependent on wind. The cost of energy for this case was found to be 1.28 NIS/kWh. For Nablus site and to supply the same daily load curve, the cost of energy was found to be 1.4 NIS/kWh [13].

### 2.3.3 Potential of Biomass Energy in Palestine

For thousands of years people have burned wood for heating and cooking. Wood was the main source of energy in Palestine.

Agricultural in Palestine with all type of vegetable and other difrant type of wood and human waste, release methane gas - also called "landfill gas" or "biogas." can be produced from left-over food products like vegetable oils and animal fats.

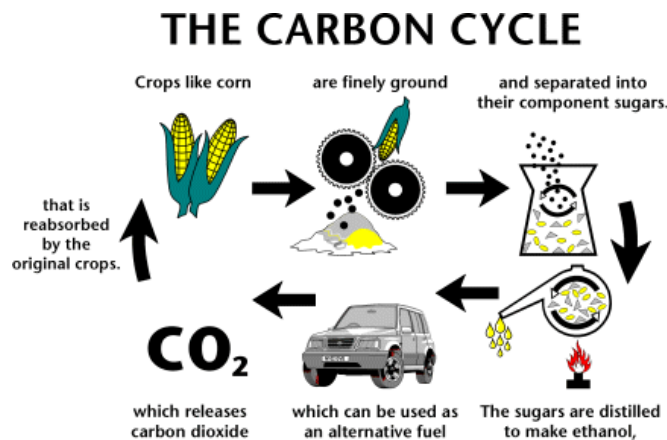

Figure (2.5): The carbon cycle. [11].

### 2.3.4 Municipal Solid Waste in Palestine

Another source of biomass is our garbage, also called municipal solid waste (MSW). Trash that comes from plant or animal products is biomass. Food scraps, lawn clippings, and leaves are all examples of

biomass trash. MSW can be a source of energy in west bank either burning MSW or by capturing biogas.

Some landfills in west bank have not a system that collects the Methane gas to be use as a fuel source. Some dairy farmers can collect biogas from tanks called "digesters" to produced Methane and this is the main objective of our thesis.

#### **2.3.4.1 Solid Waste Produced Quantities.**

Results show that the monthly produced solid waste quantities from the establishments in the Palestinian Territory in 2004 were 84.7 thousand ton, and 5,817 m<sup>3</sup>. Most of this quantity was produced from industrial activities which amount of 61.3 thousand ton, and 3,963 m<sup>3</sup>. [14]

#### **2.3.4.2 Solid Waste Separation.**

More than 92% of the establishments do not separate solid waste. The percent of establishments that separate solid waste in the Palestinian Territory in 2004 was 8% of establishments.

Results show that the paper and cartons waste ranked as the first among the separated solid waste components, followed by the medical waste and glass and metal .[14]

#### **2.3.4.3 Solid Waste Collection.**

The percent of the establishments in the Palestinian Territory in 2004 that use plastic bags to put the collected separated solid waste in was 49.6%, comparing with 18.0% of the establishments use plastic boxes. [14]

#### **2.3.4.4 Solid Waste Treatment.**

More than 98% of the establishments do not treat solid waste. The results show that the percent of establishments that treat solid waste in the Palestinian Territory in 2004 was 1.4% in the West Bank and 0.5% in Gaza Strip.

Data show that 67.9% of the establishments in the Palestinian Territory in 2004 use the open burning method in treating the solid waste, where 9.9% of the establishments use the mechanical treatment.[14]

#### **2.3.4.5 Solid Waste Disposal**

Data show that 55.5% of the establishments in the Palestinian Territory in 2004 use municipality open container for solid waste collection comparing with 29.8% of the establishments do not use containers. The percent of the establishments that use municipality open container for solid waste collection was 55.8% of the total establishments in the West Bank (56.5% of the total establishments in the Middle of West Bank, and 66.7% of the total establishments in the South of West Bank) comparing with 54.8% of the total establishments in Gaza Strip[14].

#### **2.3.4.6 Metal Containers Is the Common Type in Solid Waste Collection.**

Data show that 91.2% of the establishments in the Palestinian Territory in 2004 use metal containers for solid waste collection, of which 91.1% of the total establishments in the West Bank and 91.7% of the total establishments in Gaza Strip[14].

### **2.3.4.7 More Than 75% of the Establishments Served By Local Authority Solid Waste Disposal Services**

The percent of the establishments in the Palestinian Territory in 2004 that dispose its solid waste by itself was 14.5%, of which 22.4% in the industrial activities establishments, whereas the percent of the establishments which is served by local authority disposal services was 76.1% of which 83.1% in the education activities. Also, data reveal that, 15.4% of the total establishments in the West Bank dispose its solid waste by itself (11.0% of the total establishments in the Middle of West Bank, and 13.1% of the total establishments in the South of West Bank) comparing with 12.1% of the total establishments in Gaza Strip.

Common solid waste disposal places are the local authority dumping sites. Data show that 81.7% of the establishments in the Palestinian Territory in 2004 dispose its solid waste in a local authority dumping sites, of which 89.9% of the education establishments [14].

**Chapter Three**  
**Municipal Solid Waste,**  
**Landfill Gas,**  
**Biogas, Biofuels**

### **3.1 Municipal Solid Waste.**

MSW can be a source of energy by either burning MSW, or by capturing biogas. In waste-to-energy plants, trash is burned to produce steam that can be used either to heat buildings or to generate electricity. Trash that comes from plant or animal products is biomass. [15]

### **3.2 Burning Municipal Solid Waste (MSW).**

Plants that burn waste to make electricity must use technology to prevent harmful gases and particles from coming out of their smoke stacks. The particles that are filtered out are added to the ash that is removed from the bottom of the furnace. Because the ash may contain harmful chemicals and metals, it must be disposed of carefully. Sometimes the ash can be used for road work or building purposes.[15]

### **3.3 Facts about Landfill Gas.**

Landfill gas is about 40-60% Methane, with the remainder being mostly Carbon dioxide (CO<sub>2</sub>). Landfill gas also contains varying amounts of Nitrogen, Oxygen, water vapor, Sulfur and a hundreds of other contaminants most of which are known as "Non-Methane Organic Compounds" or NMOCs. Inorganic contaminants like mercury are also known to be present in Landfill gas. [15]

Methane is a Hydrocarbon gas (CH<sub>4</sub>). It is a greenhouse gas and it is explosive. It is generated by decomposition (in Landfills, from swamps, in the stomachs of cows, etc.).

Natural gas is approximately 80-99% Methane, with the remainder being mostly other hydrocarbons (Ethane, Propane, Butane, etc.) as well as some Nitrogen, Oxygen, Water, CO<sub>2</sub>, Sulfur and various contaminants.

About 1.5 cubic metres of Biogas equals one litre of Diesel, as shown in the figure (3.1).

### Energy Comparison: Kitchenwaste / Petrol

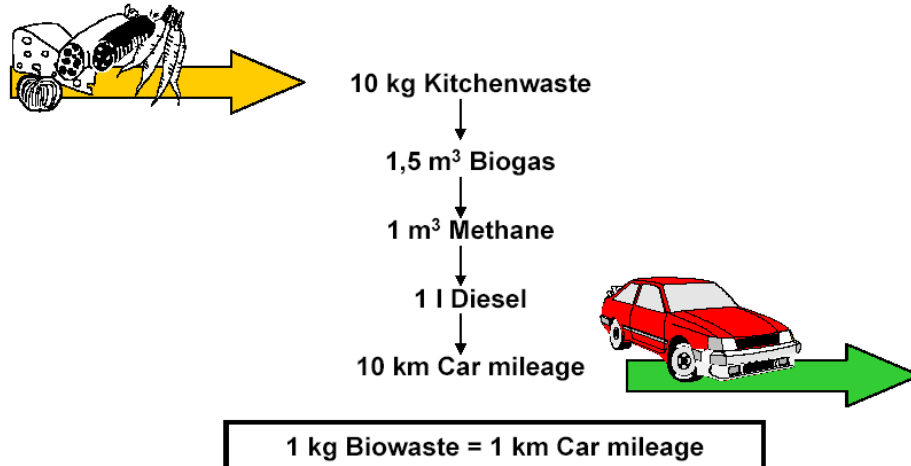

Figure (3.1): biogas energy if use as car fuel [15].

### 3.4 Collecting Landfill Gas or Biogas.

Collecting and using landfill and biogas reduces the amount of methane that is released into the air. Methane is one of the greenhouse gases associated with global climate change. Many landfills find it cheaper to just burn-off the gas that they collect because the gas needs to be processed before it can be put into natural gas pipelines.

Today's landfills are very different from the open dumps of the past. For one thing, new landfills are situated where clay deposits and other land features act as natural buffers between the landfills and the surrounding environment. [15]

Second, the bottom and sides of modern landfills are lined with layers of clay or plastic to keep the liquid waste, called leachate, from escaping into the soil.



A network of drains collects the leachate and pumps it to the surface where it can be treated. Ground wells are also drilled into and around the landfill to monitor groundwater quality and to detect any contamination.

These safety measures keep ground water, which is the main source of drinking water in many communities, clean and pure.

To protect the environment even more, the landfill is divided into series of individual cells. Only a few cells of the site (called the working face) are filled with trash at any one time, minimizing exposure to wind and rain.

At the end of each day's activities, workers spread a layer of earth called the daily cover over the waste to reduce odor.[15]

### **3.5 Biodegradation.**

Biodegradation is a natural process. It happens when micro-organisms, such as bacteria, secrete enzymes that chemically break down or degrade dead plants and animals. In other words, biodegradation is when waste decays or rots.

Most organic wastes are biodegradable under normal environmental conditions. Given enough time, the waste will disintegrate into harmless substances, enriching the soil with nutrients.

A landfill is not a normal environmental condition, though, nor is it intended to be. Instead, a landfill is more like a tightly sealed storage container. A landfill is designed to inhibit degradation to protect the environment from harmful contamination. [15]

### **3.6 Bioreactors Landfills.**

A new approach to landfills are designing them so that organic waste can allow to biodegrade. These landfills, called bioreactors, are different than most landfills used today.

One type of bioreactor is aerobic (with air). Leachate is removed from the bottom layer of the landfill and put into storage tanks. The leachate is then pumped back into the landfill, allowing it to flow over the waste repeatedly. Air is then added to the landfill. This type of bioreactor models normal air and moisture environmental conditions better than other landfills and encourages the natural process of biodegrading.

Another type of bioreactor is anaerobic (without air). In this type of landfill, air is not added, but the leachate is collected and pumped back into the landfill. Additional liquids may also be added to the leachate to help the waste biodegrade. Because the waste is broken down without oxygen, anaerobic bioreactors produce landfill gas, or methane, which can be used as an energy source.

Bioreactor landfills have advantages over traditional landfills. They reduce the cost of removing and disposing of leachate, which is used on site. Anaerobic bioreactors begin producing methane much more quickly than landfills designed to inhibit degradation. Bioreactors also gain space as the waste degrades, meaning more waste can be added.[15]

### **3.7 Landfill Energy.**

Organic waste produces a type of gas called Methane as it decomposes, or rots. Methane is the same energy-rich gas that is in natural gas, the fuel sold by natural gas utility companies. Methane gas is colorless

and odorless. Natural gas utilities add an odorant so people can detect seeping gas, but it can be dangerous to people or the environment. New rules require landfills to collect Methane gas as a pollution and safety measure.

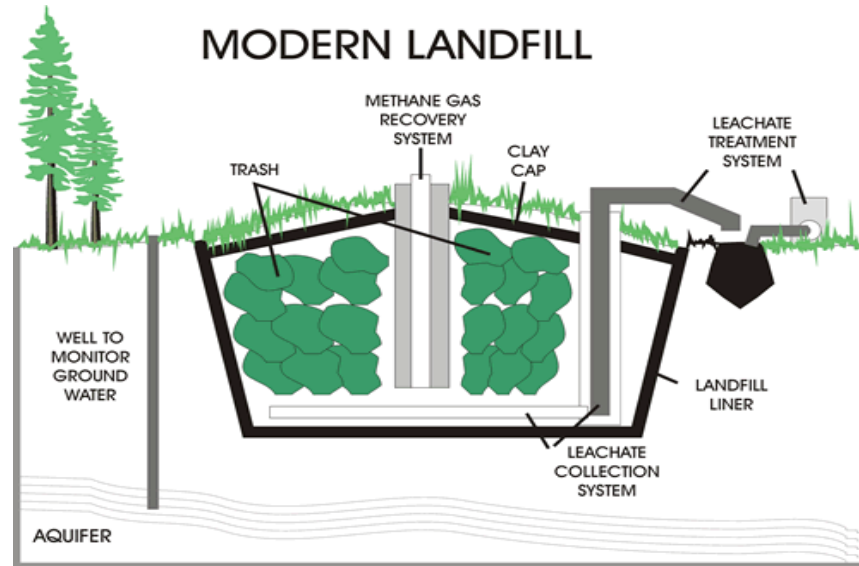
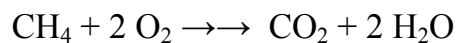

Figure (3.2): Modern landfill.[11]

### 3.8 Anaerobic Treatment.

Anaerobic treatment typically removes chemical oxygen demand (COD) by reducing the organics to methane. Therefore, the COD of the Methane produced in an anaerobic system is often equivalent to the amount of COD removed (a minor portion of the COD is utilized for biomass synthesis). The COD equivalence of Methane can be determined by stoichiometry:



For every mole of Methane consumed, two moles (64 g) of Oxygen are destroyed.

Therefore at 35C° (and 1 atm), 0.395 L of Methane is produced per gram of Chemical Oxygen Demand (COD) removed (0.39 m<sup>3</sup> CH<sub>4</sub> / kg COD removed ). This stoichiometry allows mass balances to be performed on many anaerobic treatment systems.[16]

### 3.9 Bio fuels

"Bio fuels" are transportation fuels like Ethanol and Bio Diesel that are made from Biomass materials. These fuels are usually blended with the petroleum fuels - gasoline and diesel fuel. Using Eethanol or Bio Diesel means we don't burn quite as much fossil fuel.

**3.9.1 Ethanol** is an alcohol fuel made from the sugars found in grains, such as corn, sorghum, and wheat, as well as potato skins, rice, sugar cane, sugar beets, and yard clippings. Scientists are working on cheaper ways to make ethanol by using all parts of plants and trees.

**3.9.2 Bio Diesel** is a fuel made of vegetable oils, fats, or greases - such as recycled restaurant grease. Bio diesel fuels can be used in diesel engines without changing them.

Bio diesel, a renewable fuel, is safe, biodegradable, and reduces the emissions of most air pollutants.

### 3.10 Biogas.

Biogas is generated when bacteria degrade biological material in the absence of Oxygen, in a process known as anaerobic digestion. Since biogas is a mixture of Methane (also known as marsh gas or natural gas, CH<sub>4</sub>) and Carbon Dioxide it is a renewable fuel produced from waste treatment.[15]

Anaerobic digestion is basically a simple process carried out in a number of steps that can use almost any organic material as a substrate it occurs in digestive systems, marshes, rubbish dumps, septic tanks. Humans tend to make the process as complicated as possible by trying to improve on nature in complex machines but a simple approach is still possible. [15]

$\text{CH}_4$  gas is very hard to compress, its best use as for stationary fuel, rather than mobile fuel. It takes a lot of energy to compress the gas (this energy is usually just wasted), plus the hazard of high pressure.

Variable volume storage (flexible bag or floating drum) is much easier and cheaper to arrange than high pressure cylinders, regulators and compressors. Biogas is best used directly for cooking/heating, lighting or even absorption refrigeration rather than the complication and energy waste of trying to make electricity from biogas. It is also used to run pumps and equipment of a gas powered engine rather than using electricity.

### 3.10.1 Biogas Characteristics

Bio-gas usually contains about 50 to 70 %  $\text{CH}_4$ , 30 to 40 %  $\text{CO}_2$ , and other types of gas, including Ammonia, Hydrogen Sulfide and other Noxious gas. It is also saturated with water vapor. [17].

The main constituent of biogas is the  $\text{CH}_4$  and  $\text{CO}_2$  gas. The biogas burns very well when the  $\text{CH}_4$  content is more than 50 %, and therefore biogas can be used as a substitute for kerosene, charcoal, and firewood for cooking and lighting. As shown in table 3.1[17].

**Table (3.1):** Biogas composite

<b>Table 3.1 General Composition of Bio-Gas Produced From Farm Wastes</b>		
CH <sub>4</sub>	methane	54 - 70%
CO <sub>2</sub>	carbon dioxide	27 - 45%
N <sub>2</sub>	nitrogen	0.5 - 3%
H <sub>2</sub>	hydrogen	1 - 10%
CO	carbon monoxide	0.1%
O <sub>2</sub>	oxygen	0.1%
H <sub>2</sub> S	hydrogen sulfide	trace

The relative percentage of gases in biogas depends on the feed material and management of the process.

1- **Table (3.2)** Characteristics for CH<sub>4</sub> [18]

**Table (3.2):** Characteristics for CH<sub>4</sub>

Common synonyms	Marsh gas, fire damp
Formula	CH <sub>4</sub>
Physical properties	Form: colorless, odorless gas Stability: Stable T <sub>m</sub> : -182 <sup>0</sup> C T <sub>b</sub> : -164 <sup>0</sup> C T <sub>f</sub> : -1221 <sup>0</sup> C T <sub>a</sub> : 537 <sup>0</sup> C S: slight (25mg/L at 20 <sup>0</sup> C) ρ = 0.717 kg/m <sup>3</sup> at 20 <sup>0</sup> C
Principal hazards	CH <sub>4</sub> is very flammable. CH <sub>4</sub> can react violently or explosively with strong oxidizing agents, such as oxygen, halogens or interhalogen compounds. At high concentration methane acts as an asphyxiant.

Safe handling	Wear safety glasses. The primary danger is from fire and explosion, so ensure work in a well-ventilated area, preferably within a fume cupboard, and that there is no source of ignition present.
Emergency	Eye contact: Unlikely to occur. Skin contact: Unlikely to occur. If inhaled: Remove from the source of gas. If the amount inhaled is large or if breathing has ceased call for immediate medical help.
Disposal	Small amounts of CH <sub>4</sub> can be allowed to disperse naturally. Be aware that any significant build-up of gas presents a danger of fire or explosion.
Protective equipment	Safety glasses.
Heating value	The heat value of biogas equal 1/2 heat value of butane gas [10] = 9.5 kWh/Kg biogas (34200 kJ /kg).

## 2- Characteristics of different fuel gases table (3.3) [19]

**Table (3.3):** Characteristics of different fuel gases.

Parameter Biogas	Unit	Natural Gas	Town Gas	60% CH <sub>4</sub> , 38%CO <sub>2</sub> , 2% Other
Calorific value (lower)	MJ/m <sup>3</sup>	36.14	16.1	24.521
Density kg/m <sup>3</sup>	kg/m <sup>3</sup>	0.82	0.51	0.717
Theory. air requirement	m <sup>3</sup> air/ m <sup>3</sup> gas	9.53	3.83	5.71
Max. ignition velocity	m/s	0.39	0.70	0.25

## **Chapter Four**

### **Biogas Generation**



## **4.1 Biogas Technology in the World.**

### **4.1.1 Anaerobic Digestion in Europe.**

In Europe the European Commission has taken some important decisions to promote renewable energy in general and biomass in particular. Further more, fossil fuel consumption for transport should also be increasingly substituted by biomass to reach 8% by 2020. Spain reportedly sends the most waste to anaerobic digestion of all the EU countries. This has been precipitated in part by a directive by the Spanish parliament in August 2005 to increase renewable energy production from 19 percent of the total energy mix to 31 percent. [20]

### **4.1.2 Anaerobic Digestion in North America.**

There are two full-scale AD facilities currently operating in North America that process MSW, both near Toronto, Ontario, Canada.

The City of Toronto's Dufferin Organics Processing Facility has been operating full scale at a capacity of 25,000 MT/year since 2004. It is located at the city's Dufferin Transfer Station. The city's Green Bin program provides curbside household organics collection to 500,000 households and 20,000 businesses; therefore a large source separated organics stream is available for processing at the facility. [21].

The second facility, located in Newmarket, Ontario outside of Toronto. The plant, owned by Halton Recycling, had been closed but recently restarted at a lower throughput than its design capacity of 400 MT/day [22].

Until very recently, there were no anaerobic digestion facilities operating in the United States that processed MSW or source separated

organic waste. In October 2006, Onsite Power Systems Inc., in association with the University of California Davis, launched their biogas energy project with the start-up of an anaerobic digester.

The analysis concluded that AD offered better environmental performance than waste to energy facilities, with lower air pollutant emissions, increased beneficial use of waste and reduced reliance on landfilling.

#### **4.1.3 The Future Looks Bright for Biogas Technology.**

As with all forms of bio energy, the future looks bright for biogas technology. As a CO<sub>2</sub>-neutral source of energy it will be increasingly used to meet the Kyoto Protocol commitments and to benefit from the CO<sub>2</sub>-emission trade.

Biogas is a flexible form of renewable energy that can produce heat, electricity and serve as a vehicle fuel. As well as energy, the AD process yields valuable fertilizer and reduces emissions and odour nuisances.

In the USA, especially in California, low emission cars are becoming an important issue.

AD has all the advantages to become increasingly one of the most efficient and economical sources of renewable fuel.

AD has also been shown to be an economically viable technology for both small scale rural applications in developing countries and for a range of scales in the developed world.

There are digesters with a single and a double membrane cover. The advantage of the rubber top digester is the price. A membrane is cheaper

than a concrete cover. At the same time, the membrane serves as gas storage whereas concrete top digesters need additional gas storage.

Often rubber top digesters give problems of odour emission when the rubber (usually black) is inflated due to heating by the sun.



**Figure (4.1): Rubber top digesters [23]**

#### **4.1.4 Biogas Technology in Arab Countries.**

In Arab countries the applying of biogas plants started in 1970s in Egypt, Morocco, Sudan and Algeria while it began in 1980s in other Asian Arab countries as Iraq, Jordan and Yemen. In Egypt there were 18 family biogas plants and 2 farm plants built till 1998, also two family biogas plants were built in Keraeda and Um-Jar villages of Sudan in the period between 19/1 and 16/2/2001. There were two constructed plants for producing biogas from liquid wastes in Jordan, one in Ain-Ghazal and the other in the central station of Irbid [24].

## 4.2 Anaerobic Digestion.

### 4.2.1 Fundamentals of Anaerobic Treatment.

Anaerobic treatment consists of the biochemical conversion of organic materials by a consortium of microorganisms, typically in the absence of oxygen, to methane and carbon dioxide.

There are two key principles which are important to the application of anaerobic treatment: series metabolism and the COD equivalence of methane. The anaerobic process microbiology consists of four steps as shown in figure (4.2). [26+25]

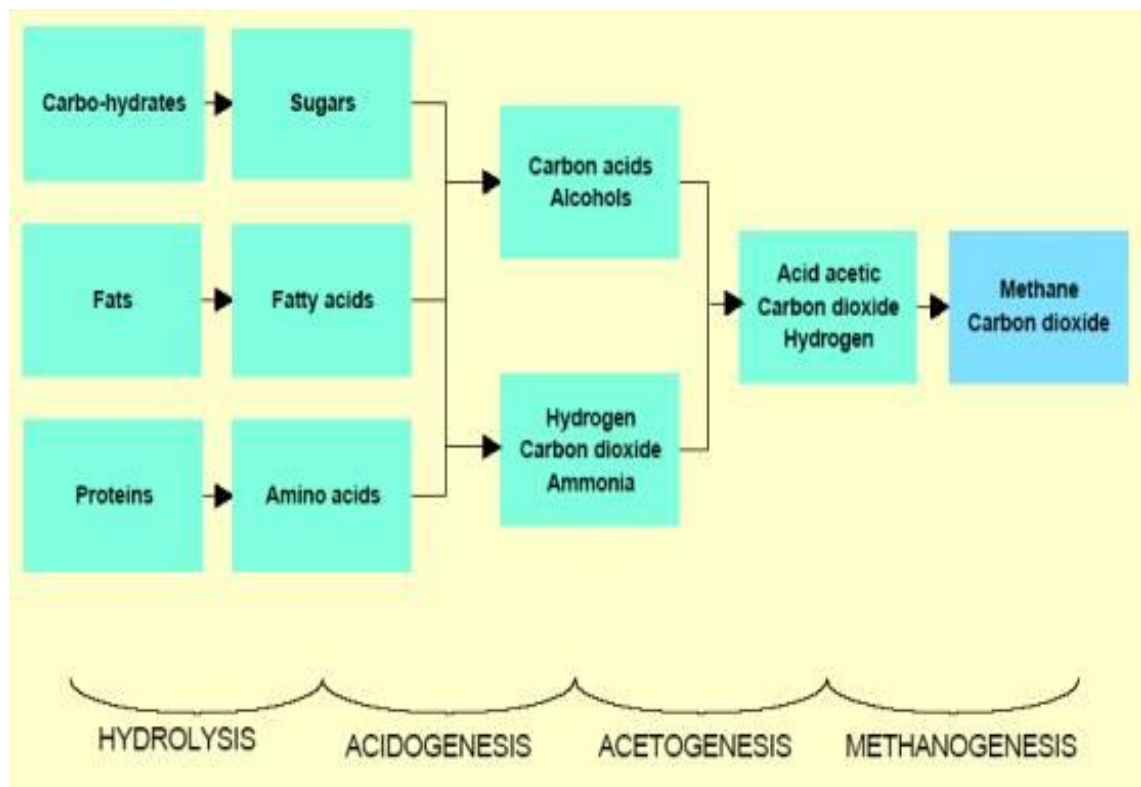

Figure (4.2): Anaerobic process microbiology consists of four steps

#### 4.2.1.1 Hydrolysis.

Hydrolysis is an enzymemediated conversion of complex organic compounds (carbohydrates, proteins, and lipids) to simple organics (sugar, amino acids, and peptides) for use as an energy source and cell carbon.

Hydrolysis and liquefaction is the breakdown of large, complex, and insoluble organics into small molecules that can be transported into microbial cells and metabolized. Essentially, organic waste stabilization does not occur during hydrolysis; the organic matter is simply converted into a soluble form that can be utilized by the bacteria.

#### 4.2.1.2 Fermentation or Acidogenesis.

**Acidogenesis** is the process in which bacterial fermentation (by the acidogens) of the hydrolysis products results in the formation of volatile acids. The hydrogen-producing acetogens convert the volatile acids (longer than two carbons) to acetate and hydrogen. These microorganisms are related and can tolerate a wide range of environmental conditions. Under standard conditions, the presence of hydrogen in solution inhibits oxidation, so that hydrogen bacteria are required to endure the conversion of all acids.

#### 4.2.1.3 Acetogenesis.

The simple molecules from acidogenesis are further digested by bacteria called acetogens to produce CO<sub>2</sub>, hydrogen and mainly acetic acid. [15]

#### 4.2.1.4 Methanogenesis.

Methanogens convert the acetate and hydrogen to methane and carbon dioxide. Or Methanogenesis - methane, CO<sub>2</sub> and water are produced by bacteria called methanogens.[15]

The primary route is the fermentation of the major product of the acid forming phase, acetic acid, to methane and carbon dioxide. Bacteria that utilize acetic acid are acetoclastic bacteria (acetate splitting bacteria). The overall reaction is:



About two-thirds of methane gas is derived from acetate conversion by acetoclastic methanogens. Some methanogens use Hydrogen to reduce Carbon dioxide to Methane (hydrogenophilic methanogens) according to the following overall reaction .

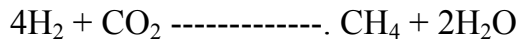

Circumstances in treating solid wastes, acetate is a common end product of acidogenesis. This is fortunate because acetate is easily converted to methane in the methanogenic phase. Due to the difficulty of isolating anaerobes and the complexity of the bioconversion processes, much still remains unsolved about anaerobic digestion.

The principle acids produced in Stage 2 are processed by methanogenic bacteria to produce CH<sub>4</sub>. The reaction that takes place in the process of CH<sub>4</sub> production is called Methanization and is expressed by the following equations

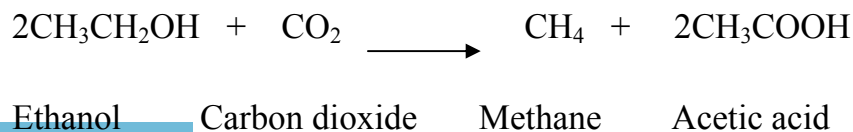
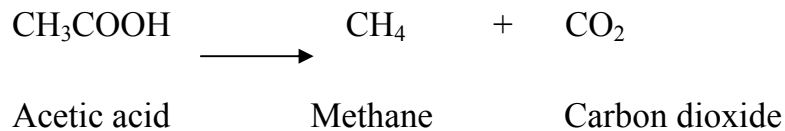

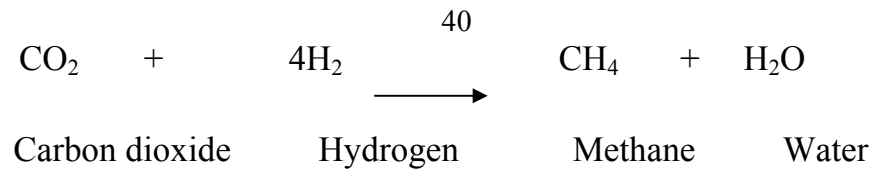

The above equations show that many products, by-products and intermediate products are produced in the process of digestion of inputs in an anaerobic condition before the final product CH<sub>4</sub> is produced. [26+25]

#### 4.3 Biological and Chemical Oxygen Demand. [27].

**4.3.1 The Biological Oxygen Demand (BOD)** is a measure of the quantity of dissolved organic pollutants that can be removed in biological oxidation by the bacteria. It is expressed in **mg/l**.

**4.3.2 The Chemical Oxygen Demand (COD)** measures the quantity of dissolved organic pollutants than can be removed in chemical oxidation, by adding strong acids. It is expressed in **mg/l**.

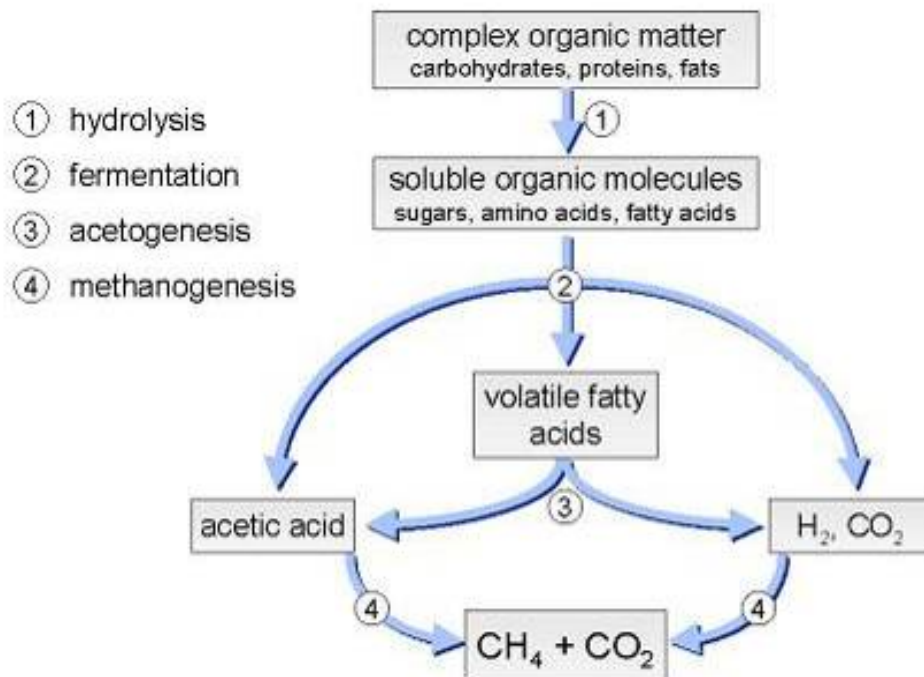

Figure (4.3): Path of Anaerobic Digestion. [27].

## 4.4 Basic Digester Design

### 4.4.1 One Stage Vs. Two Stage

Some manufacturers design their AD systems for both the first and second phases to occur in one tank. Others split the phases into two tanks in order to optimize operating conditions for each.

Single stage digestion is a simple design with a longer track record, and has lower capital costs and technical problems.

Two stage systems have lower retention times as each stage design is optimized. There is a potentially higher gas yield with two stage systems, but higher capital costs.

Biogas generation varies by material. There is limited information on the comparative biogas generation of different materials in source separated organics or mixed waste streams.

The comparative gas yield (from most to least) is: Office paper, mixed paper, cardboard and boxboard; Food; Telephone directories and newspaper; Brush; Grass; Leaves.

### 4.4.2 Wet vs Dry.

Moisture is added to the incoming waste stream, which is preprocessed by a number of different technologies. The higher moisture content of wet digestion is an advantage for programs with a lot of plastic, as the plastic can be floated off before digestion. Wet digestion typically results in a loss of volatile solids from the incoming waste stream, and this can lead to lower gas yields.



Wet digestion also uses more of the energy generated from biogas (up to 50 percent) for higher in-plant energy needs (pumping, dewatering) than dry digestion technologies (20 to 30 percent of energy is typically required for in-plant needs). [20]

#### **4.4.3 Batch Feeding (Mostly Solids).**

There is biogas systems designed to digest solid vegetable waste alone. Since plant solids will not flow through pipes, this type of digester is best used as a single batch digester. The tank is opened, old slurry is removed for use as fertiliser and the new charge is added. The tank is then resealed and ready for operation.

Dependent on the waste material and operating temperature, a batch digester will start producing biogas, slowly increase in production then drop off after one or tow months. Batch digesters are therefore best operated in groups, so that at least one is always producing useful quantities of gas.

Most vegetable matter has a much higher carbon - nitrogen ratio than dung has, so some nitrogen producers (preferably organic) must generally be added to the vegetable matter, especially when batch digestion is used. Weight for weight, however, vegetable matter produces about eight times as much biogas as manure, so the quantity required is much smaller for the same biogas production. A mixture of dung and vegetable matter is hence ideal in most ways, with a majority of vegetable matter to provide the biogas and the valuable methane contained in it.

#### **4.4.3.1 Advantages of Batch digesters.**

Batch digesters have advantages where the availability of raw materials is sporadic or limited to coarse plant wastes (which contain undigestible materials that can be conveniently removed when batch digesters are reloaded). Also, batch digesters require little daily attention.

#### **4.4.3.2 Disadvantages of Batch digesters.**

Batch digesters have disadvantages, however, in that a great deal of energy is required to empty and load them; also gas and sludge production tend to be quite sporadic. We can get around this problem by constructing multiple batch digesters connected to the same gas storage. In this way individual digesters can be refilled in staggered sequence to ensure a relatively constant supply of gas.

#### **4.4.4 Continuous-Load Digesters “First-In First-Out”.**

With continuous-load digesters, a small quantity of raw material is added to the digester every day. Continuous-load digesters are especially efficient when raw materials consist of a regular supply of easily digestible wastes from nearby sources such as livestock manures.

Continuous-feeding digesters can be of two basic designs: vertical-mixing or displacement as shown in Figure (4.4). [28]

Vertical-mixing digesters consist of vertical chambers into which raw materials are added. The slurry rises through the digester and overflows at the top.

Single-chamber designs the digested or "spent" slurry can be withdrawn directly from effluent pipes. In double-chamber designs the

spent slurry, as it overflows the top, flows into a second chamber where digestion continues to a greater degree of completion.

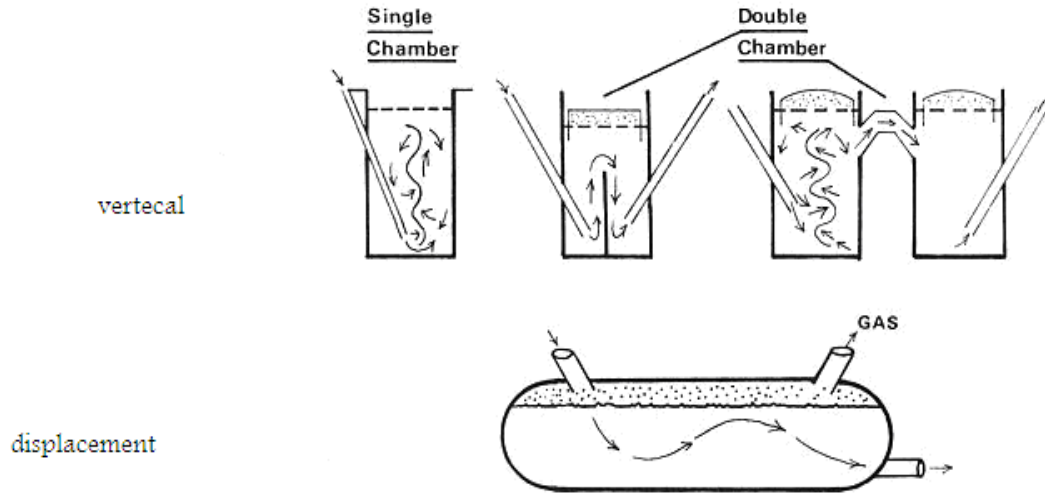

**Figure (4.4):** Continuous digester [28]

Displacement digesters consist of a long cylinder lying parallel to the ground (e.g., inner tubes, oil drums welded end on end, tank cars, etc.). As it is digested the slurry is gradually displaced toward the opposite end, passing a point of maximum fermentation on the way.

In vertical-mixing digesters raw material is subject to a vertical pumping motion and often escapes the localized action of digesting bacteria. Slurry introduced at one time can easily be withdrawn soon afterwards as incompletely digested material.

Any continuous-load digester will eventually accumulate enough scum and undigested solid particles so that it will have to be cleaned. The periodical washing out of displacement digesters is considerably easier than vertical-mixing digester. This system is unlike other organic waste digestion systems in that it is not a batch process but a continuous process allowing

continuous intake of feedstock and continuous removal of output products thereby reducing the requirement for waste and product storage.

An even more significant advantage of this system is that the processing speed can be constantly and automatically adjusted to ensure complete digestion of the waste material that passes through it, thereby ensuring that the output products are clean and free of toxic or undigested waste. This offers not only environmental benefits but sound investment potential also. Low construction and operating costs give potential for a high return on investment from the sale of the output products and from the collection of 'gate fees' for the receiving of waste materials.

Gas production can be accelerated and made more consistent by continuously feeding the digester with small amounts of waste daily.

If such a continuous feeding system is used, then it is essential to ensure that the digester is large enough to contain all the material that will be fed through in a whole digestion cycle. One solution is to use a double digester, consuming the waste in two stages, with the main part of the biogas (methane) being produced in the first stage and the second stage finishing the digestion at a slower rate.

#### **4.4.5 Stirring.**

Some method of stirring the slurry in a digester is always advantageous, if not essential. If not stirred, the slurry will tend to settle out and form a hard scum on the surface, which will prevent release of the biogas.

This problem is much greater with vegetable waste than with manure, which will tend to remain in suspension and have better contact

with the bacteria as a result. Continuous feeding causes less problems in this direction, since the new charge will break up the surface and provide a rudimentary stirring action.

#### **4.4.6 above or below Ground?**

Biogas plants constructed above ground must be made of steel to withstand the pressure within, and it is generally simpler and cheaper to build the digester below ground. This also makes gravity feed of the system much simpler. Maintenance is, however, much simpler for systems built above ground and a black coating will help provide some solar heating.

This should make it clear that biogas is not just a dream, but a practical application and use of a waste product.

#### **4.5 Available Feedstocks for AD.**

##### **4.5.1 Sewage Sludge.**

Digestion of sewage sludge provides significant benefits when recycling the sludge back to land. The digestion process sanitises and also reduces the odour potential from the sludge. However, AD is still considered an important step since it produces renewable energy and improves the ability of the sludge to settle which makes it easier to dry.

In less developed countries, direct AD is the only treatment of waste water. If the digester is adequately designed and the retention time of the water is long enough, the quality of the treated water can be excellent.

#### 4.5.2 Agricultural Wastes.

Digestion of animal manure is probably the most widespread AD application worldwide. It produces a valuable fertiliser as well as biogas. Today, more and more organic industrial waste materials are added to the manure which brings increased gas production. In countries like Denmark, Austria and Germany the easily degradable wastes are becoming scarce and farmers are looking for alternative substrates (energy crops) such as corn, barley, rye or grass. In Germany the income from electricity produced from biogas made from corn is higher than using the same crop to feed fattening beef. Germany and Austria receive higher feed-in tariffs when the biogas is produced with crops. Figure (4.5) Shows electricity output per Metric Ton (M.T)

#### Electricity output - Cofermentates

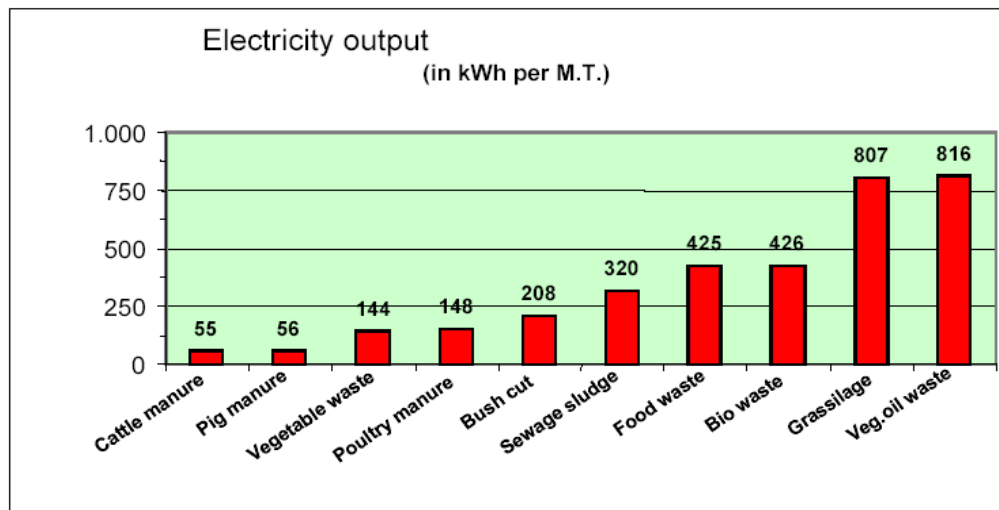

Figure (4.5): Electricity output per M.T[29]

#### 4.6.3 Industrial Wastes.

Organic solid wastes from industry are increasingly treated in biogas plants. Even if some of the substances might be difficult to digest as a sole substrate, in mixture with manure or sewage sludge they don't pose any problem.

Most of the waste products from the food industry have excellent gas potential and therefore are in demand by plant operators. Now, the operators are starting to pay for the waste materials with the highest gas potential like fat and vegetable oil. With current high feed-in tariffs they can easily recover the cost of these wastes.

AD of industrial waste waters is becoming a standard technique. Whilst AD is only an initial stage in the treatment of high quality water discharge, it can significantly reduce the cost and size of plant compared to wholly aerobic treatments.

#### **4.7 Factors Affect the Rate of Digestion and Biogas Production.**

Several parameters within the anaerobic digester affect the physical environment and therefore the efficiency of digestion and biogas production potential. AD facility operators must monitor the following parameters within acceptable ranges: pH, temperature, C/N ratio, retention time, organic loading rate, bacterial competition, nutrient content, toxicants, solids content, and mixing/agitation. The optimum ranges and importance of these critical factors are described below.

##### **4.7.1 PH.**

The ideal pH values of effluent in sewage treatment plants is 7 to 7.5, and these values are usually given as the best pH range for digesters in general. A slightly more alkaline mixture is best for digesters using raw animal or plant wastes. You can measure the pH of your digester with "litmus" or pH paper. Dip the pH paper into the effluent. Litmus paper turns red in acid solutions (pH 1 to 7) and blue in alkaline solutions (pH 7 to 14).

**Table (4.1):** Problems with pH value. [30]

<b>Table (4.1): Problems with pH.</b>		
<b>Condition</b>	<b>Possible Reasons</b>	<b>"Cure"</b>
Too acid (pH 6 or less)	1) Adding raw materials too fast	Reduce feeding rate; Ammonia
	2) Wide temperature fluctuation	Stabilize temperature
	3) Build-up of scum	Remove scum
Too Alkaline (pH 9 or more)	1) Initial raw material too alkaline	Patience never put acid into digester

If the pH in the continuous-load digester becomes too acidic, you can bring it up to normal again by adding fresh effluent to the inlet end, or by reducing the amount of raw material fed to the digester. If the effluent becomes too alkaline, a great deal of CO<sub>2</sub> will be produced, which will have the effect of making the mixture more acidic.

Patience is the best "cure" in both cases. Never add acid to your digester. This will only increase the production of hydrogen sulfide. The pH varies in response to biological conversions during the different processes of AD.

The optimum pH range for methanogenic bacteria is between 6 and 8, but the optimum pH for the group as a whole is near 7.

On the other hand, prolific methanogenesis may result in a higher concentration of ammonia, increasing the pH above 8.0, where it will impede acidogenesis.[30]

The common materials used to increase the alkalinity are lime, soda ash, ammonia, ammonium bicarbonate, sodium hydroxide, or sodium bicarbonate. Generally lime, sodium hydroxide, and ammonia are the least expensive of these chemicals. An advantage of adding alkali is that it induces swelling of particulate organics, making the cellular substances more susceptible to enzymatic attack.



## **4.7.2 Temperature.**

### **Mesophilic vs. Thermophilic**

**4.7.2.1 Meso-philic** digesters operate at a lower temperature, and therefore retention time is longer (15 to 40 days) to generate the same level of organic breakdown.

Gas production is reported to be lower in mesophilic digesters, although the biological process is considered to be more stable.

The optimum temperature for mesophilic digestion is 35°C (95°F) and a digester must be maintained between 30°C and 37°C for most favorable functioning.[30]

### **4.7.2.2 Thermophilic.**

Thermophilic digestion allows higher loading rates and achieves a higher rate of pathogen destruction as well as a higher degradation of the substrate and smaller digester size at lower capital cost. A digester must be maintained between 50°C and 57°C for most favorable functioning this is perhaps one of the most critical parameters to maintain in a desired range.

## **4.7.3 C/N ratio**

The Carbon/Nitrogen (C/N) ratio is a measure of the relative amounts of Organic Carbon and Nitrogen present in the feedstock. The C/N ratio of the collected waste is determined by its composition. If the C/N ratio of OFMSW is very high, the waste used as single substrate will be deficient in nitrogen, which is needed for build up of bacterial communities. As a result the gas production will be low.[10]

If the C/N ratio is very low, Nitrogen will be liberated and accumulate in the form of ammonia. This will increase the pH value of the material and a pH value higher than 8.5 will start to show a toxic effect on the methanogenic bacterial communities. For example, proteins such as meats are high in nitrogen while paper products contribute relatively more carbon. A C/N ratio of 20–30 is considered to be optimum for an anaerobic digester, based on biodegradable organic carbon. The C/N ratio, based on biodegradable organic carbon from food and yard waste is below 20, and for mixed paper is more than 100. Animal waste, such as cattle manure, which has been used successfully in biogas systems for many years, has an average C/N ratio of 24. The human excreta have a C/N ratio as low as 8. Plant materials contain a high percentage of carbon and so the C/N ratio is high (e.g. rice straw = 70, sawdust > 200). To maintain the C/N level of the digester material at acceptable levels, materials with high C/N ratio can be mixed with those with a low C/N ratio, i.e. organic solid waste can be mixed with municipal sewage, biosolids, or animal manure. A C/N ratio ranging from 20 to 30 is considered optimum for anaerobic digestion. If the C/N ratio is very high, the nitrogen will be consumed rapidly by methanogens for meeting their protein requirements and will no longer react on the left over carbon content of the material. On the other hand, if the C/N ratio is very low, Nitrogen will be liberated and accumulated in the form of Ammonia ( $\text{NH}_4$ ),  $\text{NH}_4$  will increase the pH value of the content in the digester [10]. C/N ratios of some of the commonly used material are presented in Table 4.2.

**Table (4.2):** C/N ratio of some organic materials [10]

Sample	Raw Materials	C/N Ratio
1.	Duck dung	8
2.	Human excreta	8
3.	Chicken dung	10
4.	Goat dung	12
5.	Pig dung	18
6.	Sheep dung	19
7.	Cow dung/ Buffalo dung	24
8.	Water hyacinth	25
9.	Elephant dung	43
10.	Straw (maize)	60
11.	Straw (rice)	70
12.	Straw (wheat)	90
13.	Saw dust	above 200

Materials with high C/N ratio could be mixed with those of low C/N ratio to bring the average ratio of the composite input to a desirable level [29].

**Table (4.3):** Effects of C/N ratio [30]

Table 4.3 Gas Production According to C/N Ratios of Raw Wastes					
		Methane	CO <sub>2</sub>	Hydrogen	Nitrogen
-	-				
C/N Low (high nitrogen)	blood, urine	little	much	little	much
C/N High (low nitrogen)	sawdust, straw, sugar and starches such as potatoes, corn, sugar beet wastes	little	much	much	little
C/N Balanced (C/N = near 30)	manures, garbage	much	some	little	little

#### 4.7.4 Mixing.

This parameter is primarily a function of the hydraulic regime (mixing) in the reactors. Mixing of the substrate in the digester helps to distribute organisms uniformly throughout the mixture and to transfer heat. The importance of adequate mixing is considered to encourage distribution of enzymes and microorganisms throughout the digester where MSW decomposition is carried out. Furthermore, agitation aids in particle size reduction as digestion progresses and in removal of gas from the mixture.

The material inside any digester may be further mixed through mechanical or gas mixers that keep the solids in suspension. Often biogas is bubbled through the digester as an inexpensive way to promote movement. Mechanical mixers inside digesters are less common because maintenance is somewhat difficult.

Mixing can also be achieved through the recirculation of waste. After digested waste is removed from the reactor at the end of its retention time, a percentage of it is fed into the stream of incoming fresh waste. This serves to contact the fresh waste with bacterial mass and increase movement in the digester, which prevents the buildup of a scum layer.

Some investigators have demonstrated that gentle or slow mixing may improve anaerobic digester performance.

#### 4.7.5 Retention Time.

The Hydraulic Retention Time (HRT) is a measure of the rate of substrate flow into and out of a reactor. The HRT is determined by the average time it takes for organic material to digest, as measured by the COD and BOD of the exiting effluent.

The HRT for most dry (influent solids content of above 20%) anaerobic processes range between 14 and 30 days and for wet (influent solids content of below 20%) anaerobic processes can be as low as 3 days. The optimal value varies according to the specific technology in place, the process temperature and the solid waste characteristics. For a specific anaerobic digester, therefore, the HRT may change from day to day or from season to season. Reducing HRT reduces the size of the digester, resulting in cost savings. Therefore, there is an incentive to design systems that can achieve a complete digestion in shorter HRT. A shorter HRT will lead to a higher production rate per reactor volume unit, but a lower overall degradation. These two effects have to be balanced in the design of the full-scale anaerobic digester.

Several practices have generally been accepted as helping to reduce HRT. Two of these are continuous mixing and utilizing low solids. One method generally accepted for minimizing HRT is mixing the digester.

The other method is to re-circulate water and biogas in the digester to keep material moving. This will ensure that bacterial populations have rapid access to as many digestible surfaces as possible and that environmental characteristics are consistent throughout the digester.

#### **4.7.6 Organic Loading Rate.**

The Organic Loading Rate (OLR) represents the amount of organics that must be handled by the anaerobic system measured in mass of organic influent to the system per unit volume per time, which is another important process control parameter in AD systems to treat solid organic wastes. This parameter is used as an index of the stress imposed on the microbial population and affects the amount of total gas, methane production, COD stabilization, and alkalinity.

A higher OLR will demand more of the bacteria, which may cause the anaerobic consortium system to crash if it is not prepared. One danger of rapid increase in the OLR would be that the acidogenic bacteria, which act early in the digestion process and reproduce quickly given enough substrate, would multiply and produce acids rapidly.

The pH of the system would then fall, killing more of the methanogenic bacteria and leading to a positive feedback loop, eventually halting digestion resulting in a digester crash or failure. Many AD facilities have reported system failures due to organic overloading. Low biogas production and a lower pH are early indicators of failure.

#### 4.7.7. Toxicity.

Heavy metals such as copper, nickel, chromium, zinc, and lead are essential for bacterial growth in small quantities, but higher quantities will have a toxic effect.

Mineral ions, heavy metals and detergents are some of the toxic materials that inhibit the normal growth of bacteria in the anaerobic digester. Low concentrations of minerals (sodium, potassium, calcium, magnesium, ammonium, and sulfur) stimulate the bacterial growth, but become inhibitory as the concentrations increase.

The following are some toxicants that are known to cause problems in AD systems. [31]

**Ammonia-nitrogen** Ammonia-nitrogen-containing solid waste, or its precursors, is of concern because of the potential inhibitory effects of ammonia on the AD microbial consortia

Finally, buildup of ammonia- nitrogen may result in undetected accumulation of Volatile Fatty Acids (VFAs) because ammonia will keep the pH above 8.

Sulfide toxicity is a common problem with organic waste containing high concentrations of sulfate. Sulfate is used primarily as an electron acceptor in organic waste treatment the inhibiting levels of some of the major ones are given in Table (4.4) [31].

**Table (4. 4): Toxic level of various inhibitors [31]**

S. N.	Inhibitors	Inhibiting Concentration
1.	Sulphate (SO <sub>4</sub> ) <sup>-2</sup>	5.000 ppm
2.	Sodium Chloride	40.00 ppm
3.	Nitrate (Calculated as N)	0.05mg/mL
4.	Copper (Cu <sup>+2</sup> )	100 mg/L
5.	Chromium (Cr <sup>+3</sup> )	200 mg/L
6.	Nickel {Ni <sup>+3</sup> }	200 - 500 mg/L
7.	Sodium (Na <sup>+</sup> )	3.500 – 5.500 mg/L
8.	Potassium (K <sup>+</sup> )	2.500 – 4.500 mg/L
9.	Calcium (Ca <sup>+2</sup> )	2.500 - 4.500 mg/L
10.	Magnesium (Mg <sup>+2</sup> )	1.00 – 1.500 mg/L
11.	Manganese (Mn <sup>+2</sup> )	Above 1.500 mg/L

#### 4.7.8 Slurry.

This is the residue of inputs that comes out from the outlet after the substrate is acted upon by the methanogenic bacteria in an anaerobic condition inside the digester. After extraction of biogas (energy), the slurry (also known as effluent) comes out of digester as by-product of the anaerobic digestion system. There is less separation in the slurry if the feed materials are homogenous. Appropriate ratio of urine, water and excrement and intensive mixing before feeding the digester leads to homogeneous slurry [32].

## 4.8 Biogas Plants Types.

The biodigester is a physical structure, commonly known as the biogas plant. Since various chemical and microbiological reactions take place in the biodigester, it is also known as bio-reactor or anaerobic reactor.

The main function of this structure is to provide anaerobic condition within it. As a chamber, it should be air and water tight. It can be made of various construction materials and in different shape and size.

## 4.9 Size types.

### 4.9.1 The Family – Size Units.

For normal family eight person family needs one butane bottle for cooking and heating which is about 12 kg of  $C_4H_{10}$  / month and the heating value for Bio gas is half of butane gas then we need 24 kg of bio gas /month. These units seem to be the most promising sizes. For these units organic wastes of three or more equivalent animal units plus the human waste and kitchen waste of an eight person family can be fed. This waste is enough to produce biogas to supply the household with its cooking gas needs. [10]



**Picture (1):** Nablus Industrial School Digester as Family Size Units.



#### **4.9.2 The Community – Type Units**

These units are to be shared by neighbors, usually relatives. These units will be fed by combined feed stock of human and animal wastes. Also, these units can be used in public latrines in schools, factories, hospitals. It is expected that these units will face problems in their operation and maintenance as a result of the social structure.

#### **4.9.3 The Large- Scale Systems**

There is a large quantity of organic waste; these are suitable for large mechanized biogas plants. This includes installation of modified biogas fueled internal combustion engine driving electric generator for lighting and operating small household electrical appliances in the village. The situation in many villages is such that the villages do not have electricity or even running water. In these cases the community indicated that their urgent need is supplying them with electricity from biogas.

#### **4.10 Design types.**

##### **4.10.1 Floating Drum Digester.**

A floating drum biogas plant popularly known as Gobar Gas Plant was developed in 1956 by Jashu Bhai J. In 1962, Patel's design was approved by KVIC of India and this design soon became popular in India and the world.[34]

##### **4.10.2 Fixed Dome Digester (Drumless Digester).**

This type of digester was built in China as early as 1936. It consists of an underground brick masonry compartment (fermentation chamber) with a dome on the top for gas storage. In this design, the fermentation chamber and gas holder are combined as one unit. This design eliminates

the use of costlier mild steel gas holder which is susceptible to corrosion. Its sketch is given in figure (4.6). [34]

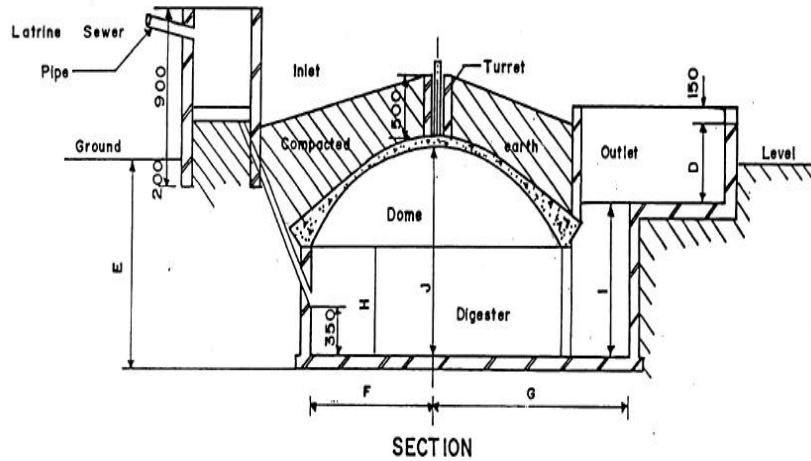

Figure (4.6): Concrete model biogas plant [34].

#### 4.10.3 Deenbandhu Model

Deenbandhu plants are made entirely of brick and work with a spherical shaped gas holder at the top and a concave bottom, this model proved 30% cheaper than Janata model (also developed in India) which is the first fixed dome plant based on Chinese technology. It also proved to be about 45% cheaper than a KVIC plant of comparable size. A typical design of Deenbandhu plant is shown in figure (4.7)

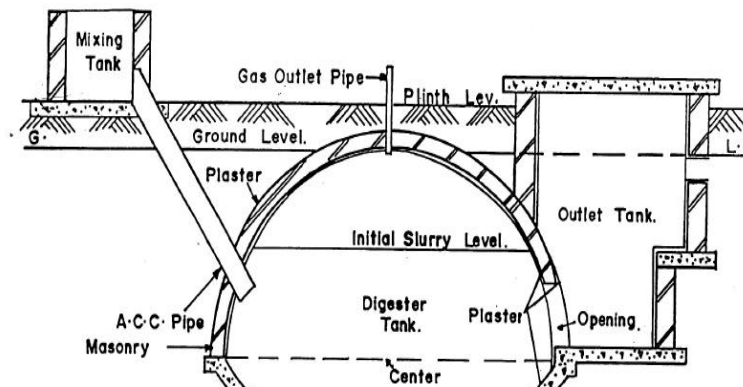

Figure (4.7): Deenbandhu biogas plant ( $3\text{m}^3$  gas production per day) [34].

#### 4.10.4 Bag Digester.

The bag digester was developed to solve the problems experienced with brick and metal digesters.

This design was developed in 1960s in Taiwan. It consists of a long cylinder made of PVC or red mud plastic figure (4.8).

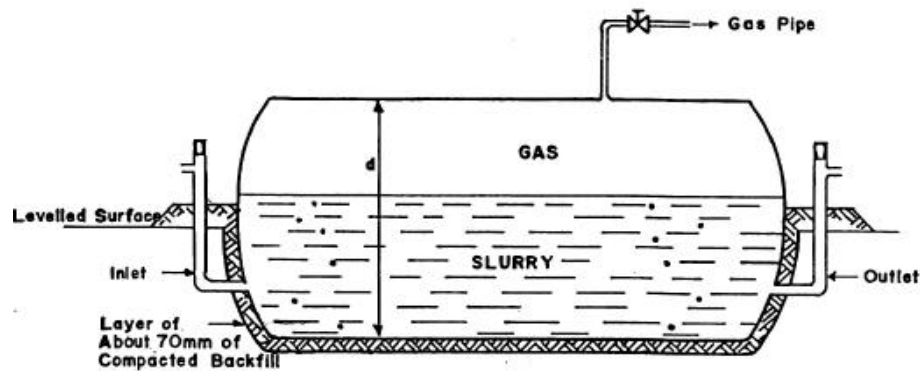

Figure (4.8): Bag digester [34].

#### 4.10.5 Plug Flow Digester.

The first documented use of this type of design was in South Africa in 1957. Figure (4.9) shows a sketch of such a reactor.

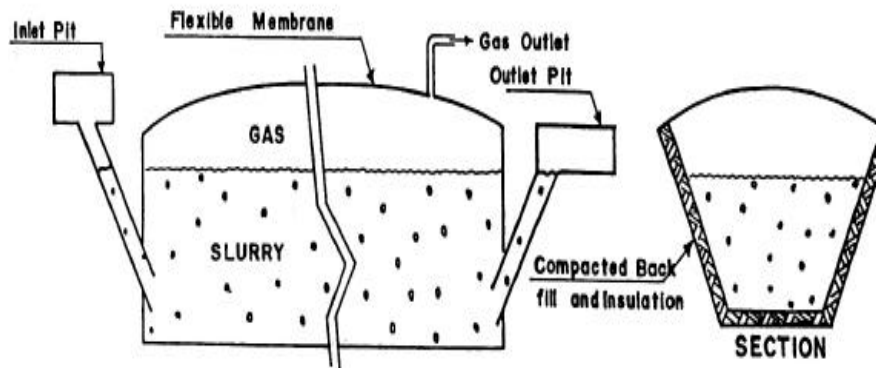

Figure (4.9): Plug flow digester [34].

#### 4.10.6 Anaerobic Filter.

This design is best suited for treating industrial, chemical and brewery wastes. It is one of the earliest and simplest types of design developed to reduce the reactor volume. It has a variety of non-biodegradable materials that have been used as packing media for anaerobic filter reactors such as stones, plastic, coral, mussel shells, reeds, and bamboo rings. This type of digester was developed in the 1950's to use relatively dilute and soluble waste water with low level of suspended solids.

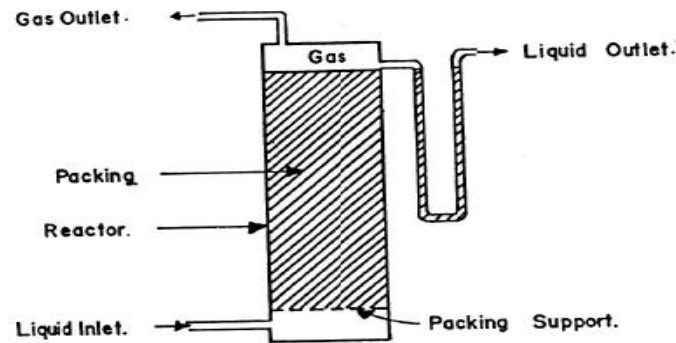

Figure (4.10): The anaerobic filter. [34]

#### 4.11 Inputs and Their Characteristics.

One of the main attractions of biogas technology is its ability to generate biogas out of organic wastes that are abundant and freely available. Any biodegradable organic material can be used as inputs for processing inside the biodigester. However, for economic and technical reasons, some materials are more preferred as inputs than others.

If the inputs are costly or have to be purchased, then the economic benefits of outputs such as gas and slurry will become low. Also, if easily available biodegradable wastes are used as inputs, then that benefits could

be of two folds: (a) Economic value of biogas and its slurry; (b) Environmental cost avoided in dealing with the biodegradable waste in some other ways such as disposal in landfill. The amount of gas production from some animal dung is given in table (4.5).

**Table (4.5):** Gas production potential of various types of dung [33].

<b>Animals</b>	<b>Amount of biogas(liter/kg wet dung)</b>
Dairy cattle	30
Beef cattle	42
Swine	53
Poultry	116

In addition to the animal and human wastes, plant materials can also be used to produce biogas and biomanure, table 4.6 shows the gas yield of some common fermentation materials.

**Table (4.6):** The gas yield of some common fermentation materials [33]

<b>Material</b>	<b>Amount of gas produced/ton of dried material (m<sup>3</sup>/1000kg)</b>
General stable	260-280
Pigmanure	561
Horse manure	200-300
Rice husk	615
Fresh grass	630
Straw	342
Potato plants	260-280
Leaves of trees	210-294

Since different organic materials have different bio-chemical characteristics, their potential for gas production also varies. Two or more of such materials can be used together provided that some basic requirements for gas production or for normal growth of methanogens are met.

**Chapter Five**  
**Potential of Biogas Production**  
**In Palestine**

### **5.1 Potential of Biogas Production in Palestine.**

The climate in Palestine changes from region to region despite the small area. The rainfall in the high regions reaches 510 mm with high humidity and mild temperatures with a mean temperature of 18.5C<sup>0</sup>. While the Jordan Valley has tropical climate and high evaporation rate, the mean temperature in the Jordan Valley reaches 23.6 C<sup>0</sup> and this is the highest mean in Palestine. [35].

At present all of the Palestinian energy needs are met by importing oil products from Israel companies. The prices are very high and usually not affected by the international market price especially when the international prices drop.

Palestinian families are suffering in rural area in disposing off wastes and this emphasized the opinion about negative impacts of wastes on rural families' life.

The suitable solution is building biogas digester at least for each Palestinian farm and home or community – type units. These units are to be shared by neighbors, usually relatives. These units will be fed by combined feed stock of human and animal wastes. Also, these units can be used in public latrines in schools, factories, hospitals.

The yearly amounts of dry organic wastes in Palestine was described in detail in chapter two.

### **5.2 Theoretical Estimation of Biogas Production in North of West Bank.**

Based on the amount of organic wastes which daily received to Zaret Alfinjan land fill) the theoretical amounts of the production of biogas in

north of Palestine can be calculated. Yearly amount that considered as useful organic wastes was (200 ton/day \* 24 day / month \* 12 month /year) (57,600tons/year) out of total waste 115,200tons/year. This means that the estimated amounts of biogas production to be presented are achievable. The production is estimated to be 12 million m<sup>3</sup> of biogas/year. Based on our experimentally work each one kg of organic waste can generates 0.15 kg of bio gas. This amount is equivalent to 8,640,000 kg of biogas, or to 4,320,000 kg of butane gas as heating value. [Equivalent to 360,000 butane bottle/ year (12 kg/bottle)]. With the cost of 55 NIS/bottle \*360,000 bottle = 19,800,000 NIS /Year.

### **5.3 Constructed digesters in Palestine.**

The dissemination of digesters in West Bank and Gaza Strip is extremely little, but some experiments were done.

#### **5.3.1 Jericho Digester.**

This digester was constructed in the spring of 1998 with 5m<sup>3</sup> volume; it could produce about 1m<sup>3</sup> bio gas and 200 L fertilizer daily, it was used for educational purposes but now it is not working [33].

#### **5. 3.2 Jenine Digester Plant.**

This experiment was applied over ground in the most agricultural governorate (Jenin) of Palestine. Moreover; the biogas production for 20 samples of mixed organic wastes (animal dung, food residues and wheat straw) were tested at the same time and in two different digester volumes ( 18 barrels each of 240 Liter capacity, and 2 large steel digesters each of 1500 Liter capacity ) [24].



Twenty samples of organic wastes were introduced and closed for 60 days in twenty digesters (18 barrels and 2 large digesters), and the constant composition of each digester sample with ratio of each organic waste type and water dilution factor are found in table (5.1).

**Table (5.1):** Samples compositions. [24]

N O	Digester	Organic waste weights					Water dilution factor water/waste
		Cow dung weight (kg)	Sheep and goat dung weight (kg)	Chicken waste weight (kg)	Food residues weight (kg)	Wheat straw weight (kg)	
1	B1	2	2	2	3	3	2.5
2	B2	2	2	2	6	0	2.5
3	B3	2	2	2	0	6	2.5
4	B4	0	0	0	6	6	2.5
5	B5	0.999	0.999	0.999	6	3	2.5
6	B6	0.999	0.999	0.999	3	6	2.5
7	B7	3.999	3.999	3.999	0	0	2.5
8	B8	0	0	0	12	0	2.5
9	B9	0	0	0	0	12	2.5
10	B10	3.999	3.999	3.999	0	0	2.0
11	B11	3.999	3.999	3.999	0	0	3.0
12	B12	3.999	0	0	3.999	3.999	2.5
13	B13	0	3.999	0	3.999	3.999	2.5
14	B14	0	0	3.999	3.999	3.999	2.5
15	B15	2	2	0	3.999	3.999	2.5
16	B16	2	0	2	3.999	3.999	2.5
17	B17	0	2	2	3.999	3.999	2.5
18	B18	1.332	1.332	1.332	3.999	3.999	2.5
19	D1	12	12	12	18	18	2.5
20	D2	12	12	12	18	18	2.5

B= Barrel, D1= 1.5 m<sup>3</sup> digester with stirrer, D2= 1.5 m<sup>3</sup> digester without stirrer.  
Water dilution factor means: water volume unit added to each mixed waste volume unit.  
Total weight of organic wastes in each B=12Kg.  
Total weight of organic wastes in each D1 and D2= 72Kg.

### 5.3.2.1 Experiment results

The experiment started on 26/10/2003 and finished on 25/12/2003, for 60 days. The tables and figures below illustrate the measuring results (temperature, pH value, biogas productivity) according to the amounts showed in table 5.1 [24].

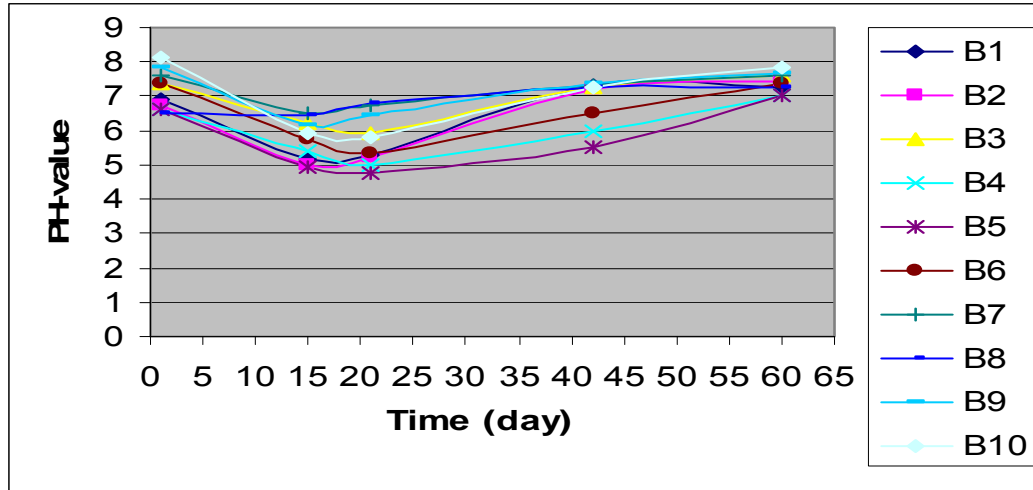

Figure (5.1): PH values with time for the samples from B1 to B10 [24]

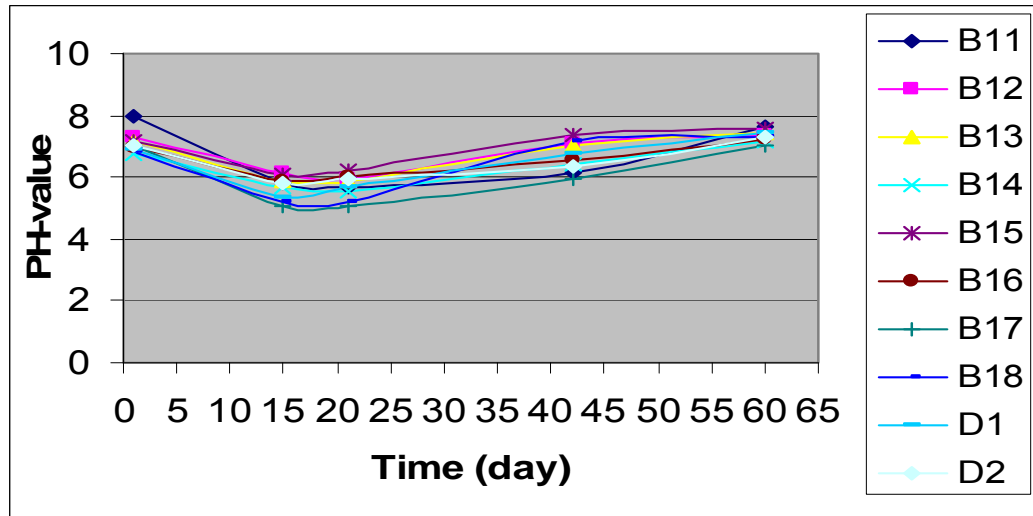

Figure (5.2): PH values with time for the samples from B11 to B18 and D1, D2 [24].

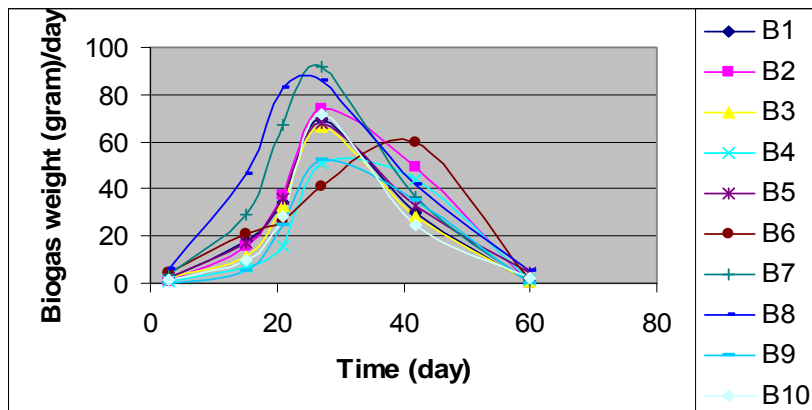

Figure (5.3): Biogas productions with time for Barrels from B1 to B10

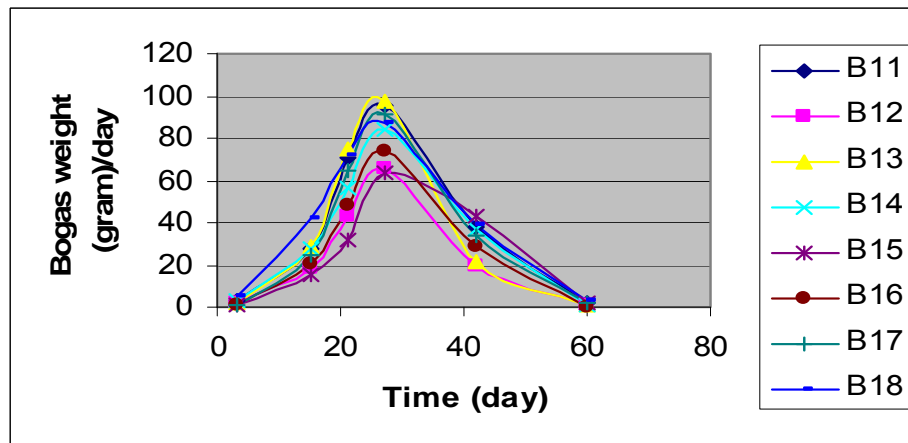

Figure (5.4): Biogas productions with time for Barrels from B11 to B18

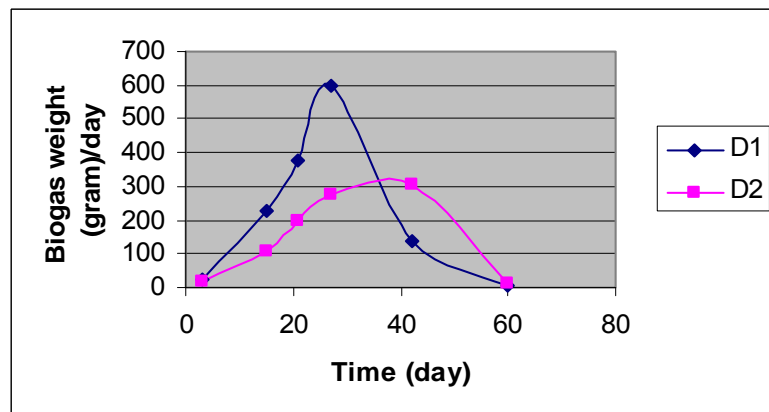

Figure (5.5): Biogas productions with time for Barrels D1 and D2 [24].

### 5.3.2.2 Discussion of the results.

For example the biogas production for 12 kg wastes in B6 is 1.8kg biogas and so the amount of biogas production for 1kg for B6 wastes is  $1.8/12=0.15$ kg biogas, and biogas production for 72 kg wastes in D1 is 13.8kg biogas and so the amount of biogas production for 1kg for D1 wastes is  $13.8/72=0.19$ kg biogas.

**Table (5.2):** Approximated amount of biogas production from one Kg waste for Jenin digesters. [24]

Digester	(Total Amount of biogas in Kg)	Biogas production Kg / Kg waste
B6	1.8	0.15
B8	2.4	0.2
B13	2.4	0.2
B16	1.9	0.16
D1	13.8	0.19
D2	10.8	0.15

### 5.3.3 Khadoury digester/ Tulkarem.

This digester was constructed in the middle of 2000 with 14m<sup>3</sup> digester volume and 3m<sup>3</sup> holder volume that could store 60% from daily biogas production, it was located near the cows farm which belongs to agricultural college of An-Najah National University[17].

Some instruments were used to record data as digital pH meter, thermometer and gas flow meter. Unfortunately this digester was destroyed by Israeli forces but its testing results are shown bellow in figures (5.6) and (5.7). This digester was fed two times the first was 50 L/day and the second time was 100 L/day (1dung:1water) [17].

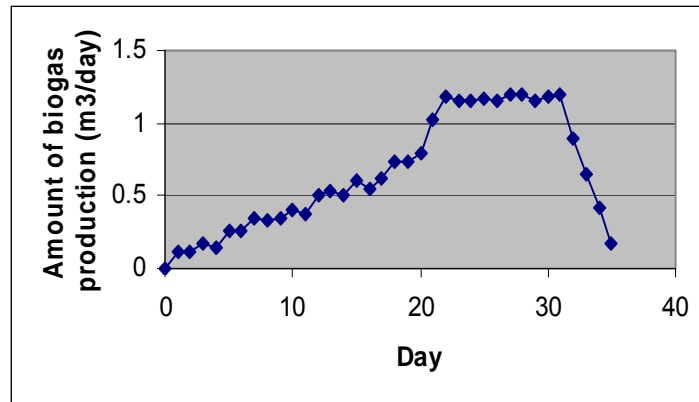

**Figure (5.6):** Biogas production rate  $\text{m}^3$  for 50 L slurry per day for Khadoury digester [17].

In this case the average pH was 7.66; average air temperature was  $33.03^\circ\text{C}$ , slurry temperature  $27^\circ\text{C}$ .

Figure (5.7) presents the result of the daily rate production of biogas for 100 L slurry/day.

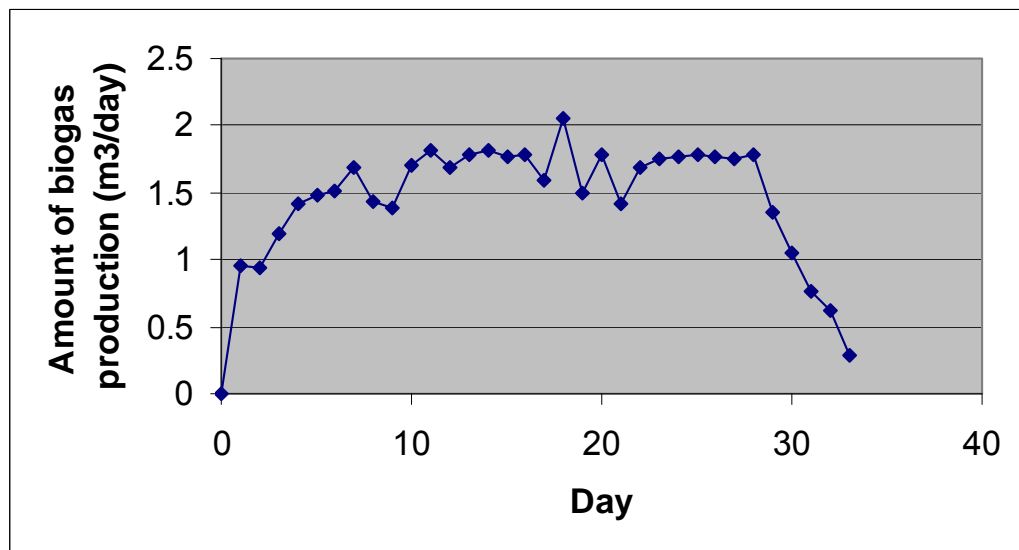
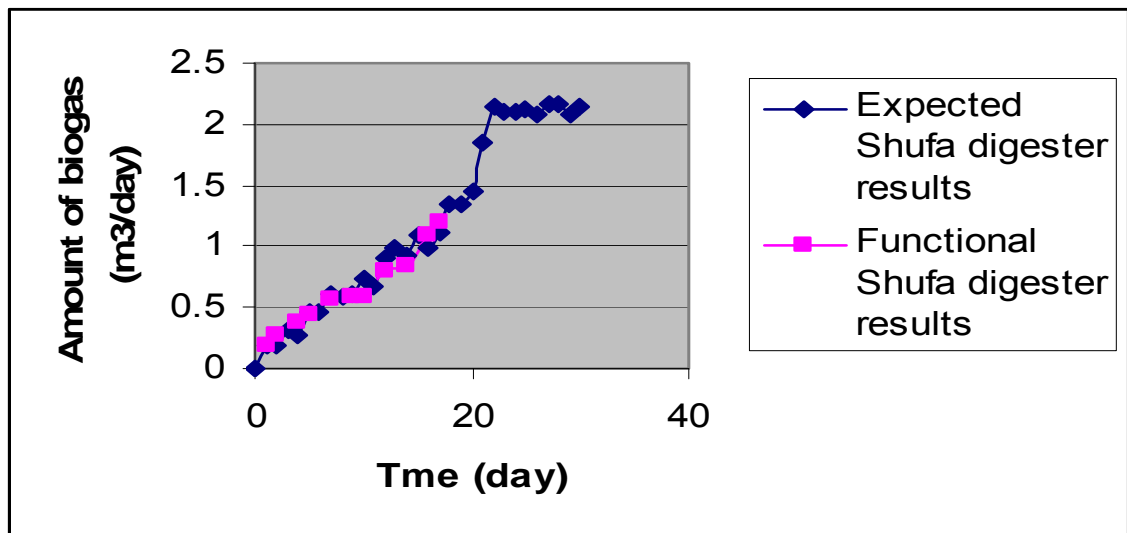

**Figure (5.7):** Biogas production rate  $\text{m}^3$  for 100 L slurry per day for Khadoury digester. [17]

In this case the average pH was 7.68; average air temperature was 33.1 °C, slurry temperature 27 °C.

It is clearly concluded that the daily average of produced biogas for 100 L/day is not equal as double as to that for 50 L/day, for example, at steady state for 100 L/day the amount of produced biogas is 1.75 m<sup>3</sup>/day, while it is 1.17 m<sup>3</sup>/day for 50 L/day, and so it is not doubled

#### 5.3.4 Shufa digester.



**Figure (5.8):** The functional test measurements for daily rate production of biogas in Shufa digester (m<sup>3</sup>/day) [17].

It is clear that the results of functional test measurements for daily rate production of biogas in Shufa digester are similar to the expected results based on Khadoury digester in Tulkarem.

## **Chapter six**

### **Experimental Work**

## 6.1 Experimental Work.

Mansour digester daily feed digester self mixing type was constructed in Jenin City near my home in may 2009 to be as pilot digester for my thesis calculation on organic waste which can be used to design suitable digester for Zahret Al Fingan land fill in Jenin as case study and second digester was built at Nablus Industrial School to be as pilot digester batch type.

## 6.2 Experimental work on daily feed digester.

Experimentally work for mansour digester at my home, was feeded from my kitchen waste with total capacity 240 liter.

### 6.2.1 Digester description.

Two isolating solar water heater drums each 120 liter capacity as show in the flowing diagram and picture, figure (6.1)

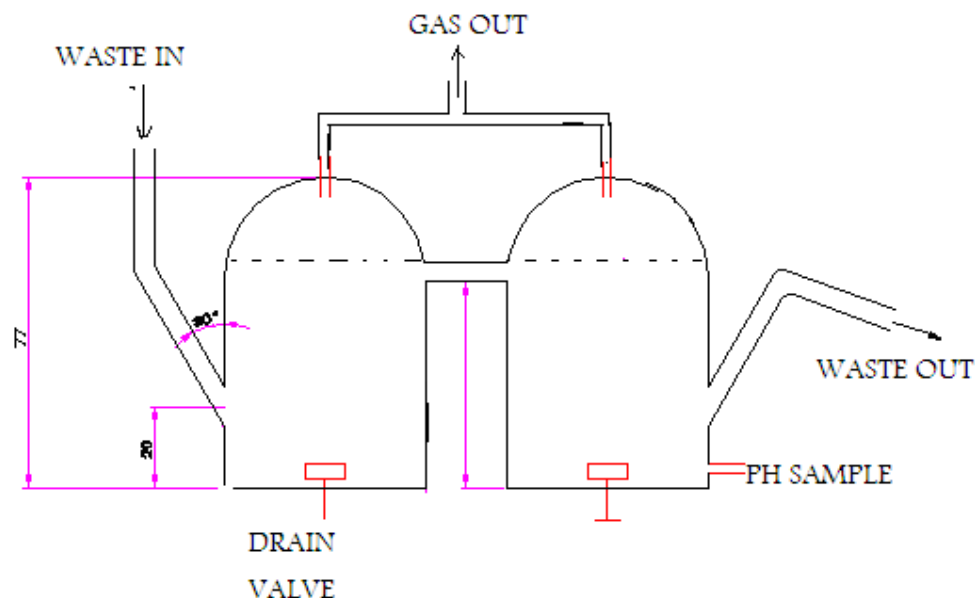

Figure (6.1): Mansour digester.



## 6.2.2 Advantages of Mansour digester

### Slf Mixing Digester

Vertical-mixing digesters consist of vertical chambers into which raw materials are added. The slurry rises through the digester and overflows at the top, as it overflows the top, flows into a second chamber where digestion continues to a greater degree of completion.

In vertical-mixing digesters raw material is subject to a vertical pumping motion and often escapes the localized action of digesting bacteria.

### Continuous-Load Digesters “First-In First-Out”.

This system is unlike other organic waste digestion systems allowing continuous intake of feedstock and continuous removal of output products. With continuous-load digesters, a small quantity of raw material is added to the digester every day.

An even more significant advantage of this system is that the processing speed can be constantly and automatically adjusted to ensure complete digestion of the waste material that passes through it, thereby ensuring that the output products are clean and free of toxic or undigested waste.

### **There are no moving parts, thus nothing can get broke**

A simple design has lower capital costs and technical problems. Low construction and operating costs give potential for a high return on investment from the sale of the output products.



Picture (1): Gas collection by tire tube.



Mansour Digester plant

### 6.2.3 Feeding Amount Calculated.

The appropriate daily feeding amount is calculated as follows:

$$V_{\text{digester}} = t * V_{\text{feed}} \quad [10]$$

$V_{\text{digester}}$  = digester volume ,  $V_{\text{feed}}$  = feed volume ,  $t$ = retention time till the feeding stop assume it is 40 days, About 20% of digester volume as free space for gas , only 100 Liter out of 120 Liter each one was used for our calculation to keep 20 liter as free space for each drum.

Then;  $V_{\text{feed}} = 1/40 * V_{\text{digester}}$  , if ( $V_{\text{digester}} = 200$  liter)

$$V_{\text{feed}} = 200 \text{ Liter}/40 \text{ day} = 5 \text{ L /DAY}$$

I started by 60 liter mixed with manner waste to accelerate gas production and can made more consistent by continuously feeding the digester with small amounts of waste daily.

### 6.2.4 Experiment Results.

The experiment started on 22/8/2009 and finished on 30/9/2009, for 40 days. The tables and figures below illustrate the measuring results (PH value, biogas productivity) according to the result in table (6.1).

**Table (6.1):** Mansour digester results.

	date	Mix L	bio gas(g)	ph	
1	22/Aug/2009	60	0	11	
2	23/Aug/2009	5	0	10	
3	24-Aug-	5	20	8.5	
4	25-Aug-	5	25	8	
5	26-Aug-	5	50	8	
6	27-Aug-	5	80	7.5	
7	28-Aug-	5	100	7.5	
8	29-Aug-	5	120	7.5	
9	30-Aug-	5	150	7	

10	31-Aug-	5	200	7	
11	1-Sep-	5	240	7	
12	2-Sep-	5	300	7	
13	3-Sep-	5	300	7	
14	4-Sep-	5	330	7	
15	5-Sep-	5	330	7	
16	6-Sep-	5	350	7	
17	7-Sep-	5	360	6.8	
18	8-Sep-	5	380	6.8	
19	9-Sep-	5	380	6.8	
20	10-Sep-	5	390	6.8	
21	11-Sep-	5	400	6.5	
22	12-Sep-	5	400	6.5	
23	13-Sep-	5	400	6.8	
24	14-Sep-	5	420	6.8	
25	15-Sep-	5	420	7	
26	16-Sep-	5	360	7	
27	17-Sep-	5	350	7	
28	18-Sep-	5	370	7	
29	19-Sep-	5	350	8	
30	20-Sep-	5	340	8	Start over flow
31	21-Sep-	5	350	8	
32	22-Sep-	5	350	8	
33	23-Sep-	5	330	8.5	
34	24-Sep-	5	330	8.5	
35	25-Sep-	5	350	8.5	
36	26-Sep-	5	340	8.5	
37	27-Sep-	5	340	8	
38	28-Sep-	5	350	8	
39	29-Sep-	5	340	8	
40	30-Sep-	5	340	8	
			11255 g		

The amount of dry waste 100 kg+ 100 liter of water was feeding at the end of 40 days.

The amount of bio gas was produced =11.255 kg

Bio gas in kg / kg dry waste =  $11.255/100 = 0.113$  kg of bio gas /kg of waste

gas production

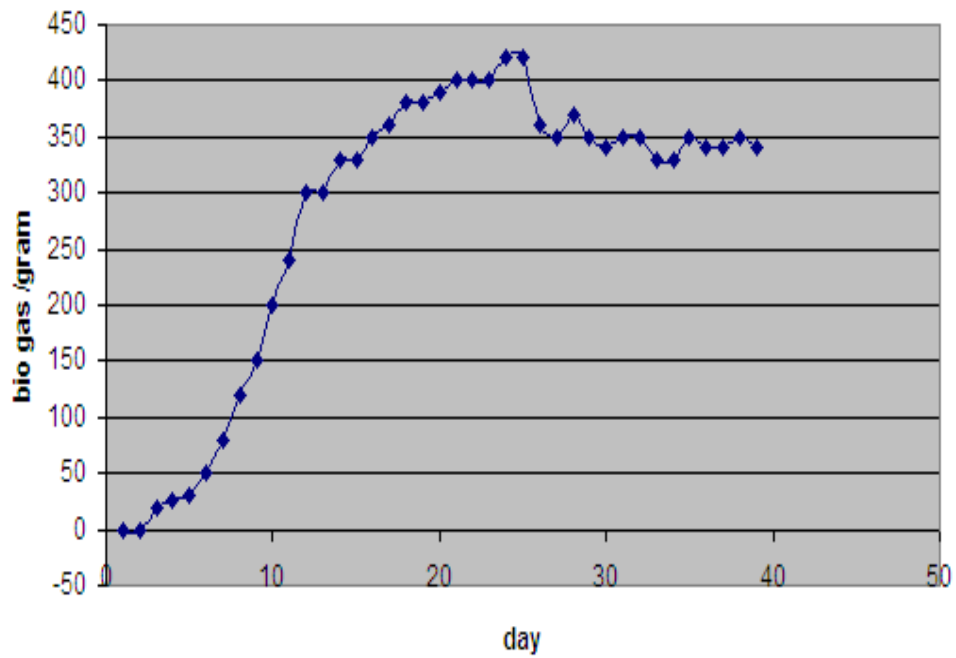

Figure (6.2): The result of the daily rate production of biogas

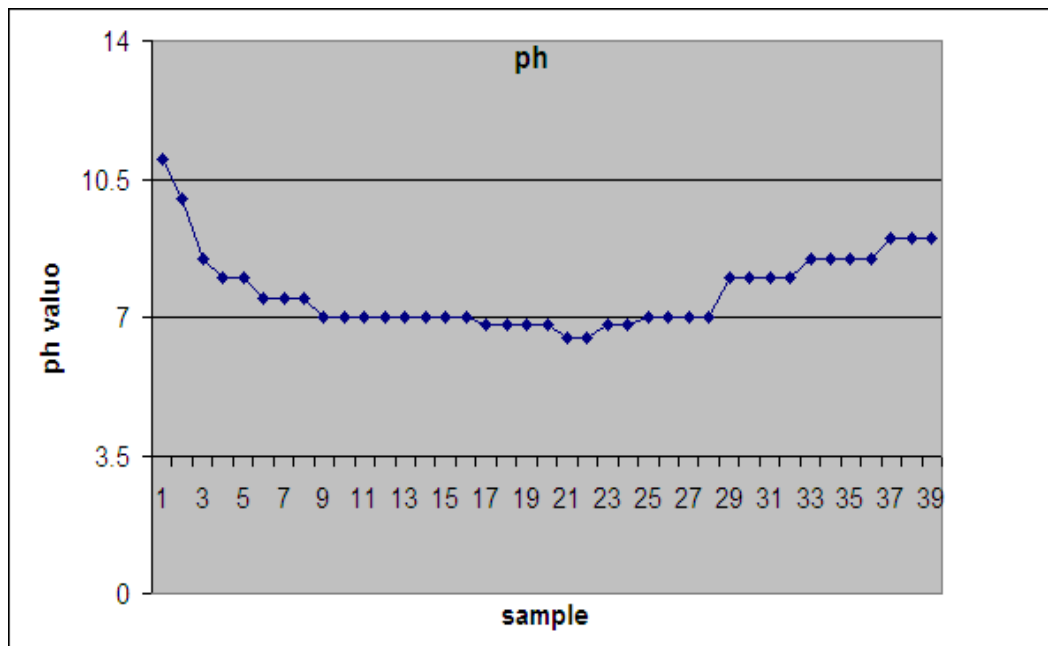

Figure (6.3): The result of the daily pH record.

### 6.2.5 Discussion of the results.

The amount of biogas production for 1kg of organic waste is 0.113 kg biogas / kg organic waste and the best result was as shows if tabl ( 6.2)

**Table (6.2): Best Result**

No of day	date	Liter added	Bio gas / gram	Ph value
22	12-Sep-	5	400	6.5
23	13-Sep-	5	400	6.8
24	14-Sep-	5	420	6.8
25	15-Sep-	5	420	7

After 30 days the digester was full and start over flow liquid from the out put pipe ,as show in table (6.1) I continue feeding the digester for 10 days more and I observed the digester is stabilized and steady producing gas around 350 gram of bio gas/ day with daily feeding 5 liter (2.5 kg waste +2.5 liter water) then I stoped feeding .



**Picture (6)** the Shape and Color of Biogas Flam

### 6.3-Experimental Work With Batch System in Nablus Industrial School

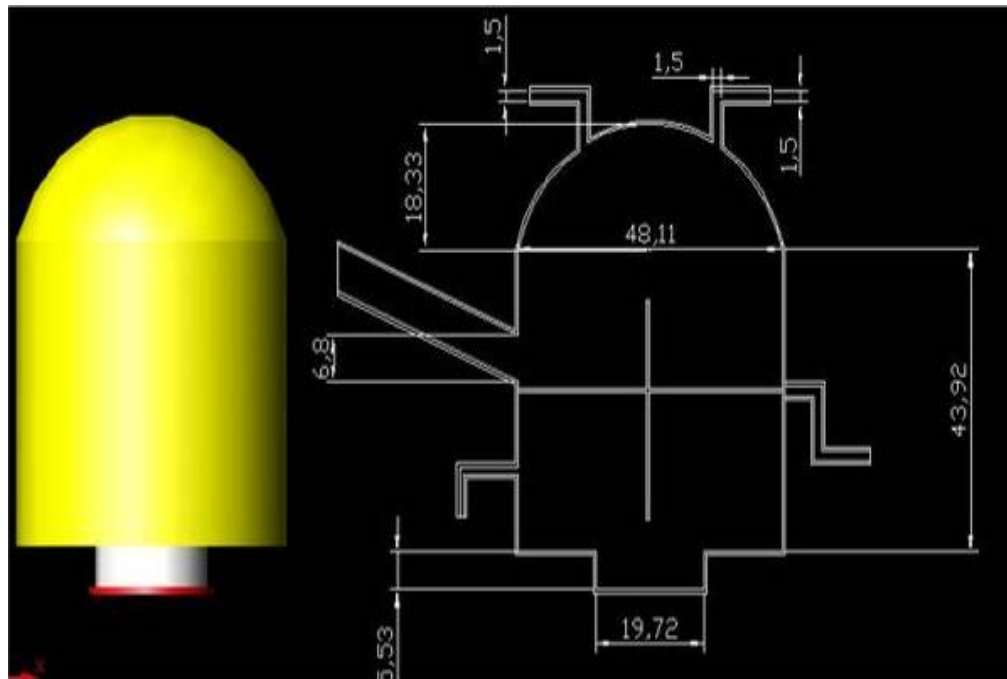
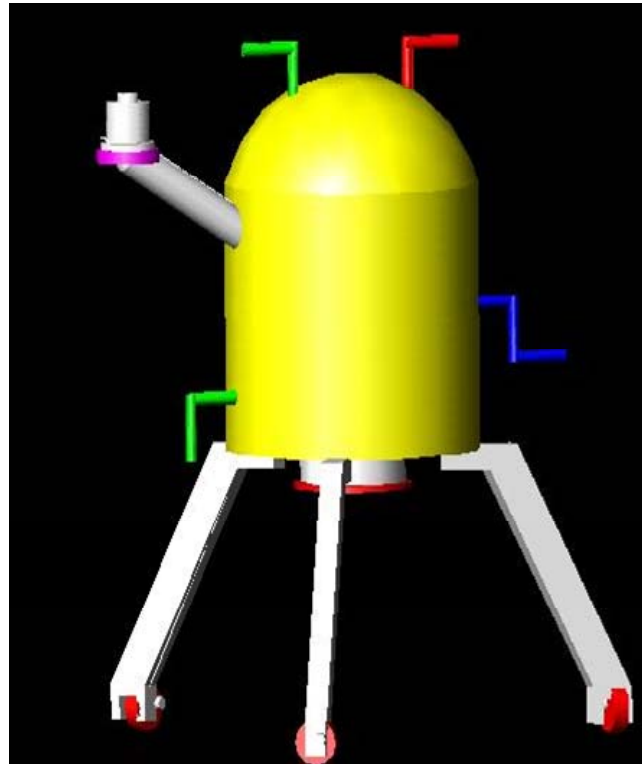
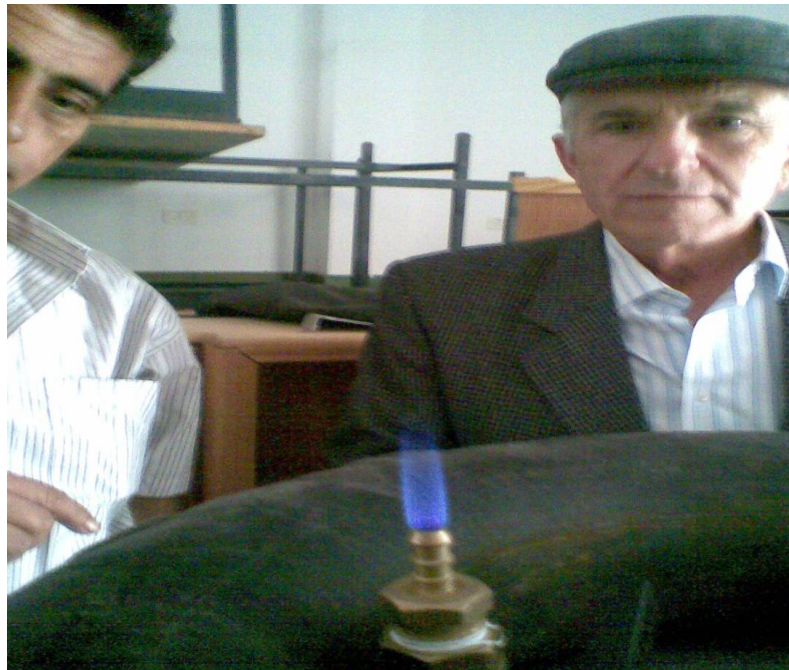

Figure (6.5): N.I.S Digester dimensions





**Picture (8):** Nablus Industrial School Digester



**Picture (9):** Professor Marwan during his Visit to Nablus Industrial School  
Digester





**Picture (9):** Professor Marwan during his Visit to Nablus Industrial School Digester.

### 6.3.1 Nablus Industrial School Digester

Type of digester	Batch system
Capacity of digester	100 L
Dry organic waste	30 kg
Water added	30 liter
Duration time	30 days
Bio gas produced	4920 grams

We started filling this digester by 30kg of different types of organic waste (different types of vegetables, food waste, yard waste), and we used electric mixer to have completely homogenous liquid with 30 Liter of water.

After 30 days we stopped collecting the gas and we generate 4920 gram of biogas/30 days.

### 6.3.2 Discussion of the results.

- 1- At ph value between 6.8 and 7 the best result we recorded.
- 2- From our experimental work, we generate 0.164 kg of biogas /kg as shown in table ( 6.3 ) and figure( 6.6 ).

**Table (6.3):** N.I.S digester result

no of day	date	ph	bio gas /g
1	01-Oct	9.5	0
2	02-Oct	9.5	40
3	03-Oct	8.5	80
4	04-Oct	8	80
5	05-Oct	8	140
6	06-Oct	7.5	140
7	07-Oct	7.5	140
8	08-Oct	7	160
9	09-Oct	7	160
10	10-Oct	7	170
11	11-Oct	7	170
12	12-Oct	7	170
13	13-Oct	6.8	200
14	14-Oct	6.8	200
15	15-Oct	6.8	240
16	16-Oct	6.8	240
17	17-Oct	6.8	240
18	18-Oct	6.8	240
19	19-Oct	6.8	240
20	20-Oct	6.8	230
21	21-Oct	6.8	230
22	22-Oct	7.5	210
23	23-Oct	7.5	210
24	24-Oct	8	210
25	25-Oct	8	170
26	26-Oct	8	170
27	27-Oct	9	170

28	28-Oct	9	150
29	29-Oct	9	80
30	30-Oct	9.5	40
	total bio gas		4920 g

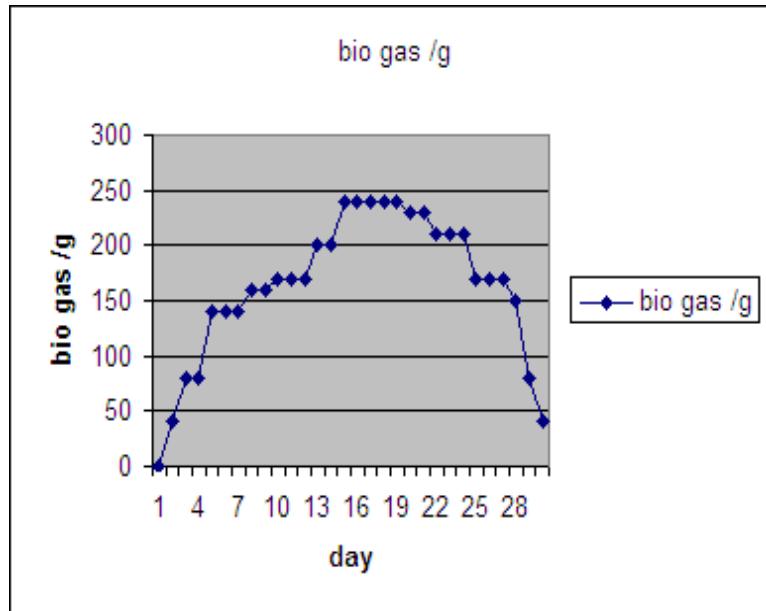

Figure (6.6): bio gas generation from Nablus Industrial school digester

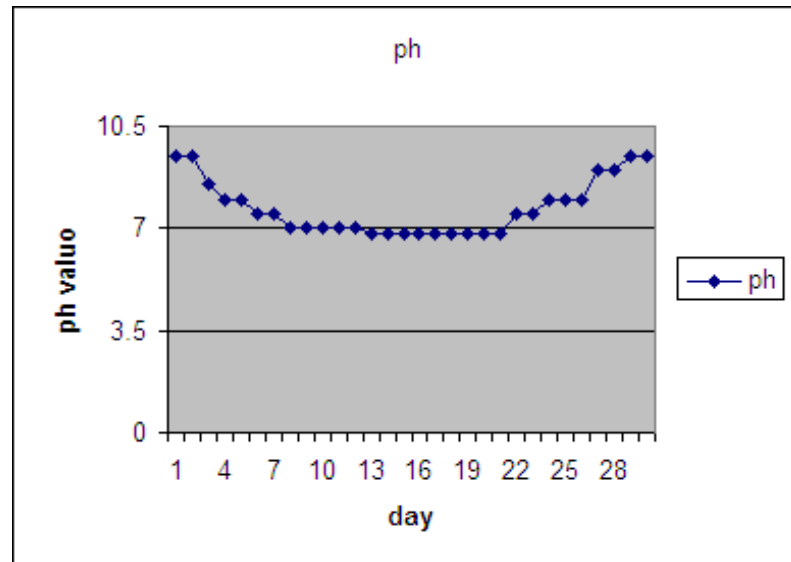

Figure (6.7): PH value from Nablus Industrial school digester.

#### **6.4 Case Study: Jenin Digester At Zahret AL-Fingan LandFill**

Jenin is a quaint governmental of roughly 285000 inhabitants in the north region of west bank the city has fallen on hard economic times. Local leaders are now faced with considerable municipal issues, one of which involves solid waste management. Poor transportation, improper disposal, and a lack of recycling options, complicated by the stubborn mindset of its people, make this problem unique and challenging. Palestinians task of modernizing infrastructure in the coming years has a broad scope involving not only traditional engineering work but education, policy development, and income generation. The motivation for this study is the Zahret Alfingan Landfill in Jenin City at north of west bank.

Their current waste management practices include nearly daily pickup of household trash and medical waste and disposing of it in a sanitary landfill 4 km outside of the Jenin City.

A study performed within the past year has showed that a significant (upwards of 90 %) fraction of their waste stream is organic. There is no heavy industry in the municipality and no hazardous waste produced and thus is a good candidate for biological treatment.

There is a potential to recover energy from anaerobic digestion in the form of methane. This methane can either be flared or combusted in an engine or turbine to produce electricity. There will also be a discussion on the environmental, social and economical impacts of the implementation of a digester in the Zahrat Al finjan landfill.

From the calculations, a range of 3000 to 4000 kWh/day of electricity can be generate by the digester, resulting in enough power to supply 600 to 800 home of the Jenin City if organic fraction only 50%, and 5000kWh/day if organic fraction 90% which is enough power to supply 1000 home of Jenin City.

The environmental impacts will be able to reduce the amount of waste going to the sanitary landfill, convert all Methane emissions to carbon dioxide which has a lower global warming potential. The city will also benefit socially and economically from the pride of a one-of-a-kind solid waste management process for the region and the sale of viable electricity from a biogenic carbon source.

#### **6.4.1 Description of the Study Area.**

Jenin is located in the northern part of the West Bank, at the edge of Marj Iben Amer Governorate; It is considered as the center of the transportation roads coming from Nablus, Al Afula, and Bisan and a transportation point for the roads going to Haifa, Nazareth, Nablus and Jerusalem. This location gives the city strategic importance. The area of Jenin Governorate is 583 km<sup>2</sup> and with Tubas district it becomes 985 km<sup>2</sup>. The population of the Governorate is around 285,832. [14]

Within the framework of the previous studies the average solid waste generation was determined through direct counting and sample measurements of the waste collection vehicles before, during, and after dumping of MSW. The specific solid waste generation in Jenin City is estimated at 1.25 kg per capita and day. In other large urban communities, the solid waste generation is 0.50 kg per capita and day, while in the rural areas the waste generation varies between 0.40 and 0.45 kg per capital and day [14].

Through this study I will take the sample of organic waste form Zahret Al Finjan landfill, which has been constructed to receive solid waste from all local communities in the northern part of West Bank. The results can be used in the future for ZF landfill, and can be applied for different location in Palestine.

The Quantity of waste disposed at the landfill: currently the landfill receives around 400 ton of waste /day coming from Jenin, Tubas, Nablus and some villages of Tulkarem governorate, this quantity will increase to 600 ton after receiving the waste from Qalqiliya and Salfeet governorates , Tulkarem city and the rest of its villages, and the villages of Nablus Governorate.

The number of the citizens who benefit from the project in the northern governorates is around 800,000 person.

The Location: the project is located in wadi ali- wadi d'auq between Arrabeh and Ajja, which was called later Zahrat Al Finjan. It is 17 km south of Jenin city, 25 km west of Tubas, 23 km North of Nablus, 24 km east of Tulkarem and 50 km north of Qalqilyia.

#### **6.4.2 Scope.**

The collection and separation will not be addressed and the design will start with the organic loading rates of the waste. It will then proceed through the optimal conditions considerations (moisture content, pH, temperature), the energy produced from the anaerobic process, options for use of the excess energy, and finally an environmental impact and overall feasibility analysis.

#### **6.4.3 Impact Analysis.**

The impact analysis will focus on environmental impacts as well as the social and economic impacts.

The economic impacts will be addressed more in the capital and Operation. The three steps to be used in environmental impact analysis are classification of emissions (type and emission location), the quantification of those emissions and finally the weighting of the impacts of those quantities.

## 6.5 Why Anaerobic Digestion?

The majority of waste produced in Jenin and north of West Bank which arrived to ZA Land fill from rural cities and many families are still reliant on local farmers and their own gardens for food, creating even more organic waste from crop production and animal feces. This high organic fraction coupled with the fact that there is no heavy industry in the city and towns and no hazardous waste production lends itself perfectly to some sort of biological treatment. The biological treatment options available.

## 6.6 Waste Production.

The average rate of waste generation for a person in west bank from the Ministry of Environment's report is 0.8 Kg/person/day based on observations made in spring of 2008 and the population of the municipality.

From the observations in May of 2008, it was concluded that a conservation estimate of about 90% of their waste stream was organic waste in nature from both residential and commercial sources but 50% was chosen for calculations.

### Eq 6.6.1 [36]

Organic waste production rate =

Waste production (mass per capita/time) \*population \* organic fraction

$$=0.8*800000*0.5$$

$$=320,000 \text{ kg/day organic waste}$$

### 6.6.2 Organic Loading

With the rate of generation of organic waste per day and an assumed value of the Chemical Oxygen Demand (COD) of that waste (grams COD per kilogram of waste), a rate of organic loading into the digester from the solid waste must be calculated. Values for the chemical oxygen demand (COD) will be assumed in the range of 500 to 1000 g/kg. [36]

### Eq 6.6.2 [39]

Solid waste COD = organic waste (mass/time) \* average COD content (mass/mass)

$$= 320000 \text{ kg/day} * 700\text{g/kg}$$

$$= 224,000,000\text{g/day}$$

$$= 224000\text{kg/day}$$

### 6.6.3 Methane Production

Lettinga gives a figure of 0.25 g CH<sub>4</sub> / g COD digested [38].

There are other factors that will affect the quantity of methane formed such as the quality and composition of organics in the waste as well as the type and number of microbes present.[16]

#### Eq 6.6.3[16+39]

Methane produced (mass/time) = COD digested (mass/time) \* 0.25

$$= 224,000,000\text{g/day COD digested /day} * 0.25 \text{ g CH}_4$$

$$= 56,000,000\text{g/day}, = 56,000\text{kg/day of CH}_4.$$

If Methane energy content: 34200 kJ/kg (9.5 kWh/kg biogas)[10]

Then 56000 kg /d CH<sub>4</sub> \* 9.5 kWh /kg = 532000 kWh / day

We can produced as electrical energy = 532 MWh/day

With engine efficiency 0.2 = 532 MWH\* 0.2 / 24

Electrical power = 4.433 MW of power produced.

### 6.7- Assumed Values.

- Population of the north of west bank: 800 000 persons.
- Waste produced: 0.8 kg /person/day.
- Methane production: 0.25 g CH<sub>4</sub>/g COD removed
- Methane energy content: 34200 kJ/kg (9.5 kWh/kg biogas)
- Combustion engine efficiency: 20 %



## **6.8 Discussion of Results.**

The bottom line of energy produced from the combustion of the Methane from the digester, values range from about 4000 to 5000 kWh/day. If one house needs 5 kWh /day, then this power enough to supply around 1000 home/ daily. With approximately 10,000 homes in the municipality, this would power 10% of Jenin City load.

### **6.8.1 Impacts and Feasibility.**

#### **- Economical.**

There are many economic considerations in anaerobic digestion from the initial capital cost to operation and maintenance of the system to the disposal and/or use of the by-products.

The initial capital cost and annual operation and maintenance must be affordable enough to use funds provided by the community of Jenin City through International Aid Organizations such as the World Bank, Rotary International or the United States Agency for International Development (USAID), or a combination of the three.

There will also be a requirement for workers at the site for loading the waste into the digester, possible sorting, and monitoring of the whole process. There are possibilities to gain profit from the digester, sale of both electricity from the combusted Methane as well as the sale of the inert and nutrient-rich sludge that is produced from the nature of the design of the digester,

#### **- Environment.**

##### **1- Land Disposal.**

An obvious benefit to using the anaerobic digester will be the reduction of organic waste going to the municipal dump. Any reduction of that waste will be beneficial to the neighboring villages currently complaining of the fumes emitted from the site. Another hazard with the current practice is the possibility of vector attraction, brought upon mainly

from the organic waste. Mammals and birds are attracted to the decaying waste for food and could bring disease to people.

## **2- Global Warming Potential Reduction.**

With the current landfill practice, under the surface layer of waste there is organic waste under anaerobic conditions, which will produce Methane and Carbon Dioxide, just as in a digester. As this process takes place, methane is released to the atmosphere and Methane has a Global Warming Potential (GWP) 12 times greater than Carbon Dioxide. If an anaerobic digester is implemented, the Methane could be either flared or sent to an internal combustion engine for energy recovery; both options would produce Carbon Dioxide from the Methane produced.

**Chapter Seven**  
**Design of a Family Digester and Its**  
**Economic Evaluation**

## **Design of a Family Digester and Its Economic Evaluation**

A family Biogas producing system will be proposed depending on the implemented experiments and Palestinian environmental conditions. In addition to cost of the construction materials and pay back period of the biogas plant will be calculated.

### **7.1 Family Digester Design**

#### **7.1.1 Sizing the Digester**

Most systems use animal manure as a major feedstock, but vegetable, food waste and human wastes can be used. Most home systems are of the continuous feed type, as you can add to them daily.

The Methane production process consists of a large tank or digester where the Methane is produced, stirrer, and a gas storage tank.

The monthly gas requirement dictates the amount of daily input. So, say we need 12 kg of Butane  $C_4H_{10}$  (one bottle )monthly for cooking. This would amount about 24 Kg of Biogas, so daily input needs to be able to produce 24 kg of Biogas /month.[10]

So, once you figure out how much input is required per day, then you can size your digester. Daily volume multiplied by 40 is a good figure for digester size. This will give the material 40 days to digest. You will also have output daily in this same volume, you will need to add water to the input daily as well, so if you could reasonably reuse some of the water that is discarded daily, this would increase the efficiency of the system.

The digester must be kept at a constant temperature. This is best done with good tank insulation and a solar water heater. The best temperature between  $30\text{ C}^\circ$  and  $37\text{ C}^\circ$  degrees.

As the gas is produced, it needs to go somewhere. The gas will be stored in very low pressure, which is fine, and safe. You can then route the gas from the storage tank to the house using black poly pipe or PVC. Since we are working with low pressures, expensive pipe is not needed.

The system will take some time to get a decent population of bacteria started in the tank, and this can be helped along by adding cow and/or human manure at the beginning, as both contain the bacteria needed.

This system can be sized to fit any need, but is most efficient for cooking and/or heating water. It could be used for electricity generation through a gas generator.

From our experimental work we found about 0.15 kg of bio gas in minimum rate can be produced from each one kg of dry organic waste.

Then if we need 24 kg of bio gas to be equivalent to one bottle of butane (12 kg) based on calorific value of butane is double of calorific value of bio gas, which can be enough for one home during one month.

Amount of dry waste needed per month=

$$24 \text{ kg biogas} / 0.15 \text{ kg biogas} / 1 \text{ kg dry waste} = 160 \text{ kg waste} / \text{month}$$

Note a tone (1000kg) of water has a volume of 1 cubic meter (1000Litres) by definition. For most approximations, liquid food and farm wastes have a density close to that of water.

If we used the ratio 1: 1 water to be added then we need 160 liter of water to be added to our 160 kg of organic waste then the total volume we need 320 liters.

Tank Volume = Volume of mixture + 20% of mixture volume for gas space

= volume of mixture (1+0.2)

= 320 Liter (1.2) = 384 Liter,

(SAY 500 Liter) tank volume we need

= 1/2 m<sup>3</sup> tank volume will be good choice

Most home systems are of the continuous feed type, as you can add daily waste.

## 7.2 Daily Feed Quantity as Continuous Feed Type

Daily volume multiplied by 40 is a good figure for digester size then we need 400 Liter during 40 Days , then  $400/40 = 10$  Liter we need to add daily, and if we start with 80 liters(40L water + 40 kg cow and/or human manure) at the beginning, as both contain the bacteria needed.

Then we need daily feeding =  $320 \text{ liter} / 40 \text{ day} = 8 \text{ Liter} / \text{day}$  as liquid.

This means that we need 4 kg of organic waste /day + 4 liter of water/day.

## 7.3 Batch system.

Mostly anaerobic digesters for the treatment of organic solid waste are batch or one stage digesters. The batch digesters a closed or domed vessel moreover, these batch type plants are not suitable for the treatment of large quantities of solid organic waste. Single stage digestion is a simple design with a longer track record, and has lower capital costs and technical problems.

## 7.4 The family digester design

To select the appropriate digester with simplest design, single stage digestion, low construction cost and lower technical problems that could be operated and repaired by the family itself.

The best choice is a Batch System with total volume 500 liters. The proposed design of family digester is shown in the figure (7. 1).

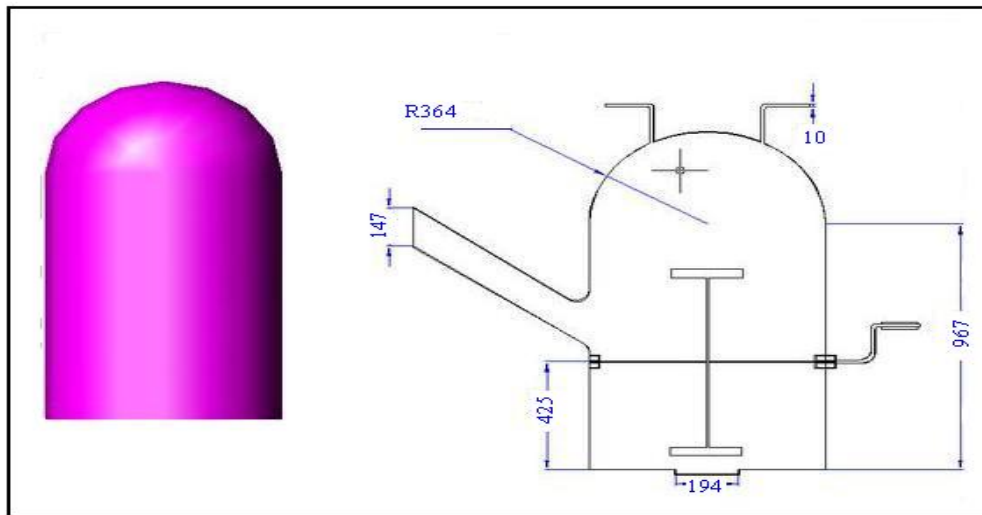

**Figure (7.1):** Sketch of a family digester in Palestine ( $0.5 \text{ m}^3$ )

Dimension in mm.

## 7.5 Economic Analysis

### 7.5.1 Capital cost.

The costs for constructing the proposed design of the family biogas plant may be estimated as follows:

**Table (7.1):** Requirements and costs for constructing the family design

Requirements	Cost (NIS)
Digging operation	500
1/2 cubic meter drum(0.4mm)	500
2 rigid plastic pipes	50

Gas valve and connectors	200
Steel non return valve)	200
Miscellaneous	100
Total	1550

### 7.5. 2 Running cost

The annual running costs are:

1- Annual running cost to operate the digester

=10% of digester cost [37] + water cost

= 155NIS +30NIS = 185 NIS /Year

(30NIS) water cost/year =200Liter/40day \* 365 day/year=1825 Liter/Y  
about 2 m<sup>3</sup> of water which cost 30 NIS)

### 7.5.3 Biogas profit

Profit of produced biogas

= (55 NIS / one butane bottle /month) \* 12 month/Year

=660 NIS /Year.

### 7.5.4 Fertilizer Profit.

Price of 1 ton fertilizer 200 NIS/Ton

Yearly fertilizer produced = 200kg /40 day x 365 day /year

= 1825 kg/year

= 1.825 ton/year

Yearly fertilizer profit = 1.825ton x 200 NIS



$$= \frac{98}{365} \text{ NIS/year}$$

**7.5.5 Total income/Year** = biogas profit+ Fertilizer profit [37]

$$\text{Total income/Year} = 660 + 365$$

$$\text{Total income/Year} = 1025 \text{ NIS/year}$$

**7.5.6 The profit /year** = income profit – running cost [37]

$$\text{The profit /year} = 1025 - 185$$

$$\text{The profit /year} = 840 \text{ NIS / year}$$

**7.5.7 The Simple Bay Back Period**

$$= \text{capital cost /annual profit [37]}$$

$$= 1550 / 840 = 1.8 \text{ year}$$

This means, the rural family will get back the capital cost within a time period less than tow years which is a reasonable period.

### Conclusions:

1. The suitable family digester type is the single stag patch digester with  $V=0.5m^3$ . This will make a benefit of 840NIS/year and the simple pay back period of it is less than two years.
2. Under ideal conditions temperature  $35^{\circ}C$ , pH value 6-7, and retention time 40 days in Palestine, it is possible to produce about 0.15 kg of gas per kg dry waste at atmospheric pressure.
3. From the calculations, a range of 4000 to 5000 kWh/day of electricity can be generated by the digester according to 400 ton/day received to Zahret Alfingan land fill with organic fraction 50%, resulting in enough power to supply 800 to 1000 home of Jenin City daily load.
4. Biogas is a source of renewable energy usually contains about 50 - 70 %  $CH_4$ , 30 - 40  $CO_2$ , and other gases , it has a heat value of 34200kJ/kg ( 9.5 kWh / kg ) which equals 1/2 heat value of  $C_4H_{10}$  gas .

### **Recommendations:**

1. More researches and practical studies have to be done to improve biogas plant in our country.
2. The PNA has to fund most of digesters which can build in rural areas with good cooperation between farmers and related sectors as energy, environment and agricultural sectors to improve and apply digesters in Palestine.
3. Every Landfill in Palestine is advised to build Biogas Plant by cooperation with related sectors as energy authority.
4. Strong backing in the new Waste Strategy should mean that we start to fulfill this potential, with the widespread introduction of food waste collection management and the construction of more AD plants across the west bank

### **Series Activities Recommended to the Community as a Course of Action.**

- 1- Environmental contamination assessments and setting a new disposal facility.
- 2- Development of a community education promotion program.
- 3- Evaluation of local and regional recycling market.
- 4- Waste collection optimization, and implementation of a regional waste management.

**References:**

1. Journal of Environmental Engineering. **Vol. 127, No. 3**, March 2001, pp. 240-248.
2. Water Environment Research. **Volume 74**, Number 5, September/October 2002, pp. 480-487.
3. Steven Safferman. **Green Project Alternatives for Food Processor's** Michigan State University, December 2006.
4. Usama Zaher, Dae-Yeol Cheong, Binxin Wu, and Shulin Chen. **Producing Energy and Fertilizer From Organic Municipal Solid Waste** Department of Biological Systems Engineering ,Washington State University, June 26, 2007 .
5. Karena Ostrem Advisor Prof. Nickolas J. Themelis. **Greening Waste: Anaerobic Digestion For Treating The Organic Fraction Of Municipal Solid Wastes** MAY 2005.
6. [http://www.biostarsystems.com/anaerobic\\_digestion.html](http://www.biostarsystems.com/anaerobic_digestion.html).22/12/2008.
7. <http://www.arbi.ch/ADsw.pdf> ,23/12/2008
8. Anaerobic Digestion of Solid Waste II Selected Proceedings of the **2nd International Symposium on Anaerobic Digestion of Solid Waste**, Barcelona, Spain, 15-18 June 1999.
9. Biotechnology and Bioengineering, **Vol. 81, No. 1**, January 5, 2003.
10. Prof. Marwan M.Mahmoud, **Lecture of renewable energy 2**, Tuesday, February, 2007.

11. [http://tonto.eia.doe.gov/kids/energy.cfm?page=biomass\\_home-basics.22/4/2009](http://tonto.eia.doe.gov/kids/energy.cfm?page=biomass_home-basics.22/4/2009).
12. The Energy Research Centre at An-Najah National University (ERC) is carrying out, since Feb 2000; **measurements on solar radiation intensity**.
13. Mhmoud Ismaeel. **Simulation of aHybrid Power System Consisting of Wind Turbne , PV,Storage Battery and Diesel Generator Msc thesis** Supervisor Prof. Marwan Mhmoud, An Najah National University OCT 2008.
14. Palestinian central bureau of statistics, [www.pcbs.gov.ps](http://www.pcbs.gov.ps),20/5/2009.
15. Dr. Laurie McNeill Course. **Solid Waste Management**, An Najah National University, Feb, March, April, 2008.
16. Lettinga, G., et. al.. (1999) **High-Rate Anaerobic Treatment of Wastewater at Low**.
17. Ayoub Mohamed Eshraideh **An Educational Biogas Prospect in Tolkarm Msc thesis**, Supervisors Dr Muneer Abdoh, Dr Abdellatif Mohamed, An Najah National University, April, 2002.
18. <http://ptcl.chem.ox.ac.uk/~hmc/hsci/chemicals/methane.html> (methane) 5/8/2008.
19. Arthur Wellinger. **Energy from biological conversion of organic waste**, Switzerland.
20. Anaerobic Digestion Out looks for Msw Streams Biocycle August 2007, **Vol. 48, No. 8**, P. 51.

21. **Evaluating AD System Performance for MSW Organics,** November 2006 and **“Managing AD System Logistics for MSW Organics,”** December 2006.
22. **Source Separated Organics as Feedstocks for Digesters,** August 2005.
23. <http://www.iea-biogas.net/Dokumente/Brochurefinal.pdf>, 14/9/2009
24. Medyan Adel Mustaffa Hassan. **The Feasibility of Biogas Production from Mixed Organic Wastes in Palestinian Rural areas,** Msc thesis, Supervisor Prof. Marwan Hadad, An Najah National University.
25. **Updated Guidebook on Biogas Development-Energy Resources Development Series** (1984), No. 27. United Nations. New York, USA.
26. Reese S. Thompson. **Hydrogen Production By Anaerobic Fermentation Using Agricultural and Food Processing Wastes Utilizing A Two-Stage Digestion System,** Utah State University, 2008.
27. <http://water.me.vccs.edu/courses/ENV149/lesson4b.htm>
28. Read online lecture, Chapter 4 in textbook, **Operation of Wastewater Treatment Plants, Vol. 1.**
29. Karki, A. B., K. M. Gautam and A. Karki. (1994) **Biogas Installation from Elephant Dung at Machan Wildlife Resort,** Chitwan, Nepal. Biogas News letter, Issue No. 45.

- 30.L. John Fry. **Methane Digesters for Fuel Gas and Fertilizer With Complete Instructions for Two Working Models.**
- 31.**The Biogas Technology in China** (1989) Chengdu Biogas Research Institute, Chengdu, China.
- 32.Lagrange, B. (1979) **Biomethane 2: Principles – Techniques Utilization.** EDISUD, La Caiade,
- 33.Palestinian Agricultural relief Committees (PARC) ,(http://www.pal-arc.org/).11/11/2008
- 34.Singh, J. B, R. Myles and A. Dhussa. (1987) **Manual on Deenbandhu Biogas Plant.** Tata McGraw Hill Publishing Company Limited, India.
- 35.Dr. Abdul Malk Al Jaber. **Prospects for Biogas Technology in the Palestinian Occupied Territories,** November 1992.
- 36.Scott M. Keddy. **Anaerobic Digestion of the Organic Fraction of Municipal Solid Waste,** University of Florida, Department of Environmental Engineering Sciences, December 2006.
- 37.Leland, P.E., Anthony Tarquin, P.E.. **Engineering Economy,** McGraw-Hill companies, fourth edition, 1998.

## Appendix:

### Appendix-A

Bingemer and Crutzen, 1987; p. 2183

#### How to Estimate Biogas from Anaerobic Digestion of Organic Solid Waste?

##### STEP 1 - Estimate the biogas potential of the organic solid waste

The main determinant of the amount of biogas is the amount of carbon in the organic waste. When the waste degrades some of the carbon becomes part of the cellular material of the microbes (assimilated carbon) and the rest of the carbon forms methane and carbon dioxide (dissimilated carbon). The more anaerobic the process, the more of this carbon is converted to methane.

The amount of carbon is expressed in terms of the percentage of fresh weight. These percentages are:

- Paper and paperboard 40
- Textiles 40
- Wood and straw 30
- Garden and park waste (green waste) 17
- Food waste 15

Assume that recyclable materials like paper and paperboard and textiles are withdrawn, and that there is no wood and straw waste. The organic waste is comprised of green waste and food waste. Further assume that the waste is 50 per cent green waste and 50 per cent food waste. Then for each kilogram



of fresh waste 0.085 kilograms of carbon from the green waste and 0.075 kilograms of carbon from the food waste are available to form biogas, a total of 0.16 kilograms of carbon.

There are two basic types of anaerobic bacteria, mesophilic and thermophilic, that function at different temperatures. The mesophilic range is 35-37°C and the thermophilic range is 55-57°C. Thermophilic processes are more expensive to get up to and maintain at operating temperature, so assume that mesophilic bacteria are used and the temperature of the anaerobic digester is 36°C. However, thermophilic process has an advantage in that they partially sterilise residues and have a greater methane yield and thus should be examined as an option. The amount of carbon available for biogas formation can be calculated from the following equation:

$$C_{oe}/C_o = 0.014T + 0.28$$

Where  $C_{oe}$  is the amount of carbon available for biogas formation,  $C_o$  is the total amount of carbon, and  $T$  is the temperature. At the temperature of 36°C:

$$C_{oe}/C_o = 0.014 \times 36 + 0.28 = 0.784$$

That is, 78.4 per cent of the carbon is available for biogas formation. We know that  $C_o$  is equal to 0.16 kilograms, therefore:

$$C_{oe} = 0.784 \times 0.16 = 0.12544$$

Of the total amount of carbon per kilogram of the waste, 0.12544 kilograms of carbon is available to form biogas. For the preliminary calculation,

assuming that all of this carbon is converted to methane, and using the fact that the molecular weight of methane is 16 comprising 12 units of carbon and 4 units of hydrogen, then for each kilogram of waste:

Quantity of methane =  $16/12 \times 0.125 = 0.17$  kilograms of CH<sub>4</sub> per kilogram of waste.

### **STEP 2 - Estimate the energy that could be produced and the value of the energy**

Now the energy potential per m<sup>3</sup> of methane is approximately 33,810 kJ per m<sup>3</sup>. This implies that the energy potential of 1 kilogram of methane is 50,312.5 kJ per kg CH<sub>4</sub> using a conversion factor of 0.672 kg per m<sup>3</sup>.

The energy potential per kg of organic solid waste is:

$$= 0.17 \times 50,312.5 \text{ kJ}$$

$$= 8,553 \text{ KJ /kg organic waste}$$

The maximum energy potential of the methane produced per kg of the organic solid waste, based on the assumed composition is 8,553 kJ.

### **STEP 3 - Compare the value of the energy produced with an estimate of the project's costs**

To convert 8,553 kJ to kilowatt hours (kWh) you need to divide by 3,600 because one kWh equals 3,600 kJ.

Number of kWh per kg of the organic solid waste, based on the assumed composition is  $8,553 \text{ kJ} = 2.38$

If the energy is sold at 7 cents per kWh, the energy per kg of waste is worth 16.7 cents. If the cost of the project is less than 16.7 cents per kg of waste processed, this implies that the project is viable.

#### **STEP 4 - Estimate the greenhouse benefit**

If this waste were to be disposed to landfill, not all of the available carbon would be converted to methane. Assume that 50 per cent would be converted to methane. The greenhouse saving per kilogram of waste is 0.085 kg.

Multiply this by 21 to derive the CO<sub>2</sub> equivalent emissions.

For each kilogram of waste the greenhouse saving is 1.785 kg of CO<sub>2</sub> equivalent emissions.

## **Appendix-B**

### **Jenin Joint Services Council for Solid Waste Management**

#### **Work Plan**

Based on the approach of the Joint Services Council for Solid Waste Management to provide distinguished service and a clean urban environment to the citizens of Jenin Governorate, the project implementation unit (PIU), worked hard to develop the cleanliness services and increase the environmental and the healthy level in all the local communities within the Governorate. The exerted efforts concentrate on the development of cleanliness services during the next coming years, these services include collection and transfer of waste to maintain the aesthetical side of all local communities and reach to high level of cleanliness and beauty.

Due to the importance of the waste treatment which is considered one of the most important support services to the cleanliness work and in order to achieve the council program to treat the waste starting from its production until its disposal, Zahrat Al Finjan Sanitary Landfill was constructed where the waste is treated through the burial process, in a way that doesn't cause any pollution to the water and the soil.

#### **Solid Waste Management Project**

Zahrat Al Finjan Sanitary Landfill and the Joint Services Council-Jenin Governorate

### **Zahrat Al Finjan Landfill**

In 1998 a comprehensive approach to improving waste management services in the West Bank was initiated under the Solid Waste and Environmental Management – Project ( Swemp), which recommended the need to improve the waste disposal methods and the management of the waste collection service since both issues increase the possibility of improving the environmental condition in all the West Bank.

The draft prepared under Swemp included defined recommendation for the direct development of the waste services:

1. The construction of regional /strategic, sanitary landfill in Jenin Governorate which was later on and according to the strategy of the Environmental Quality.

Authority and the approval of the Ministry of local Governments and the Joint Service Council in the Governorate became a central landfill to the governorates north of the West Bank.

2. The closure of all random dumpsites.

3. The development of a complete system for the collection and transfer of solid waste, this includes purchasing collection vehicles , containers and other related equipment.

4. Providing financial support for the waste collection service and the operation of the landfill.

The Quantity of waste disposed at the landfill: currently the landfill receives around 400 ton of waste /day coming from Jenin, Tubas, Nablus and some villages of Tulkarem governorate, this quantity will increase to 600 ton after receiving the waste from Qalqiliya and Salfet governorates , Tulkarem city and the rest of its villages, and the villages of Nablus Governorate.

The number of the citizens who benefit from the project: the number of the citizens who benefit from this project in the northern governorates is around 800,000 person.

The Location: the project is located in wadi ali- wadi d'aouq between Arrabeh and Ajja, which was called later Zahrat Al Finjan. It is 17 km south of Jenin city, 25 km west of Tubas, 23 km North of Nablus, 24 km east of Tulkarem and 50 km north of Qalqilyia.

**Jenin and Tubas Joint Services Council for Solid Waste Management:**

\* Based on the requirement of the World Bank for the construction of Zahrat Al Finjan Sanitary Landfill, a board of directors was formed in Jenin and Tubas governorates, The council was established in accordance to the system of the Joint services councils N (1) of 1998.

\* The bylaw of the council was approved by the Minister of local government on 25/9/2000.

\* The council includes most of the local communities within Jenin and Tubas region while the board of directors consists of 15 Municipalities, 5 village councils ,3 of them are elected every 2 years.

**The main tasks of the council:**

- Prepare the suitable plans, control waste collection and transfer process, prepare integrated plan to get rid of the waste in engineering way.
- Construct a sanitary landfill; this includes providing sufficient maintenance and facilities to control the operation within the landfill.
- Collect the waste from the containers.
- Construct and operate a garage to the joint collection vehicles.

- Operation and maintenance of the waste vehicles which belong to the council in addition to providing maintenance to the vehicles which belong to the council members taking only the cost of the technician and the maintenance workers.
- Increasing and maintenance of the collection containers in the various local communities (members of the council).
- Provide training to the waste collection, transfer and disposal team.
- Organize public cleanliness campaigns according to the request of the council members.
- Conduct public awareness campaigns.
- Provide advice and guidance to the local communities (members of the council) regarding the solid waste management.
- Represent the local communities (members of the council) in front of any party in the cases related to solid issues.
- Prepare the plans and apply all the methods that minimize the pollution caused by the solid waste apply the protection principle, recovery of resources and remanufacturing.

2) The council should take special procedures to collect , transfer and dispose the following waste, found special places for them, contact the companies that may purchase and reuse them:

1. Construction debris, stones, waste resulting from excavation.
2. Car debris and tires.

3) The council is not obliged to collect, transfer and dispose the following waste:

- a. The hazardous solid waste including the medical waste.
- b. The waste of huge size.

- c. Any other waste the council sees that it should not enter the site.
- 4) The council is not responsible to sweep the streets or clean the public areas, the public storage areas, since these activities remains under the responsibility of the local governments.

**The Council's mission statement**

Providing organized and effective solid waste services, at the regional level (such services must be of good quality, have price tag, protect the public health and the environment), seek-self management and long-term sustainability of services by building the scientific and technical capacities of local governments, raise public awareness and promote effective public participation in this field, comply with pertinent laws and regulations prevailing in Palestine.



## Appendix-C

### Assessment Trip

#### Jenin, May 2008

In May 2008, a team from University of an najah Student traveled to Zahret al fingan land fill to assess problems with solid waste management in Jenin city in the north region of the West Bank.

The goal of this theses is to produce energy from organic solid waste

The primary objectives are to:

- 1) Provide achievable technologies and methodologies designed to improve the solid waste management system.
- 2) Work with residents to implement solid waste management programs.
- 3) Educate the community about the benefits of waste management system.

The poor economy in West Bank results in high unemployment and furthers the need to address issues related to public health.

With the assistance of the local leaders, residents, and expatriate development workers, four key solid waste management must be issues, collection, waste separation, land filling ,Funding for implementation of solid waste management projects and their management is the primary economic issue.

Optimization of the collection process, improving collection capacity, and the provision of additional waste collection bins will serve to improve the collection of the waste.

Since the amount of organic material is such a high percent of the waste stream of West Bank, separating and composting organic wastes from other wastes may be good tool for reducing the overall volume requiring land filling. The organic material can be reduced through anaerobic digestion and would generate quality fertilizer and biogas.

جامعة النجاح الوطنية  
كلية الدراسات العليا

تصميم وبناء هاضم حيوي لانتاج الغاز من النفايات الصلبة

إعداد  
منصور علي السعدي

إشراف  
أ. د. مروان محمود

قدمت هذه الأطروحة استكمالاً لمتطلبات الحصول على درجة الماجستير في هندسة الطاقة  
النظيفة وترشيد الاستهلاك من كلية الدراسات العليا في جامعة النجاح الوطنية في نابلس -  
فلسطين.

2010

ب

## تصميم وبناء هاضم حيوي لانتاج الغاز من النفايات الصلبة

اعداد

منصور علي سليمان السعدي

اشراف

أ. د. مروان محمود

### الملخص

إن هذه الأطروحة تختلف عن غيرها حيث انها تبحث في انتاج غاز الميثان من نفايات المنازل والنفايات العضوية وان امكانيه انتاج الغاز الحيوي في فلسطين كبيرة, ويمكن تعميم فكرة بناء مخمرات منازل من اجل انتاج 24 كغم غاز حيوي شهريا وذلك يعادل 12 كغم من غاز بيوتان, حيث ان القيمة الحرارية للغاز الحيوي تساوي نصف القيمة الحرارية لغاز البيوتان وقد تم دراسة استخدام نفايات المنازل واوراق شجر الحدائق من اجل انتاج غاز الميثان .  
تم تطبيق بعض التجارب العملية لانتاج غاز حيوي في الاراضي الفلسطينية تحت ظروف مناسبة مثل درجة الحرارة = 35 درجة مئوية , درجة الحموضة = 6 - 7 , ومدة انتاج الغاز الحيوي تتطلب من 10 - 60 يوم.

وقد اثبتت الدراسات العملية انه بالامكان تصميم هاضم حيوي بسعة 500 لتر بحيث يتم تغذية ب 400 لتر مخلوط , ماء+نفايات بنسبة 1 : 1 وهذا سيكون كافي لانتاج ما يعادل جرة غاز واحدة من غاز المنازل ( 24 كيلو غرام من غاز الميثان تعادل 12 كيلوا غرام من غاز البيوتان).

ومن هنا تم اقراح تطبيق هاضم حيوي عائلي التغذية اليومية, هذا النظام العائلي سيوفر 840 شيكل سنويا وسيتم استرجاع راس المال المدفوع خلال مدة اقل من سنتين.