

1 Classification of Computer Networks

There are many different network architectures and protocols, each has its own characteristics and application domain. Generally speaking, the networks can be classified into different types according to its transmission technology and its scope.

1.1 Scope of the Networks

One criterion for classifying networks is their scales. According to the network's physical size, the networks can be:

- Personal Area Networks(PAN)

PAN is for one person. A typical example of PAN is wireless communication network. A key capability of PAN is to enable devices to autonomously detect and acquire one another. Other PAN applications include mobile commerce in which user of a mobile device communicates with another machine for commerce such as ticket purchase.

- Local Area Networks(LAN)

LANs are small size networks which only cover a few buildings or a campus of up to a few kilometers. LANs are widely used to connect personal computers and workstations in company offices, factories and universities to share resources and exchange information. Typical example of LAN is to share printers in a Lab or a department.

- Metropolitan Area Networks(MAN)

The size of a MAN can cover a city whose scope is less than 100km. The best-known example of MAN is cable television networks, such as Rogers cableTV systems. High speed wireless Internet access is another MAN.

- Wide Area Networks(WAN)

WANs span large geographical areas, often countries or continents. They contain millions of machines which are connected by communication subnets. Internet is the largest WAN ever established.

1.2 Computer Network Services

The Internet provides two kinds of services to its distributed applications: a *connection-oriented service* and a *connectionless service*.

1.2.1 Connection-Oriented Service

In *connection-oriented network*, a single path is first established for each new connection, which guarantees that data transmitted from the sender to the receiver will eventually be delivered in

order and in its entirety. The advantage of connection-oriented network is that it can provide *reliable data transfer, flow control, and congestion control*.

One important procedure in connection-oriented network is called *handshaking*, where the sender and the receiver send control information to each other before sending real data. Only after handshaking procedure is finished, can a connection be established between two end systems.

A typical example of connection-oriented network is old telephone system, where the operator set up a connection between the caller and the receiver. Once the connection was established, the conversation could be continuing for a long time.

1.2.2 Connectionless Service

In *connectionless network* there is no handshaking procedure. When an end system wants to send information to other end system, it simply sends out the data. Since there is no handshaking procedure prior to the transmission of data, data can be delivered faster.

In connectionless service, every packet of information must have an address. Each packet is routed to its destination by looking at its address. It is similar to the postal system, where a letter is sent to its receiver according to the receiver's mailing address.

1.3 Transmission Technology

Another criterion to classify computer networks is transmission technologies adopted in the networks. Broadly speaking, there are two types of transmission technology that are widespread used, they are:

- Shared-Media-Broadcast links

In *Broadcast Networks*, all end systems share a common channel, that is, a single communication link is shared by all the machines on that network. When a message is transmitted, it can be received and processed by every machine on the network. This mode of operation is called *Broadcasting*. In order to let a host knows whether it is the intended receiver, there is an address field within the message specifying the intended recipient. Upon receiving a message, a host checks the address field, if the message is for the receiving machine, that machine processes the message, otherwise it just ignores the message.

Typical examples of Shared-Media-Broadcast networks include CPU-BUS, Ethernet and Wireless Local Network, two popular topologies of broadcast LAN are *Bus* and *Ring*. Advantages and disadvantages of this architecture are as follows:

Advantages:

- The network is easy to build: in each broadcast network, only one channel needs to be constructed.
- Cost of construction is cheaper compared with other networks.

Disadvantages:

- This architecture is not very scalable and flexible. For example, in a broadcast LAN with Bus topology, at any instant only one machine is allowed to transmit data to other machines. When there are too many machines on a network, sometimes a machine must

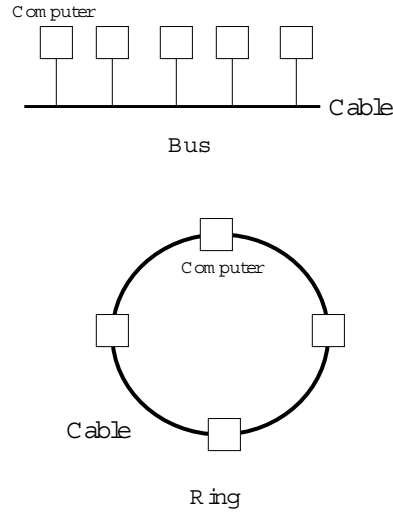

Figure 1: Shared Media Broadcast Network

wait long time before it can transmit data. In this architecture, arbitration mechanism is needed to resolve conflicts when there are two or more machines want to transmit data simultaneously.

- Switched Point-to-Point links

Point-to-Point networks consist of many connections between individual pair of nodes. To go from source to a destination, information travels over several nodes from one host to another host. That is, a packet must have to first visit one or more intermediate machines. Often multiple routes of different lengths are possible. So finding good ones is important in point-to-point networks. Point-to-point transmission with one sender and one receiver is sometimes called *unicasting*.

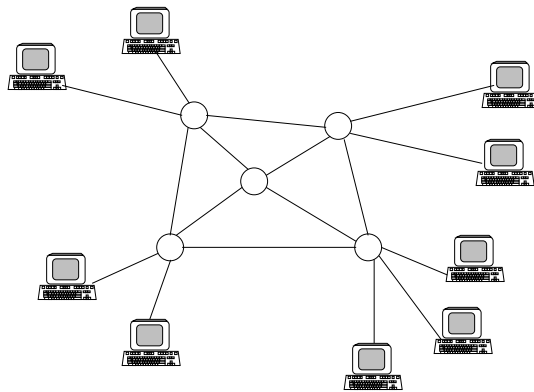

Figure 2: Point-to-Point Networks

Internet is representative of point-to-point network. Scalability is the biggest advantage of this kind of network, since a large point-to-point network can contain many subnets with a smaller collection of machines. But since it needs lots of transmission lines and switching elements (router, switches) to connect remote hosts, this architecture is expensive to build.

2 Point-to-Point Networks

There are two fundamental approaches to build a point-to-point network: *circuit switching* and *packet switching*, corresponding networks are called *circuit-switched networks* and *packet-switched networks*.

In *circuit-switched networks*, a dedicated path is established between end systems in advance, and the resources needed along the path to provide for communication are reserved for the duration of the session. In *packet-switched networks*, these resources are not reserved, a session's message use the resources on demand, so sometimes may have to wait for access to a communication link.

2.1 Circuited-Switched Networks

In *circuit-switched networks*, dedicated path is created between two nodes, and a (dedicated) share of the network capacity is allocated to each session (connection). The steps to transmit data in this network are as follows:

- A circuit is established, an end-to-end connection must exist to transfer data.
- The actual data transfer.
- After data transmitted, connection is terminated.

Representative of circuit-switched network is Telephone network. Before one person can send information (voice or facsimile) to another over a telephone network, the telephone network must establish a connection between two persons, which is called a circuit. After the circuit is established, it reserves a constant transmission rate in the network link for the duration of the connection. This allows the sender to transfer data to receiver at guaranteed constant rate. So this network has advantageous of continuous data transmission and congestion control, therefore, *Quality of Service* is guaranteed.

Disadvantages:

- Uneconomical use of bandwidth due to idle time especially for data.
- Requires same protocol and speed of transmission.
- Relatively inefficient for data transmission.
- Entire channel capacity and sending and receiving machines are dedicated to that call for duration of connection (waste resources).

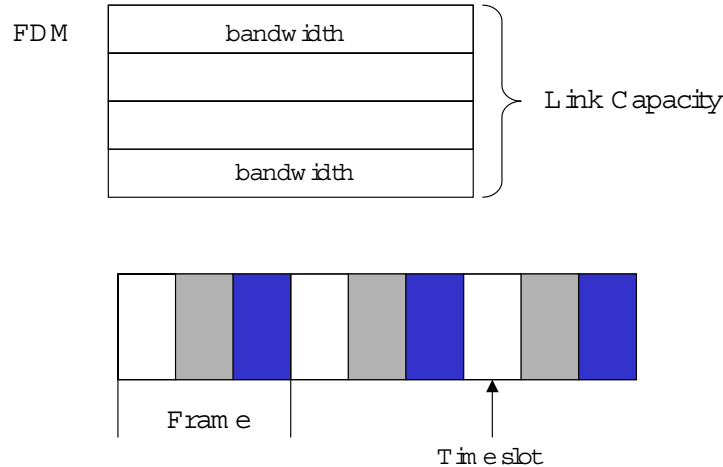

Figure 3: FDM and TDM

2.1.1 Multiplexing—FDM and TDM

There are two modes a circuit in a communication link can be implemented: *frequency-division multiplexing* (FDM) or *time-division multiplexing* (TDM).

In FDM mode, the frequency spectrum of a link is shared by multiple connections established on the link. The link assigns a frequency band to each connection for the duration of the session. The width of the band is called *bandwidth*.

In TDM mode, time is divided into *frames* of fixed duration, and each frame is divided into a fixed number of *time slots*. When a connection is established across a link, one time slot in every frame is dedicated to the connection, the time slots can not be shared with other connections. End systems of the connection can only transmit data during the time slots assigned to its connection.

2.2 Packet-Switched Networks

2.2.1 Characteristics

In *packet-switched network*, messages are broken into small packets. Each of these packets must traverse communication links and packet switches between source and destination. There are multiple buffers (also called queues) within each switch, and each link has an input buffer and an output buffer. Packets from different sources share these network resources.

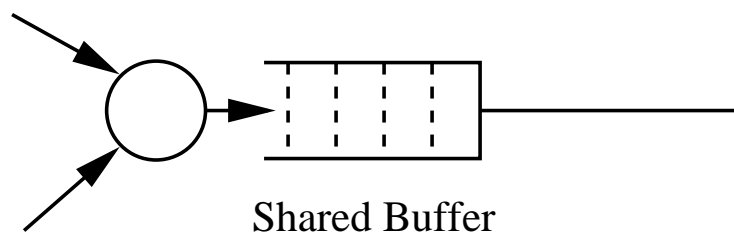

Figure 4: Packet-Switched Network

Internet is an example of packet-switched network. Compared to circuit-switched network, packet-switched network has advantages of efficient use of network resources, that is, there is no capacity waste.

- Buffer and Queue Delay

In packet switching architecture, most packet switches use store-and-forward mode to transmit data, that is, the router must receive the entire packet into its buffer before it begins to transmit the first bit of packet onto its outbound link. Packets are stored in the buffers in the order of their arrival at the routers. With the use of buffers, end devices can send or receive data at their own speed.

In packet-switched network, packets are stored in the buffer before link is available to transmit them. So the buffers play key roles in packet switching process. Compared to circuit switching technique, using of buffer may bring some disadvantages:

- Additional Queue Delay

When link is busy with transmission other packets, the arriving packet must wait in output buffer, suffering output buffer queuing delay. These delays are variable and depend on the level of congestion in the network and capacity of the link.

- Packet Loss

When there is serious network congestion, or link capacity can not match packet arrival rate, new arriving packets will fill buffer space quickly. In this case, when a new packet arrives, packet loss will occur, the arriving packet or one of queued packets will be dropped.

- Statistical Multiplexing

Since there is no fixed connection established between source and destination in packet-switched network, communication links between source and destination are often shared by more than one packets streams from different sources. It often happens that sequence of different packet streams do not follow any period ordering, that is, the ordering of packets form each source is random or statistical because packets are sent whenever they happen to be present at the link. In this case, packet switching employs *statistical multiplexing*.

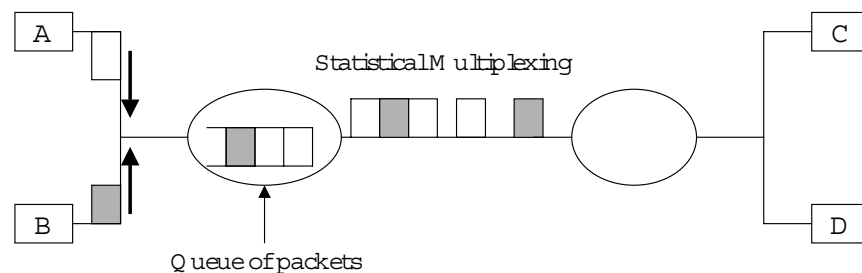

Figure 5: Statistical Multiplexing Network

There are two classes of packet-switched networks: *Datagram Networks* (Connectionless) and *Virtual Circuit Networks* (Connection-Oriented).

2.2.2 Connection-Oriented Packet-Switched Networks

In this architecture, virtual path (virtual circuit – VC) that consists of a series of links and switches needs to be established between the source and destination hosts before data transmission. After path is built, all packets generated by a session follow the same path. So this network could provide services for those network applications that requires sequential packet delivery. Representative of this architecture is ATM (Asynchronous Transfer Mode) which can transmit data, voice.

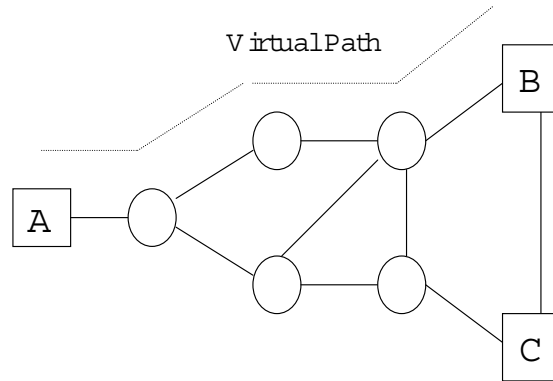

Figure 6: Virtual Circuit Network

- VC-number and state information

In virtual circuit network, besides established path between source and destination, the network utilizes virtual circuit number (VC-number) and VC-number translation table to decide how to route the packets. After a VC is established, packets can be sent with appropriate VC numbers, a VC has a different VC-number on each link, an intermediate switch replaces the VC-number for each packet with a new one when the packet passes through the switch.

In VC network, the switches must maintain *state information* for each ongoing connection (or session). Each time a new connection is established across the switch, a new entry is added to the VC-number translation table and when a connection is released, corresponding entry must be removed from the table.

- Advantages

Although in virtual circuit network, the switches could become overloaded because of managing too many connections, and network can be overly complex, it still has lots of advantages, as shown as follows:

Advantages:

- Keep packets order, that is, the packets arrive at receiver with the same order being sent.
- Since all packets follows a specific path, it improves information security.
- Switch faster. Once a connection is established, each switch can "remember" its state information.
- Easy to manage. It is possible to calculate round-trip delay.

2.2.3 Connectionless Packet-Switched Networks

This architecture is also called *Datagram Network*. In Datagram Network, packets of a session can follow different paths, that is, each packet is independently transmitted and routed. Similar to postal service, in this architecture, each packet includes the destination address in its header. When a packet arrives at a switch, the switch examines the packet's destination address, and forwards it to the adjacent switch. This process repeats until the packet arrives the receiver.

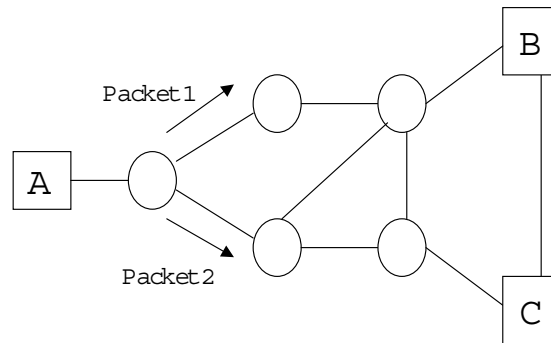

Figure 7: Connectionless Packet-Switched Network

The only advantage of this architecture is its flexibility, since a switch can choose different path for each packet based on the network condition. An example of this architecture is *Internet*. However, this architecture has drawbacks of switching slower due to not maintaining connection's state information in their switches, packets arriving of wrong order, hard to predicate delay, so the *Quality of Service* can not be guaranteed.

3 Typical Network

From above discussion we can see that each architecture has its own advantages and disadvantages, each has its own application domain. For example, digitized voice transmission requires that the network has fixed small delay, and must provide moderate reliability. So circuit-switched network is best choice. For long distance file transfer, users can tolerate moderate delay, but at the same time, demand high reliability, so connectionless packet-switched network is a good choice because it can provides efficient use of network bandwidth.

In fact, Wide Area Network architecture is more complicated, it often consists of many Local Area Networks with different network architectures, just as shown in the following figure. Therefore, understand mechanism of each architecture will benefit us to understand and design complicated computer networks.

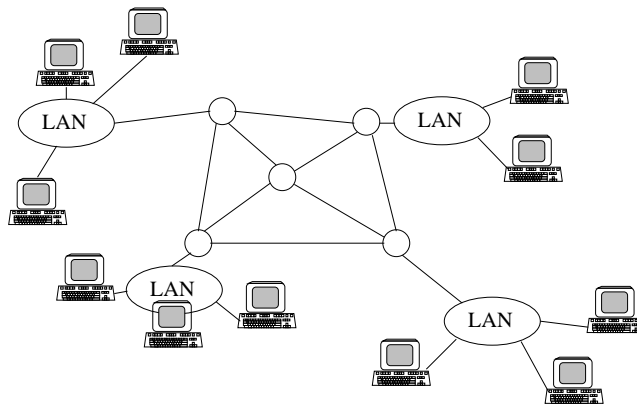

Figure 8: Wide Area Network